

# Electrical Equivalent Analysis of Micro Cantilever Beams for Sensing Applications

B. G. Sheeparamatti, J. S. Kadadevarmath

**Abstract**—Microcantilevers are the basic MEMS devices, which can be used as sensors, actuators and electronics can be easily built into them. The detection principle of microcantilever sensors is based on the measurement of change in cantilever deflection or change in its resonance frequency. The objective of this work is to explore the analogies between mechanical and electrical equivalent of microcantilever beams. Normally scientists and engineers working in MEMS use expensive software like CoventorWare, IntelliSuite, ANSYS/Multiphysics etc. This paper indicates the need of developing electrical equivalent of the MEMS structure and with that, one can have a better insight on important parameters, and their interrelation of the MEMS structure. In this work, considering the mechanical model of microcantilever, equivalent electrical circuit is drawn and using force-voltage analogy, it is analyzed with circuit simulation software. By doing so, one can gain access to powerful set of intellectual tools that have been developed for understanding electrical circuits. Later the analysis is performed using ANSYS/Multiphysics - software based on finite element method (FEM). It is observed that both mechanical and electrical domain results for a rectangular microcantilevers are in agreement with each other.

**Keywords**—Electrical equivalent circuit analogy, FEM analysis, micro cantilevers, micro sensors.

## I. INTRODUCTION

**M**ICROCANTILEVER is the basic microstructure used in most of MEMS structures such as sensors and actuators [1]. A sensor receives a stimulus and responds with a signal, and an actuator responds by producing a motion or change in the system. When a microstructure is modeled, two important factors have to be considered, one being effects of scaling and the other one is material properties of the material used [2]. One can model, simulate, analyze and fabricate a rectangular microcantilever. Many microcantilever based sensors have been designed, analyzed and fabricated in the past [3].

For the cantilever which is nothing but a beam supported at only one end, the basic beam equations are (1) and (2). The spring constant  $k$  is the proportionality factor between applied force  $F$ , and the resulting bending of the cantilever is  $z$ .

For point load (Elementary theory of beams) [4]

$$z \text{ (Deflection)} = \frac{FL^3}{3EI} \quad (1)$$

where,

$$I = \frac{wt^3}{12}$$

B. G. Sheeparamatti is with the Department of E&CE, Basaveshwar Engineering College, Bagalkot, Karnataka, India (e-mail: sheepar@yahoo.com).

Therefore,

$$z = \frac{4FL^3}{Ewt^3} \quad (2)$$

The spring constant is related to the cantilever resonance frequency by the conventional harmonic oscillator formula (3). A microcantilever may only vibrate in bending and therefore can be modeled as a single-degree-of-freedom member by means of lumped-parameter properties. For a single-degree-of-freedom formed of a body of mass  $m$ , spring of stiffness  $k$ , and a dashpot  $c$ , the dynamic equation is

$$\omega_0 = \sqrt{\frac{k}{m^*}} \quad \text{or} \quad f = \frac{1}{2\pi} \sqrt{\frac{k}{m^*}} \quad (3)$$

The first modal frequency of a rectangular cantilever beam is (4):

$$\omega_1 = \frac{3.52}{L^2} \sqrt{\frac{EI}{\rho A}} \quad (4)$$

## II. THEORETICAL BACKGROUND

### A. Electrical Equivalent Circuit Analysis

A representative linear model of the micro cantilever is built for easy analysis and design of micro cantilever based systems. The simplest model is the single degree of freedom lumped mass model defined by second order differential equation with constant coefficients. Using fundamental mechanical elements like mass, spring, and dashpot a simple linear mechanical model of micro cantilever is built and is shown in Fig. 1. In this case, single degree of freedom is considered for simplicity.

The equation of motion for the single degree of freedom system, the microcantilever, is shown in Fig. 1 and (5).

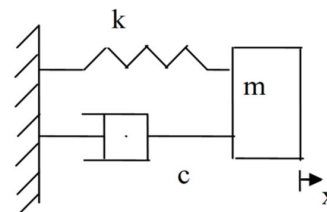

Fig. 1 Simplified mechanical model of the Microcantilever

$$m \frac{d^2x}{dt^2} + c \frac{dx}{dt} + kx = F \quad (5)$$

where, F can be either D.C. or A.C. signal, m is the mass, c is the damping and k is the stiffness with the displacement, velocity and acceleration and forcing function as shown.

The system shown above is analogous to a series RLC circuit. Fig. 2 shows a series RLC circuit which is the equivalent circuit of the micro cantilever in electrical domain. By doing so, one can gain access to powerful set of intellectual tools that have been developed for understanding electrical circuits. These types of analogies also permit efficient modeling of the interaction between the electrical and the non-electrical components of a micro system. A further advantage of circuit models is that, they are intrinsically correct from energy point of view. Thus, they represent explicit representation for power and energy, and hence energy exchange of transducers can be captured. Two systems are analogous when they can be described by similar mathematical models [5].

It can be seen that (5) describes the forced motion of micro cantilever's equivalent mechanical model. Equation 6 describes the behavior of micro cantilever beam in electrical domain. Both are second-order differential equations with constant coefficients, and hence the two systems can be considered as analogous. This type of electrical analogy is called force-voltage (or mass-inductance) analogy.

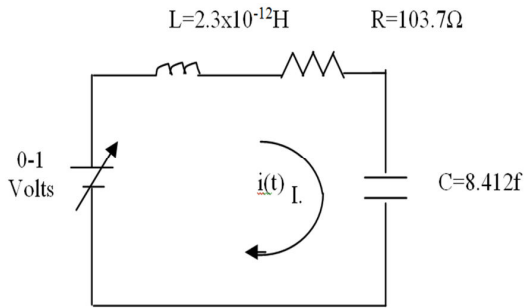

Fig. 2 Simplified electrical equivalent model of the microcantilever

$$L \frac{d^2q}{dt^2} + R \frac{dq}{dt} + \frac{1}{C} = V \tag{6}$$

Similarly using fundamental mechanical elements simple linear mechanical model of microcantilever with added mass m2 is built and shown in Fig. 3. The added mass indicates. In this case, single degree of freedom is considered for simplicity.

The equation of motion for the single degree of freedom system – the micro cantilever which is shown in Fig. 3 is referred to (7).

$$(m1 + m2) \frac{d^2x}{dt^2} + c \frac{dx}{dt} + kx = F \tag{7}$$

where, F can be either D.C. or A.C. signal.

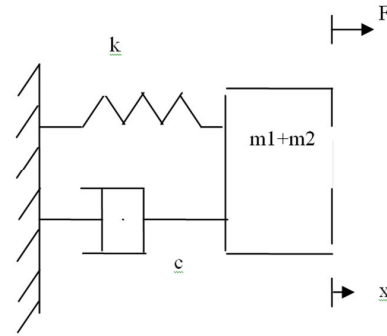

Fig. 3 Simplified mechanical model of the Micro cantilever

The system shown above is analogous to a series RLC circuit. Fig. 4 shows a series RLC circuit which is the equivalent circuit of the micro cantilever in electrical domain. Two systems are analogous when they can be described by similar mathematical models [5].

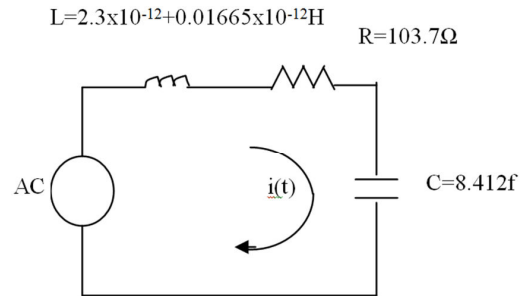

Fig. 4 Simplified electrical equivalent model of the micro cantilever

$$(L_1 + L_2) \frac{d^2q}{dt^2} + R \frac{dq}{dt} + \frac{1}{C} = V \tag{8}$$

It can be seen that (7) describes the forced motion of micro cantilever's equivalent mechanical model and (8) describes the behavior of micro cantilever beam in electrical domain. Both are second-order differential equations with constant coefficients, and hence the two systems can be considered as analogous. This type of electrical analogy is called force-voltage (or mass-inductance) analogy.

The resonance frequency  $f_r$  of the analogous electrical system is obtained by Bode plot of its transfer function H(s) using MATLAB. Fig. 5 shows the Bode plot of electrical equivalent RLC circuit of Fig. 2. The resonance frequency  $f_r$  of the analogous electrical system is obtained by Bode plot of its transfer function H(s) using MATLAB. Fig. 6 shows the Bode plot of electrical equivalent RLC circuit of Fig. 4.

The transfer function can be obtained from this circuit (Fig. 2) by taking output across 'c'.

Transfer Function;

$$\frac{V_o(s)}{V_i(s)} = \frac{\frac{1}{LC}}{s^2 + \frac{R}{L}s + \frac{1}{LC}} = \frac{5.163 \times 10^{10}}{s^2 + 5.6913 \times 10^{11} s + 5.163 \times 10^{10}}$$

This value of transfer function can be used to find the system response of the micro cantilever and the impulse, step responses and pole-zero plots of the micro cantilever are obtained. The impulse response of RLC equivalent cantilever is bounded and causal; hence, the system produces finite output for any finite input. And, the system is realizable. The step response of RLC equivalent micro cantilever is having steady error  $e_{ss}(t)=0$ . The system is over damped ( $\xi > 1$ ) and rise time = 28 Sec. From the pole-zero plot it is observed that the poles are present in left half of s-plane which indicates stable operation of the system and obeys bounded input bounded output condition.

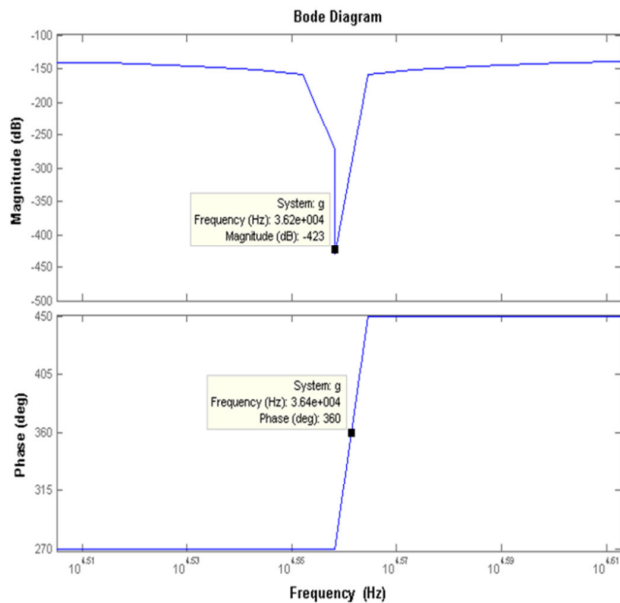

Fig. 5 Bode plot for the electrical model of the microcantilever

III. FEM IMPLEMENTATION

FEM is a widely used analysis and design technique, and this can be easily visualized by ANSYS software: ANSYS/Multiphysics helps in multi domain analysis like MEMS modeling and simulation. As all the dimensions are taken in microns, Young’s modulus, resistivity, and thermal conductivity are also taken in  $\mu$ MKS units. The static and modal analysis of micro cantilever beam is carried out using ANSYS-8. Stress and deflection of the micro cantilever are the results obtained by static analysis while natural frequency or resonance frequency is obtained by dynamic analysis.

One can visualize the results of simulation in post-processing option of the software. The deformed shape of Fig. 7 has different color contours. Each color contour indicates the value of stress experienced at different points on the beam and a scale for those colors is shown at the bottom. Numerical values for maximum deflection are displayed at the top left corner of the screen. By choosing appropriate option in ANSYS, the beam before deformation can also be displayed so that the difference in position can be better observed. Fig. 7 shows the ANSYS output after applying some input

deformation contours. Fig. 8 shows the ANSYS output for 1<sup>st</sup> modal frequency. Fig. 9 shows the ANSYS output of change in resonance frequency for added mass.

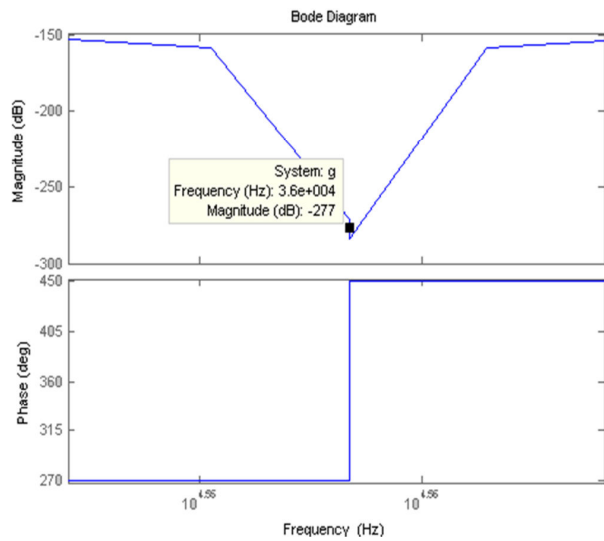

Fig. 6 Bode plot for the electrical model of the microcantilever

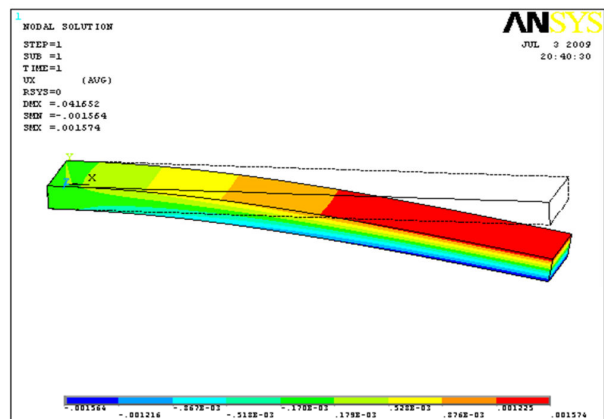

Fig. 7 Cantilever representing the deformation contours

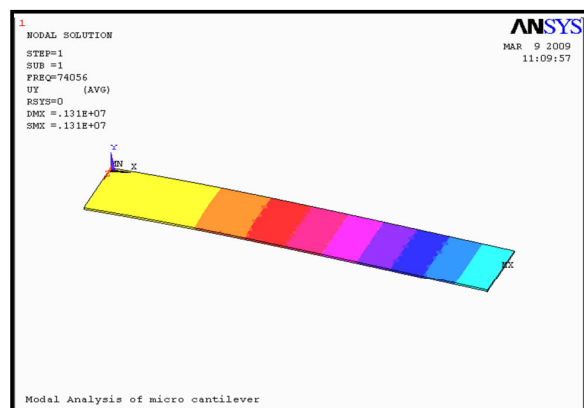

Fig. 8 Vibrating Cantilever in mode-1 with deformation contours

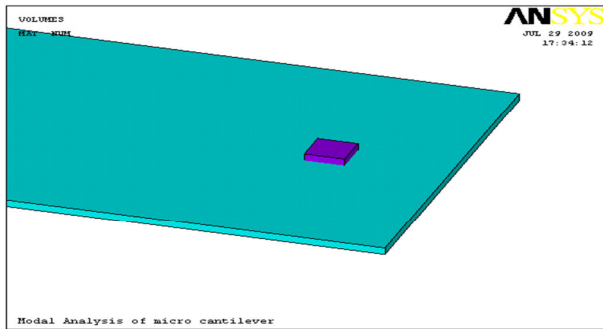

Fig. 9 Cantilever with added mass

TABLE I  
ANALYTICAL, ELECTRICAL CIRCUIT SIMULATION AND ANSYS SIMULATION  
DEFLECTIONS

Sl. No.	Force( $\mu$ N) or Volts ( $\mu$ V)	Deflection (Analytical) ( $\mu$ m)	Electrical Equivalent Network simulation			ANSYS ( $\mu$ m)
			C (Farads)	Vc ( $\mu$ V)	Q (Charge Stored)	
0.1	0.1	0.84211	8.421	0.1	0.8421	0.82866
02	0.2	1.68421	8.421	0.2	1.6842	1.657
03	0.3	2.52632	8.421	0.3	2.5263	2.486
04	0.4	3.36842	8-421	0.4	3.3684	3.315
05	0.5	4.21053	8.421	0.5	4.2105	4.143
06	0.6	5.05263	8.421	0.6	5.0526	4.972
07	0.7	5.89474	8.421	0.7	5.8947	5.801
08	0.8	6.73684	8.421	0.8	6.7368	6.629

TABLE II  
ANALYTICAL, ELECTRICAL CIRCUIT SIMULATION ANANSYS SIMULATED<sup>1st</sup>  
MODAL FREQUENCIES

Sl. No.	Cantilever of 100x20x0.5 ( $\mu$ m)	Analytical 1 <sup>st</sup> Modal Frequency (Hz)	Electrical equivalent 1 <sup>st</sup> Modal Frequency (Hz)	ANSYS Simulated 1 <sup>st</sup> Modal Frequency (Hz)
1	without added mass	72,990	73, 558 Hz	73,743
2	with added mass	72,560	72,000 Hz	73,040

#### IV. RESULTS

The simulated results of above equivalent RLC circuit are obtained using circuit simulation software. The voltage across capacitor C and the charge stored in the capacitor are tabulated in Table I. It is observed that deflection in mechanical system and charge stored in electrical system (capacitor) are same. However using the expression for resonance frequency of microcantilever, the resonance frequency is found to be almost same as that of electrical stimulation. It is observed that the resonance frequency of electrical network is found same as simulated frequency (73, 558 Hz). Thus, it may be concluded that for the uniform rectangular cantilevers the results of electrical equivalent circuit are sufficient enough to find deflection and resonance frequencies. It is observed that the resonance frequency of electrical network is found same as simulated frequency (72,000 Hz). Thus, it may be concluded that for the uniform rectangular cantilevers the results of electrical equivalent circuit are sufficient enough to find deflection and resonance frequencies.

#### V. CONCLUSIONS

In this work, analogies between mechanical and electrical systems have been explored with respect to micro cantilevers. ANSYS/Multiphysics which is used in modeling and simulation of microstructures has been used to validate the results of equivalent electrical circuit. On this electrical equivalent, multiple energy domains like electrical, electrostatic, electromagnetic and other forces can be applied and their effect can be studied. This can lead to exploit the full potential of micro cantilevers in micro-electro-mechanical systems. These results show that, electrical equivalent circuit analysis can be used for modeling rectangular micro cantilevers. Such modeling, simulation, and analysis can help in reducing product design cycle time and time to market. This confirms the equality of results in both mechanical and electrical domains.

#### REFERENCES

- [1] M. J. Sepaniak, P. G. Datskos, N. V. Lavrik, C. A. Tripple, "Microcantilever transducers: A new approach in Sensor Technology", *Analytical Chemistry*, 74, 568A (2002).
- [2] Sheeparamatti B. G, Hebbal M. S, Kadadevaramath J. S, "FEM modeling of MEMS based sensor for sensing Antibody/Antigen" Proceedings of International Conference on materials, structures and systems organized by Institute of Smart Structures and Systems(ISSS), IISc Bangalore July 28-30, 2005
- [3] Sheeparamatti B. G, Hebbal M. S, Rajeshwari Sheeparamatti, Math V.B, Kadadevaramath J. S, "Simulation of Biosensor using FEM", proceedings of the International Conference on MEMS (IMEMS-06), NTU Singapore 9 to 12 May 2006
- [4] Warren C. Young, *Roark's Formulas for Stress and Strain*, McGraw-Hill, New York, 1989.
- [5] Ogata K, "*Modern Control Engineering*", Prentice-Hall, Englewood cliffs, N. J.1990.