

# Effect of Transverse Reinforcement on the Behavior of Tension Lap Splice in High-Strength Reinforced Concrete Beams

Ahmed H. Abdel-Kareem, Hala. Abousafa, Omia S. El-Hadidi

**Abstract**—The results of an experimental program conducted on seventeen simply supported concrete beams to study the effect of transverse reinforcement on the behavior of lap splice of steel reinforcement in tension zones in high strength concrete beams, are presented. The parameters included in the experimental program were the concrete compressive strength, the lap splice length, the amount of transverse reinforcement provided within the splice region, and the shape of transverse reinforcement around spliced bars. The experimental results showed that the displacement ductility increased and the mode of failure changed from splitting bond failure to flexural failure when the amount of transverse reinforcement in splice region increased, and the compressive strength increased up to 100 MPa. The presence of transverse reinforcement around spliced bars had pronounced effect on increasing the ultimate load, the ultimate deflection, and the displacement ductility. The prediction of maximum steel stresses for spliced bars using ACI 318-05 building code was compared with the experimental results. The comparison showed that the effect of transverse reinforcement around spliced bars has to be considered into the design equations for lap splice length in high strength concrete beams.

**Keywords**—Ductility, high strength concrete, tension lap splice, transverse reinforcement, steel stresses.

## I. INTRODUCTION

ADEQUATE bond between concrete and reinforcing bars in a splice is an essential requirement in the design of reinforced concrete structures. Most design codes specify minimum length of the lap splice as well as the required transverse reinforcement. According to ACI 318-05 [1], stirrups area in excess of the required for shear and torsion is provided along each terminated bar or wire over a distance (3/4) the effective depth of member from terminal point, without specify a special shape of stirrups required in splice zone. Diab [2] tested twelve normal strength concrete beam specimens. In this study, the type, spacing and shape of transverse reinforcement in splice region among other variables were considered. He concluded that there is a drastic increase in ductility of beams when transverse reinforcement was used.

Concrete properties have a significant effect on the bond strength between reinforcing bars and concrete. Many researchers studied the behavior of tension lap splice in

normal strength and high strength reinforced concrete beams [3]-[8]. Azizinamini et al. [9], [10] studied the effect of high strength concrete on bond using beam splice tests. They noted that the bearing capacity of concrete increased (related to  $f_c'$ ) more rapidly than tensile strength (related to  $\sqrt{f_c'}$ ) as compressive strength increases. For high-strength concrete, the higher bearing capacity prevents crushing of the concrete in front of the bar ribs, which reduces local slip. They concluded that, because of the reduced slip, fewer ribs transfer load between the steel and the concrete, which increases the local tensile stresses and initiates a splitting failure in the concrete prior to achieving a uniform distribution of the bond force. Because of the brittle nature of this failure, they recommended that a minimum quantity of stirrups be used for bars spliced in high strength concrete.

The main object of the research program reported in this paper is to study the effect of the transverse reinforcement on strength, mode of failure and displacement ductility of tension lap splice anchored in high strength concrete beam with concrete compressive strength ranging from 60 to 100 MPa. To meet the objective, seventeen high strength concrete beam specimens were tested. Each beam was designed with bars spliced in a constant moment region at mid-span. The variables used in the investigation were concrete compressive strength, lap splice length, the amount of vertical transverse reinforcement to be placed in the splice region, and the shape of stirrups around spliced bars. The prediction of maximum steel stresses in spliced bars using ACI Building Code was compared with the experimental results.

## II. EXPERIMENTAL TEST PROGRAM

### A. Test Specimen

Seventeen reinforced concrete beams were tested in positive bending. The loading system was designed to produce a constant moment in the middle of the beam specimen. Reinforcement on the tension side consisted of two 16mm-diameter deformed bars spliced at mid-span. The cross section dimensions of tested beams were 160 x 250 mm, and the concrete cover was constant in all sides of beams and equal to the spliced bar diameter ( $d_b$ ).

The length of beam specimens was 3200mm with a distance of 3000mm between the supports. The distance between the two applied loads was 1000mm. Transverse reinforcement was provided outside splice region of all beams to avoid shear failure. It consisted of 8mm mild steel placed at spacing of

A. H. and H. A. are with the Civil Engineering Department, Benha Faculty of Engineering, Benha University, Egypt (Phone: 002- 01002412546; fax: 13512; e-mail:ahassan\_k64@yahoo.com, hala.abousafa@bhit.bu.edu.eg).

O. E. is with the Civil Engineering Department, Benha Faculty of Engineering, Benha University, Egypt (Phone: 002- 01120777565; fax: 13512; e-mail:human\_ib@yahoo.com).

125mm. Longitudinal and cross section details of the beam specimens are shown in Fig. 1.

The studies parameters are given in Table I and divided to four groups as follow:

#### 1. Concrete Compressive Strength

Six beam specimens were tested with concrete compressive strength ranging from 60 to 100 MPa. Three beams were without transverse reinforcement in the splice zone and the other three beams with transverse reinforcement calculated according to ACI 318-05 for beam specimen with concrete compressive strength 60 MPa (B4).

#### 2. Length of Lap Splice ( $l_s$ )

Three values of the lap splice length were investigated:  $l_s = 420, 320, 210$  mm. The lap splice lengths 420 and 320 mm and the required transverse reinforcement in the splice zone were calculated according to ACI 318-05 for beam specimens with concrete compressive strength 60 MPa (B4) and 100 MPa (B7), respectively. The lap splice length 210 mm was two-thirds that required for beam specimen B7 (B10).

#### 3. Amount of Transverse Reinforcement in the Splice Region

The effect of the amount of transverse reinforcement crossing the potential splitting plane in the splice region was studied by changing the spacing between vertical transverse reinforcement. Three different spacing values were studied:  $s=150, 125, \text{ and } 100$  mm.

#### 4. Shapes of Transverse Reinforcement in the Splice Region

Vertical stirrups with different spacing values were provided in beam specimens B4 - B12, while vertical stirrups with additional legs were used in beam B13. Beam specimens

B14 - B17 included stirrups around spliced bars with different shapes and spacing plus vertical stirrups at 100 mm spacing.

The shapes of stirrups around spliced bars were Rectangular hoops, two interlocking spirals, continuous spiral around each spliced bar, and continuous rectangular stirrups for beams B14, B15, B16, and B17, respectively, as shown in Fig. 2. All transverse reinforcement in the splice zone was 6 mm mild steel.

#### B. Material Properties

Three concrete mixtures were used to study the effect of concrete strength on splice strength. The designed characteristic concrete strengths of the beam specimens were 60, 85, and 100 MPa. To produce such concrete, mineral and chemical admixtures were used plus ordinary Portland cement and fine and coarse aggregate. The fine aggregate was natural sand with a fineness modulus of 2.8. The coarse aggregate was crushed Dolomite with a maximum size 10mm. The mineral admixture was light gray locally produced silica fume. The chemical admixture was super-plasticizer used to adjust the workability. Mixture proportions are shown in Table II.

Typically, three 150 x 150 x 150mm cubes were cast with each test beam and used for compression test. A few hours after casting, the beams and the cubes were covered with wet cotton sheets. Form stripping was done after two days from casting, the beams and the cubes were kept under the same curing conditions. Compression test on cubes were carried out in the same day of beam testing, and the test results are given in Table III.

The yield strength of bottom longitudinal reinforcement and stirrups used in the lap splice region were 440 MPa and 280 MPa for diameter 16 mm and 6 mm, respectively.

TABLE I  
DETAILS OF TEST SPECIEMENS

Beam Specimen	Concrete Compressive Strength (Mpa)	Splice Length (mm)	Transverse Reinforcement in Splice Region		
			Vertical Stirrups	Stirrups around Spliced Bars	
			Spacing (mm)	Pitch (mm)	Shape
B1	60.7	420	—		None
B2	81.2	420	—		None
B3	103.2	420	—		None
B4	58.7	420	150		None
B5	80.7	420	150		None
B6	102.5	420	150		None
B7	104.3	320	150		None
B8	99.6	320	125		None
B9	105.7	320	100		None
B10	108.4	210	150		None
B11	101.6	210	125		None
B12	104.3	210	100		None
B13	102.6	210	100		Vertical stirrups with addition legs
B14	103.7	210	100	100	Rectangular stirrups
B15	105.8	210	100	60	Two interlocking spirals
B16	106.7	210	100	60	Continuous spiral around each spliced bar
B17	104.5	210	100	60	Continuous rectangular stirrups

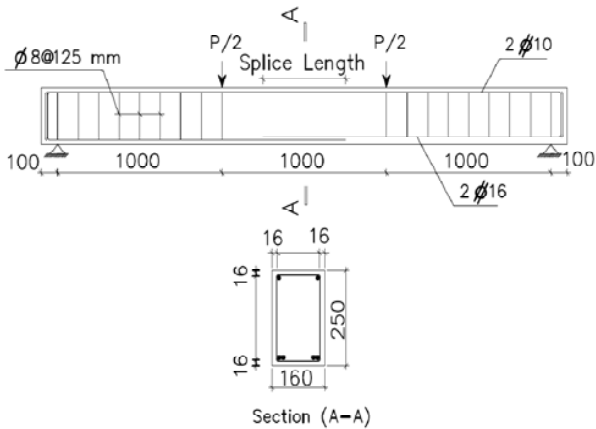

Fig. 1 Longitudinal and cross section details of beam specimens  
(Note: all dimensions are in mm.)

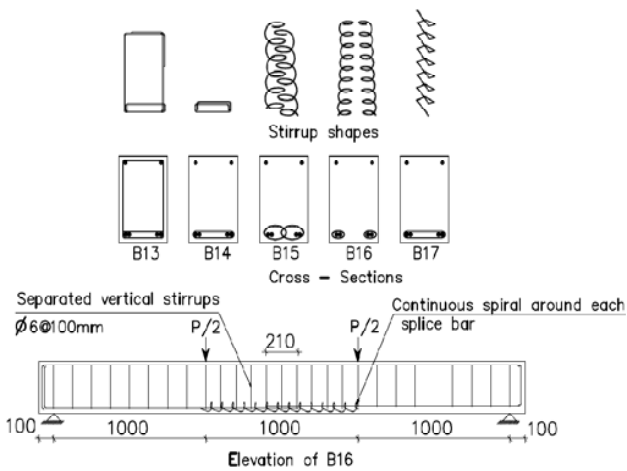

Fig. 2 Details of stirrups around spliced bars

C. Test Setup and Test Procedure

The load was applied through a mechanical screw jack and was transferred to the test beam through a steel spreader beam that was supported on two steel rollers covering the entire width of the beam. The load was measured using electrical load cell under the screw jack of maximum capacity 1000 KN. The deflections were measured by three Linear Variable Displacement Transducers (LVDTs). Two LVDTs were placed under the two load points and the third one was placed under the middle of the beam span. The Load cell and three LVDTs were connected to a data acquisition system to record the data. Figs. 3 and 4 show schematic and photograph of the test setup for splice beam.

Load was applied to the specimens until cracking was observed on the tension side of the beams. While the load was held constant, cracks were traced. Loading continued in this fashion, with pauses after approximately 5 KN increments for crack tracing. Loading was continuous after failure using Screw jack. The output data were recorded by the data acquisition system. Pictures were taken after failure and spalled concrete was used to measure actual cover.

Target $f_c$ (Mpa)	Mix Proportion (KN/m <sup>3</sup> )					Dosage of Super-plasticizer
	Dolomite	Sand	Water	Cement	Silica Fume	
100	12.500	5.00	1.430	4.675	0.825	3.0
85	12.500	5.00	1.650	4.950	0.550	2.0
60	11.600	5.80	1.800	4.500	-	1.0

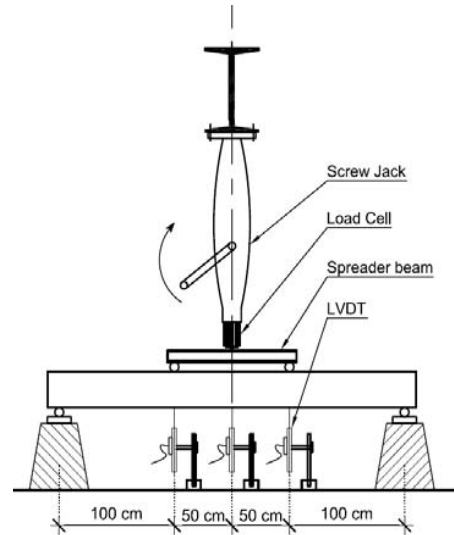

Fig. 3 Schematic of test set-up for splice beam



Fig. 4 Splice beam prior to testing

III. EXPERIMENTAL RESULTS AND DISCUSSION

A brief summary of the test results is given in Table III. The test results will be discussed in the following items:

A. Failure Mode

The first flexural cracks in all beams occurred randomly in the constant moment region on the tension side of the beam outside the splice length, as load increased, cracks formed along the entire length of the constant moment region including the splice region. The failure modes of tested specimens were either splitting bond failure or ductile flexural failure according to the confinement provided by transverse

reinforcement. Beam specimens without confining transverse reinforcement along the splice length failed suddenly after the initiation of the splitting cracks without warning or propagation of the cracks accompanied by loss of the concrete cover over the entire lap splice length as shown in Fig. 5.

The splitting failure of the beam specimens with transverse reinforcement in splice region was more ductile and allowed propagation of the splitting cracks between flexural cracks prior to failure. Presence of transverse reinforcement eliminated propagation and widening of the splitting cracks. The splitting failure for beam specimens with lap splice length less than the required by ACI code not appeared any ductility and the load dropped suddenly after reaching a peak. Fig. 6 shows the typical splitting failure of the beam specimens with transverse reinforcement in splice region.

For the flexural failure, the flexural cracks extended upward to be very close to the top surface of the beam, very narrow longitudinal splitting cracks occurred along the splices, without a splitting failure. The ductile flexural took place by crushing concrete in compression nearly the concentrated load. Fig. 7 shows the typical flexural failure of the beam specimens. A summary of the mode of failure for tested beams is shown in Table III.

Comparing the mode of failure of beam specimens, the failure mode changed from splitting bond failure to ductile flexural failure in these cases:

- 1) Increasing the concrete compressive strength up to 100 Mpa for beam specimen included transverse reinforcement in the splice region (B6).
- 2) Increasing the vertical transverse reinforcement in splice region more than 25% the required by ACI code. (B8, B9).
- 3) Using stirrups around spliced bars in beam specimens with lap splice length two-thirds that required by ACI code (B13-B17). While, the beam specimen with the same splice length and vertical stirrups only sudden failed.

#### B. Load-Deflection Behavior

The relationship between load and mid-span deflection for beam specimens are presented in Figs. 8-11. The flexural stiffness of all tested beams was almost identical below the cracking load. Fig. 8 shows that after cracking, the stiffness of the tested beams increased (less deflection for the same load) as the concrete compressive strength increased. The post cracking stiffness was almost identical for all beam specimens with the same concrete compressive strength, and did not affected by the presence, number and shape of transverse reinforcement. There was a consistent increase in the ultimate load and the deflection as the concrete compressive strength, lap splice length, and number of transverse reinforcement in splice region increased. Providing stirrups around spliced bars, the beam specimens were cable of carrying more load and the deflection significantly increased, especially for beams with two interlocking spirals around spliced bars B15 and continuous spiral around each spliced bar B16. Comparing with beam specimen included vertical transverse reinforcement only in the splice region B12, ultimate load for

B15 and B16 increased by 45% and 41%, respectively, and ultimate deflection for B15 and B16 increased by 366% and 493%, respectively.



Fig. 5 Typical splitting failure for beam specimens without confining transverse reinforcement



Fig. 6 Typical splitting failure for beam specimens with confining transverse reinforcement in splice region



Fig. 7 Typical flexure failure for beam specimens

TABLE III  
SUMMARY OF TEST RESULTS

Beam Specimen	Concrete Compressive Strength (Mpa)	Ultimate Load Pu (KN)	Deflection at Yield Load $\Delta_y$ (mm)	Deflection at Pu $\Delta_u$ (mm)	Deflection at 80% Pu $\Delta_{max}$ (mm)	Mode of Failure	Displacement Ductility ( $\mu$ )	Stresses in Spliced Bars at Failure $f_s$ (Mpa)
B1	60.7	64.0	12.10	12.92	14.20	Splitting	1.17	375.65
B2	81.2	78.5	14.00	21.73	22.50	Splitting	1.61	460.35
B3	103.2	80.8	14.00	18.29	28.00	Splitting	2.00	467.77
B4	58.7	65.1	12.70	13.40	18.50	Splitting	1.46	383.75
B5	80.7	83.6	14.00	28.14	32.80	Splitting	2.34	492.74
B6	102.5	92.3	14.50	47.77	50.40	Flexure	3.48	538.68
B7	104.3	85.1	15.40	38.32	42.00	Splitting	2.73	493.68
B8	99.6	90.9	14.00	41.57	45.95	Flexure	3.28	531.35
B9	105.7	92.8	14.50	43.71	48.20	Flexure	3.32	541.16
B10	108.4	63.9	11.50	11.50	12.20	Splitting	1.06	369.78
B11	101.6	62.2	12.05	10.63	14.00	Splitting	1.16	360.22
B12	104.3	65.7	12.04	12.04	15.80	Splitting	1.31	380.66
B13	102.6	84.3	14.90	34.39	41.00	Flexure	2.75	489.30
B14	103.7	83.7	15.00	38.68	44.50	Flexure	2.97	485.32
B15	105.8	94.3	15.00	55.76	72.00	Flexure	4.80	550.24
B16	106.7	92.7	16.00	56.53	103.50	Flexure	6.47	539.60
B17	104.5	85.3	15.20	40.67	44.70	Flexure	2.94	494.85

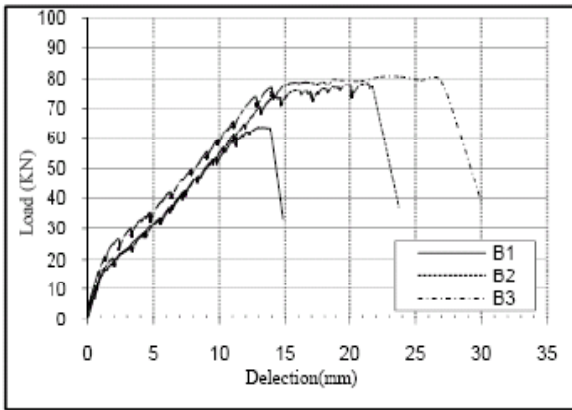

(a) Without stirrups

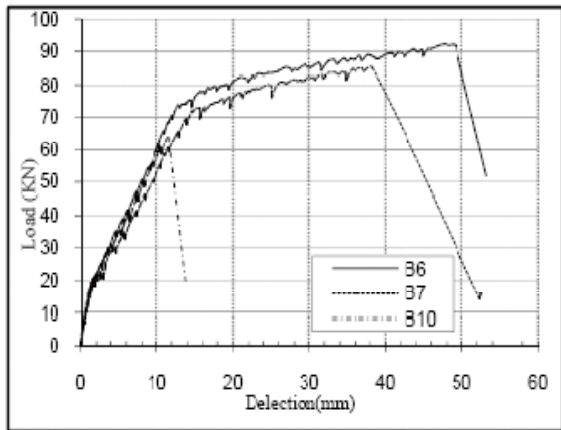
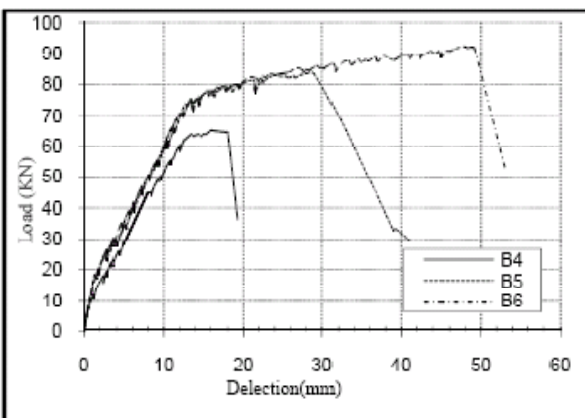

Fig. 9 Load-deflection curves for beam specimens with different lap splice length (vertical stirrups at 150 mm spacing in splice region)



(b) With vertical stirrups

Fig. 8 Load-deflection curves for beam specimens with different concrete compressive strength

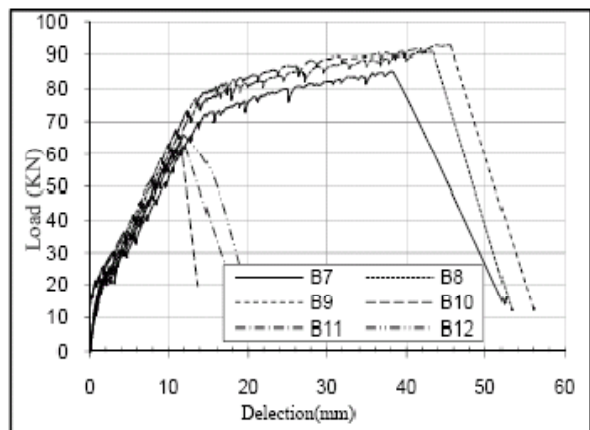

Fig. 10 Load-deflection curves for beam specimens with different vertical stirrups spacing in splice region

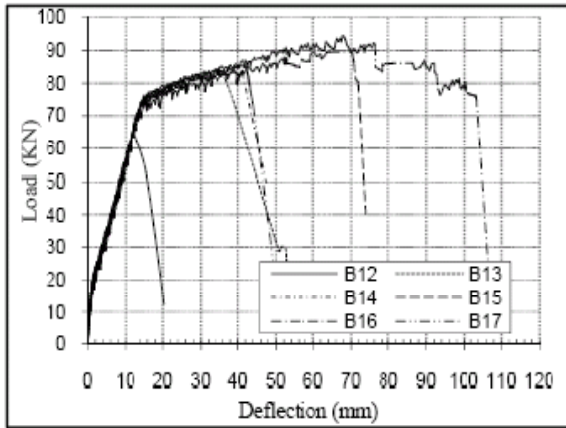

Fig. 11 Load-deflection curves for beam specimens with different shapes of stirrups in splice region

### C. Displacement Ductility

Referring to in Fig. 12, displacement ductility ratio ( $\mu$ ) is defined as the ratio of the maximum deflection (the deflection when the load decreased to 80% of the ultimate value along the descending branch of the load deflection curve) and the deflection at the point of yield of reinforcement steel [11]. The displacement ductility for the tested beams is shown in Table III.

As indicated by comparison of test results of beam specimens with different concrete compressive strength, the displacement ductility increased as the concrete compressive strength increased and this increasing was more rapidly with the presence of transverse reinforcement in the splice region. The displacement ductility drastically decreased when the lap splice length decreases to two-thirds that required by ACI code. A comparison of beam specimens with variable spacing between vertical transverse reinforcement in the splice region, indicated that the displacement ductility increased with increasing the amount of vertical transverse reinforcement crossing the potential splitting plane in the splice region. The greatest increasing in the displacement ductility was when stirrups around spliced bars used in the splice region, especially continuous spiral around each spliced bar B16 and two interlocking spirals around spliced bars B15.

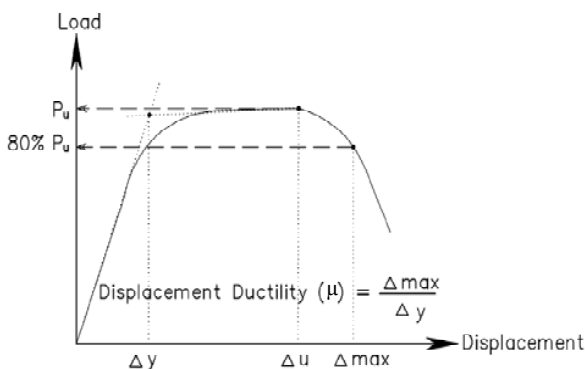

Fig. 12 Definition of displacement ductility

### D. Stresses in the Sliced Bars

The average stresses in the spliced bars at ultimate load  $p_u$  was calculated using the rectangular stress block for concrete given in ACI 318-05 with safety factors taken as 1.0. Reinforcement stresses is obtained from the maximum applied moment for the concrete strengths used in this investigation. A quadratic expression is used to determine the tensile force in longitudinal reinforcement, which is divided by the total area of reinforcement at a section outside the splice zone to obtain the average reinforcement stresses at ultimate load. Table III shows the stresses in the spliced bars for beam specimens.

### IV. COMPARISON WITH ACI 318-05

The stresses in spliced bars from the experimental program were compared to those calculated using ACI 318-05 design provisions. The development length  $l_d$  in the ACI code was replaced by  $l_s / 1.3$  to account for the bar casting position, which is given as follows:

$$\frac{l_d}{d_b} = \frac{9}{10} \frac{f_y}{\sqrt{f'_c}} \frac{\lambda}{c + k_{tr}} \quad (1)$$

$$\frac{(c + K_{tr})}{d_b} \leq 2.5 ; K_{tr} = \frac{A_{tr} f_{yt}}{10 s n}$$

where,

$f_y$  = yield strength of the reinforcement steel which could be replaced by  $f_s$  to evaluate the stress in the reinforcing bar for a given splice length,  $l_s$ , MPa;

$f_{yt}$  = yield strength of transverse reinforcement, MPa;

$f'_c$  = cylinder compressive strength of the concrete, MPa;

$\gamma$  = reinforcement size factor (= 0.8 For NO. 6 (19mm diameter) and Smaller);

$c$  = spacing or cover diameter, mm;

$K_{tr}$  = transverse reinforcement index;

$A_{tr}$  = total cross section area of all transverse reinforcement that is within the spacing  $s$ , mm<sup>2</sup>;

$n$  = number of bars being spliced or developed along the plane of splitting;

$s$  = center-to-center spacing of transverse reinforcement within splice length, mm.

The predicted steel stress for beam specimens is shown in Table IV. This table also provides the ratios of the experimental stresses to the predicted stresses according to the code equation. For beam specimens exclude beams with stirrups around spliced bars, the average of the ratios of the experimental / predicted stresses is 1.06 with a standard deviation of 0.12. The ACI code underestimates the steel stresses when stirrups added around spliced bars in beam specimens, and for these beams the average of the ratios of the experimental / predicted stresses is 1.61 with a standard deviation of 0.09. This result can be attributed to the high stresses in the reinforcing bars. These high stresses induced high bearing forces on the concrete in the surrounding area of the ribs which can be translated into two components; the horizontal component which cause the bond forces with the

concrete, and the vertical component which causes the splitting forces. These splitting forces are resisted by the vertical transverse reinforcement and stirrups around spliced bars. The contribution of confining stirrups around tension lap splices in high strength concrete in resisting the splitting force have to be evaluated in further experimental study, taken into consideration the different variables.

TABLE IV  
COMPARISON BETWEEN EXPERIMENTAL AND PREDICTED STRESSES IN  
SPLICED BARS

Beam Specimen	Experimental Stresses (Mpa)	Predicted Stresses* (Mpa)	Experimental / Predicted Steel Stresses
B1	375.65	376.04	1.00
B2	460.35	434.92	1.06
B3	467.77	490.31	0.95
B4	383.75	441.38	0.87
B5	492.74	517.65	0.95
B6	538.68	583.25	0.92
B7	493.68	448.27	1.10
B8	531.35	452.26	1.17
B9	541.16	487.86	1.11
B10	369.78	299.90	1.23
B11	360.22	299.76	1.20
B12	380.66	318.03	1.20
mean			1.06
standard deviation			0.12
B13	489.30	315.43	1.55
B14	485.32	317.12	1.53
B15	550.24	320.31	1.72
B16	539.60	321.67	1.68
B17	494.85	318.34	1.55
mean			1.61
standard deviation			0.09

\* According to ACI 318-05

#### IV. CONCLUSIONS

Seventeen high strength concrete beams containing an overlapping splice of two bars under constant bending moment were experimentally studied. Based on the analysis and comparison of mode of failure, ultimate load, load-deflection behavior, displacement ductility and steel stresses in spliced bars, the following conclusions were made:

- 1) The failure of beam without transverse reinforcement was sudden, violent and occurred along the entire length of the splices.
- 2) For splices confined by transverse reinforcement, increasing the concrete compressive strength, the mode of failure was more ductile, and the final mode of failure changed to flexural failure for beam specimen with compressive strength 100 MPa.
- 3) As the amount of transverse reinforcement in the splice region increased, more ductility provided to the mode of failure. For 25% increasing in transverse reinforcement than the required by ACI 318-05, the failure mode changed to flexural failure
- 4) Whatever, the amount of transverse reinforcement in the splice zone, decreasing lap splice length to two-thirds the

required by ACI 318-05, the ultimate load capacity significantly decreased and the mode of failure was splitting failure without any ductility.

- 5) Providing stirrups around spliced bars in beam specimens with lap splice length two-thirds the required by ACI 318-05, the ultimate load capacity increased, mode of failure changed to be flexural ductility, and displacement ductility drastically increased, especially using spiral stirrups either interlocking around spliced bars or continuous around each spliced bar.
- 6) The stiffness of beams with the same compressive strength (resisting to deflection) was identical below and above the flexural cracking load, whatever the lap splice length and the amount of transverse reinforcement in the splice region.
- 7) The steel stresses in spliced bars were well predicted by ACI 318-05 for all beam specimens without stirrups around spliced bars. For these beams, the average experimental /predicted steel stress was 1.06 with standard deviation 0.12. The ACI 318-05 provided underestimate of the steel stresses in beam specimens with transverse reinforcement around spliced bars. For these beams, the average experimental /predicted steel stress was 1.61 with standard deviation 0.09.
- 8) It is recommended to confine the tension lap splice in high strength concrete by spirals stirrups around the spliced bars, especially shorter splices than the required by codes provisions. This confinement will provide ductility to the mode of failure and will significantly improve the load capacity.
- 9) It is desirable that the further work proposed a factor reflect the contribution of confining transverse reinforcement around spliced bars in the design equations for tension lap splice length.

#### REFERENCES

- [1] ACI 318-05, "Building Code Requirements for Structural concrete and commentary," American Concrete Institute, Farmington Hills, Mich, 2005.
- [2] Diab, A. M., "Lap Splices in Reinforced Concrete Beams Subjected to Bending," Master thesis, University of Alexandria, Egypt, 2008.
- [3] Esfahani, M. R., Rangan, B.V., "Bond between Normal Strength and High-Strength Concrete (HSC) and Reinforcing Bars in Splices in Beams," ACI Structural Journal, V. 95, No. 3, May-June 1998, pp. 272-280.
- [4] Azizinamini, A., Darwin, D., Eligehausen, R., Pavel, P., Ghosh, S. K., "Proposed Modifications to ACI 318-95 Tension Development and Lap Splice for High-Strength Concrete," ACI Structural Journal, V. 96, No. 6, Nov.-Dec. 1999, pp. 922-926.
- [5] Zuo, j., Dawin, D., "Splice Strength of Conventional and High Relative Rib Area Bars in Normal and High-Strength Concrete," ACI Structural Journal, V. 97, No. 4, July-August 2000, pp. 630-641.
- [6] Hamad, B. S., Najjar, S., "Evaluation of the Role of Transverse Reinforcement in Confining Tension Lap Splices in High Strength Concrete," Materials and Structures, V. 35, May 2002, pp. 219-228.
- [7] Turk, K., Yildirim, M. S., "Bond Strength of Reinforcement in Splices in Beams," Structural Engineering and Mechanics, V. 16, 2002, No. 4.
- [8] ACI Committee 408, "Bond and Development of Straight Reinforcing Bars in Tension," ACI 408R-03, American Concrete Institute, Farmington Hills, Mich, 2003.
- [9] Azizinamini, A., Stark, M., Roller, J. H. and Ghosh, S. K., "Bond Performance of Reinforcing Bars Embedded in High-Strength

Concrete,” ACI Structural Journal, V.90, No.5, Sept.-Oct. 1993, pp. 554-561.

- [10] Azizinamini, A., Chisala, M., Roller, J. H., and Ghosh, S. K., “Tension Development Length of Reinforcing Bars Embedded in High-Strength Concrete,” Engineering Structures, V. 17, No. 7, 1995, pp. 512-522.
- [11] Park, R., Ruitong, D., “Ductility of Doubly Reinforced Concrete Beam Sections,” ACI Structural Journal, V.85, No.3, March-April 1998, pp. 217-225.