

Effect of Highly Pressurized Dispersion Arc Nozzle on Breakup of Oil Leakage in Offshore

N. M. M. Ammar, S. M. Mustaqim, N. M. Nadzir

Abstract—The most important problem occurs on oil spills in sea water is to reduce the oil spills size. This study deals with the development of high pressurized nozzle using dispersion method for oil leakage in offshore. 3D numerical simulation results were obtained using ANSYS Fluent 13.0 code and correlate with the experimental data for validation. This paper studies the contribution of the process on flow speed and pressure of the flow from two different geometrical designs of nozzles and to generate a spray pattern suitable for dispersant application. Factor of size distribution of droplets generated by the nozzle is calculated using pressures ranging from 2 to 6 bars. Results obtain from both analyses shows a significant spray pattern and flow distribution as well as distance. Results also show a significant contribution on the effect of oil leakage in terms of the diameter of the oil spills break up.

Keywords—Arc Nozzle, CFD simulation, Droplets, Oil Spills.

I. INTRODUCTION

THERE are many progressive reaction mechanisms available in monitoring oil spills. These systems have greatly influences the environment disorder and improve ocean life. In order to remove oil spills effectively, it has to come with careful choices and appropriate usage of the materials and equipment to counter the kind of oil and the situations on the spill location. Such factors of location are for example the situation of water streams, sea and the disturbance of the wind. In another case, a chemical method is relevant to be used in breaking up the oil spills. This chemical method, the dispersing agents is certainly a great solution in portion to retain oil from reaching shores and other sensitive environments [1].

Though, very small work has been made to ensure that the chemical is applied effectively onto the oil spills. Most of the mechanism does not produce sprays with evenly droplet sizes chemicals for effective breaking the oil spills sizes. Another difficulty of finding the correct mechanism is to obtain the capability of breaking oil spills into very small particles. Smaller particles migrate longer onto the sea surface compared with larger particles of oil [2].

Finally, to improve the problem, the mechanism should acquire the capacity to transfer chemicals in longer range so that spray pattern can produce widely towards the oil spills. Longer range drops could be used to advantage during non-windy spray conditions to reduce dispersant loss and improve the ability to place the dispersant on the target oil spills [2].

N.M.M.Ammar, S. M. Mustaqim, and N. M. Nadzir are with the Universiti Malaysia Pahang, Pekan, CO 26000, Malaysia (phone: 60-424-6264; fax: 60-424-2222; e-mail: ammar@ump.edu.my, mustaqim@ump.edu.my, Nadzir@ump.edu.my).

Past researchers that have analyze this cause were mostly done using fire-fighting system on vessels [1]. Result show that weak in the ability to manage spraying oil spills evenly from the discharge point out to the full reach of the spray pattern and produces much small drop size and range distance [2]. Some researchers analyze using wire mesh type nozzle, but produces smaller flow rate thus small fallout distribution [3], [4].

Though, a lot of researches has done this via experiment, But with high cost and time consuming, as well weakness in determining the oil slick size distribution, many research have come towards short results.

To overcome this cause, CFD may well be the best option for analyzing new designs and inventions [6]. To analyze the size of these droplets influences if and when they will reach the surface or stay dispersed in the water for a long period, CFD are best solution or option at the moment.

In the current investigation, alternative methods have been sought in an attempt to improve in the application of nozzles that could consistently deliver the proper spray under a range of application conditions [5].

As a starting point, an arc shape with the inclusion of some specific convergent-divergent nozzle inlet design was identified as a possible solution and was acquired for testing purposes using experimental and CFD analysis. The design of the nozzle with the implementation of arc was based from the literature to improve its wide distribution, length variation and chemical atomization [7], [8].

II. METHOD

A. Design of Nozzles

The nozzles (Nozzle A and B) presented in this research consist of 4 main parts with a cylindrical cross section shown in Fig. 1. The main part is the outlet holes (1), arc nozzle outlet (2), connectors (3) and cylindrical hollow chambers (4) shown in Fig. 2 below. Main body starting from the nozzle inlet to nozzle outlet has an inlet diameter of 25 mm and length of 210 mm long. The outlet holes diameter is 5mm. The arc nozzle outlet length from the outlet holes is 80 mm. The difference of design between nozzle A and B is the cylindrical hollow chamber. For nozzle B, the outlet chamber is 18 mm, a 60° tapered angle from the inlet chamber. Nozzle B also differs at the numbers of outlet holes and the numbers of outlet arcs. The configurations of nozzle A and B are shown in Fig. 3 below. Dispersion enters from the connectors to the outlet arc to produce atomized dispersion droplets.

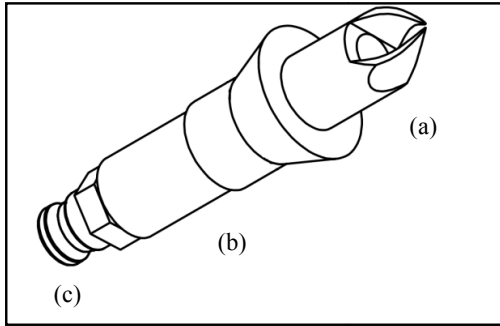

Fig. 1 Nozzle design (a), nozzle head (b) and the nozzle body (c) connectors.

Dispersant chemicals enters with pressure ranging from 2 bars to 6 bars for (c) in Fig. 1 and is atomized through the outlet diameter at (a) before sprayed in a coned shaped by the arc.

In order to determine the fluid flow behavior, the pressure of the flow was simulated using ANSYS 13.0 program and Fluid Flow (CFX) analysis method. For numerical analysis, design of the nozzle was created using Solidworks Software package as a solid boundary (inlet) and the mesh with ANSYS 13.0.

For validation, experiment was done by fabricating the nozzle. The setup was set so that nozzle is staged vertically in the experiment apparatus. The nozzle created was with 4 holes and 4 arcs and a straight duct shown in Fig. 3 (Nozzle A).

B. Grid Generation and Meshing

The nozzles were divided into many elements of cells. Each cell is contributed with the conservation equation of Navier-Stokes Equation through discretization process. Each cell contributes to the variables of velocity, pressure, etc. For this analysis, the cells are categorized into tetragonal elements and it is assumed that the flow is isothermal and incompressible. Figs. 4 (a) and (b) show the grid analysis.

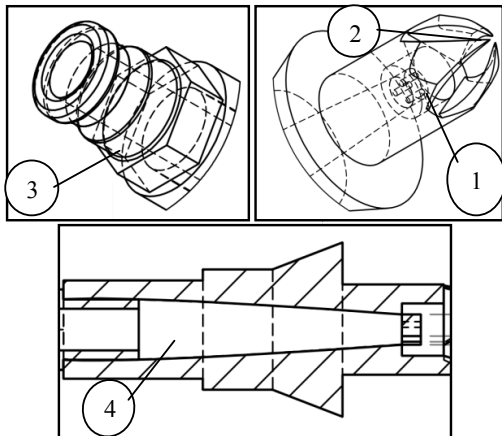

Fig. 2 Nozzle (1: the outlet holes, 2: arc nozzle outlet, 3: connectors, 4: cylindrical hollow chambers)

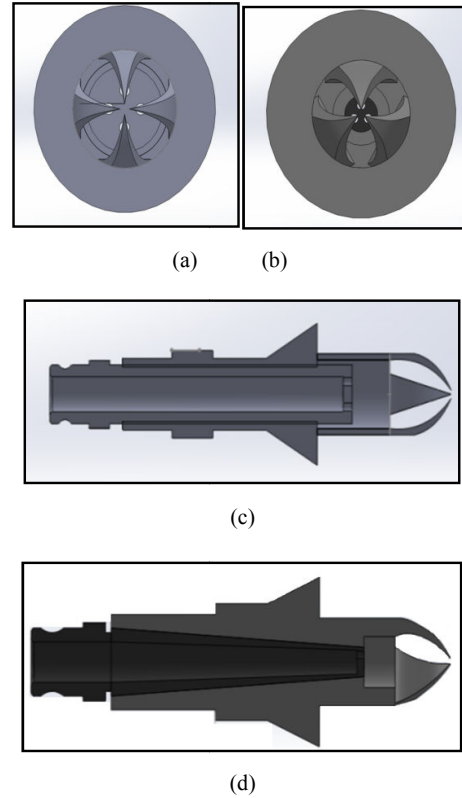

Fig. 3 (a) and (c), Nozzle A with 4 outlet holes and straight cylindrical hollow chamber, (b) and (d) Nozzle B with 4 outlet holes and tapered cylindrical hollow chamber.

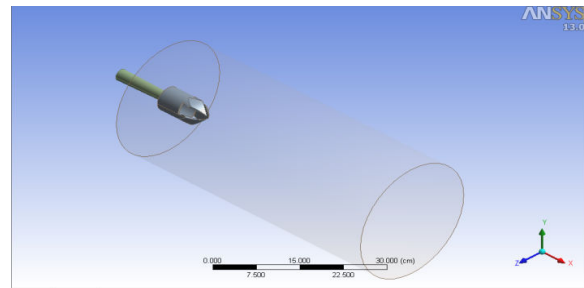

Fig. 4 (a) Boundary condition of meshing grids

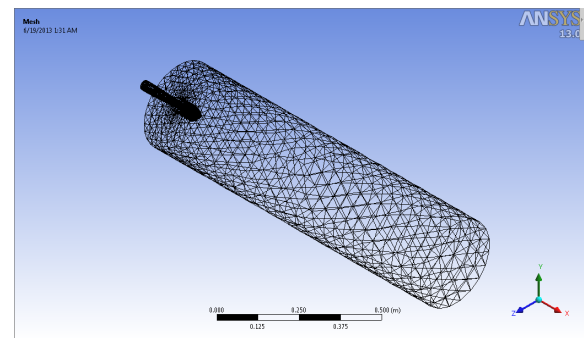

Fig. 4 (b) Meshing analysis

The meshing grid solution is dependent on the quality of the grid. Sharp edge shape is difficult to construct and thus may have difficulties in obtaining the convergence criteria. The mesh is set so that the final grid would be very fine and well structured. The mesh was built with finite volumes ranging from 150,000 to 700,000 grids. The most effective grids with the consideration of time consumption were 421,343 grids.

C. Numerical Analysis: Turbulence Models

Standard k- ϵ and modified k- ϵ turbulent models is widely used for the numerical analyses of pressurized nozzle [3]. Although, the modified k- ϵ model is more sensitive in the region if strong streamlines with curves [9]. In terms of transport equations for turbulent, both models are the same except for the constants. The models are derived from statistical techniques. It is replaced by the function of $C_{\epsilon 1RNG}$. The transport equation becomes:

$$\frac{\partial}{\partial t}(\rho\epsilon) + \frac{\partial}{\partial x_i}(\rho u_i \epsilon) = \frac{\partial}{\partial x_i} \left[\left(\mu + \frac{\mu}{\sigma_{\epsilon RNG}} \right) \frac{\partial \epsilon}{\partial x_i} \right] + C_{\epsilon 1RNG} \frac{\epsilon}{k} G_k \dots \dots - C_{\epsilon 2RNG} \rho \frac{\epsilon^2}{k} \quad (1)$$

With constant determined empirically to be:

$$C_{\epsilon 1RNG} \frac{\epsilon}{k} = 1.063, \text{ and } C_{\epsilon 2RNG} \frac{\epsilon}{k} = 1.92$$

D. Boundary Conditions

For Boundary conditions, the inflow and outflow area with velocity and pressure conditions are specified at the boundaries at which the fluid enters the computational domain or leaves the domain. This study used the measured data from the experiment for fluid volumetric flow rate. The pressure was taken using a gage pressure from the pipe into the connectors. For the numerical analysis, the total pressure was specified at the nozzle inlet in which the flow was coming into the computational domain from the pump.

The arc nozzle in this work was set as air and the tunnel was set as wall. The rest of the geometry was also set as plane. The Wall boundary condition was assumed to be Nonslip boundary condition and was applied to the nozzle walls.

III. MODEL VALIDATION

Fig. 5 presents comparison of experimental data and simulations results for nozzle flow. The 4 arc nozzle was fabricated with specific design and experimented for data. The relationship of pressure versus flow rate at inlet give good agreement compared to test data. Although at high pressures, the flow rate differs from the numerical. This can be explained by the head loss and loss friction coefficient in the nozzle from experiment analysis.



(a)

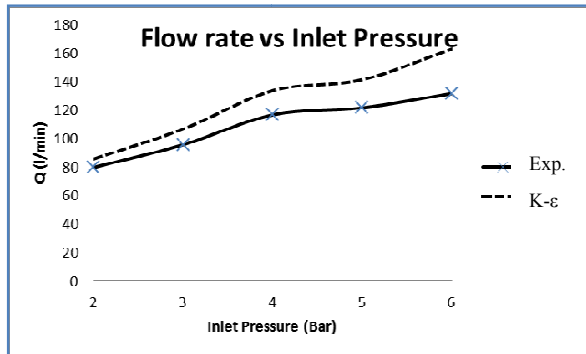

(b)

Fig. 5 (a) and (b) Flow rate and pressure correlation of 4 arc nozzle with experiment and numerical analysis.

IV. RESULTS AND DISCUSSION

A. Speed of the Flow

In this field of study, the analysis has been done to analyze the velocity streamlines inside and along the nozzles body. The fluid is flowing in the inlet of the nozzle with velocity that was obtained as 4.39ms^{-1} taken after the flow is steady for pressure of 3 bars. The streamlines are field lines that are instantaneous tangent to the velocity vector of the flow. The streamline represent the flow behavior of water which go through both nozzles and follow the path along the nozzles. The result from the modeling of water streamlines is as shown in Figs. 5 and 6.

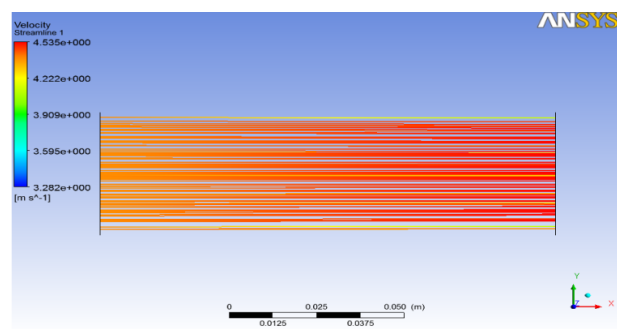

Fig. 6 Velocity streamline in 4 arc nozzle

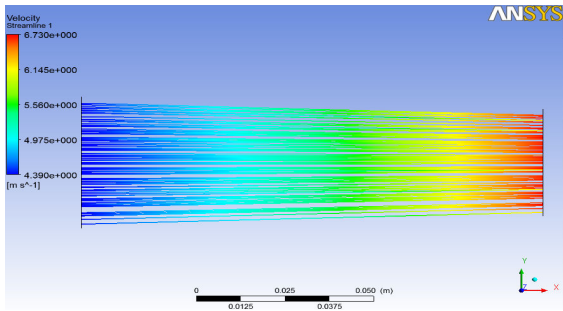

Fig. 7 Velocity streamline in 3 arc nozzle

From Figs. 6 and 7, there are 100 streamlines that are being analyzed for this analysis. The streamlines is traced by a moving particle at every point along the path from inlet to outlet. The pattern of flow is seen smooth according to there are no disturbance but become rapidly mixed as the flow of water go through along the path. This analysis concludes that the flow speed increases as the direction increases. For 3 arc nozzle, the speed increase from initial velocity of 4.39 m/s to 6.73 m/s. Compared to 4 arc nozzle, the velocity remains 4.39 m/s before it enters the holes of the arc.

To visualize the speed after the Fig. 8 shows the velocity and streamline for 3 arc nozzle using numerical analysis. The analysis shows the streamlines trajectory from the arc to the outlet via streamline projection and graph of velocity versus length. The results indicate that the velocity increases rapidly after the flow from the inlet body to the arc holes. The velocity increases up to 98% from its original velocity of 4.39m/s to 245 m/s. The increment in velocity indicated the process of atomization and separating to form a spray angle after the nozzle arc. The velocity reduces to zero as the boundary condition is taken into consideration.

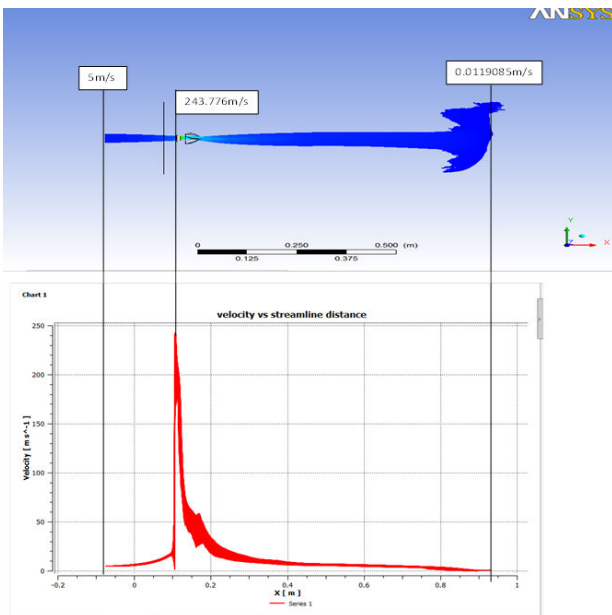

Fig. 8 (a) and (b) Graph of Velocity versus Streamline for 3 arc nozzle

B. Pressure Outlet

The effects of pressure variation play an important role in analyzing the data for deflection angle. The deflection angle are used to discuss on the spray angle analysis for the purpose of evenly spray on the oil spills.

Performances of the results are summarized in Table I and Fig. 9 by variation of inlet pressure at nozzle and Angle of Deflection from the arc nozzle. From Fig. 9 a comparison of the experiment of 4 arc nozzle with the analysis of 3 arc nozzle shows that for both nozzle designs, increases of pressure exhibit in a smaller angle deflection. At 4 bar of pressure, both angle exhibit the same deflection angle. In the beginning, the 4 arc nozzle tends to produce smaller angle of deflection compared to 3 arc nozzle. But as pressure is increase to 6 bars, the angle of deflection for 3 arc nozzle produce small angle compared to 4 arc nozzle. This shows that both are capable of make differences in producing a large spray pattern in different pressure. Although it is require that a larger spray angle at a smaller pressure is more useful in smaller water craft for evenly spray pattern on the oil spills.

TABLE I
PRESSURE ANALYSIS WITH ANGLE OF DEFLECTION OF THE FLOW

No. of Exp.	Pressure (Bar)	Angle of Deflection (°)	
		4 arc	3 arc
1	2	43	47
2	3	41	45
3	4	40	40.5
4	5	38	32
5	6	35	30

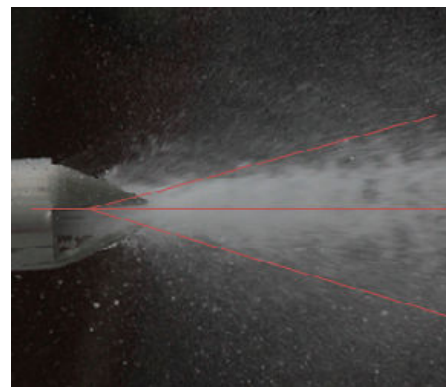

(a)

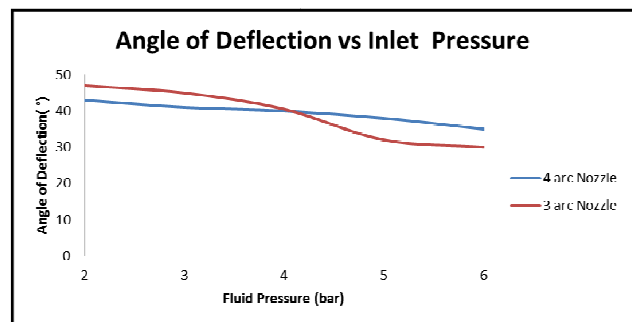

Fig. 9 (a) and (b) Angle of deflection against Inlet pressure

C. Spray Range

For comparison of the spray range, Table II below show the difference in the correlation for pressure against spray length. From the experiment, it shows that the 3 arc nozzle improve about 20 percent compared to the 4 arc Nozzle because the longest projection of the new nozzle is about 21m while for 4 arc Nozzle is about 18m.

In the calculation, it can be proved that the 3 arc nozzle can improve about 100 percent compared to the 4 arc Nozzle but in the real situation, it is only about 20 percent of improvement. This is because in the calculation, all the circumstances are neglected including friction, wind and etc.

TABLE II
COMPARISON OF NOZZLES FOR SPRAY RANGE

NOZZLE	PRESSURE (BAR)		
	3	4	5
4 arc Nozzle	14m	17m	18m
3 arc nozzle	16m	17m	20m

D. Droplets Breakup

In numerical analysis, it may have difficulties in producing the oil breakup due to average computers and low graphics acceleration. So, in order to analyze the oil spills breakup, the experiment using 4 arc nozzle was done and discuss in this paper.

From Fig. 10, it shows that the oil slicks dispersed into small particles due to the resistance for the fluid from the nozzle. Once they are dispersed, the tiny droplets of oil are more likely to sink or remain suspended in deep water rather than floating to the surface and collecting in a continuous slick. Dispersed oil can spread quickly and dissipated by waves and turbulence that break it up further. Time taken for the oil slick to break up was measured to be 2 seconds after the fluid had been ejected to the oil spills.

V. CONCLUSION

The comparison between both designs shows that the 3 arc nozzle is slightly better than the 4 arc nozzle. The improvement that can be seen were the distance of discharged water, the size of the water droplet is decrease and the spray cone angle is smaller which allow the discharged water to go further as compared to the 4 arc nozzle.

According to the result that has been analyzed, several recommendations can be issued in order to make some improvement such as the distance of water discharged and also to make the result more reliable and reduce the percentage error of the experiment.

Some recommendations that can be further improving the experiment for this research are, manipulating the angle of nozzle on the interior of the nozzle or experimental on the action of chemical which is called dispersant on oil. The studies of this field still need to be improved and there are still scopes for further study.



(a)



(b)



(c)



(d)

Fig. 10 (a), (b), (c) and (d) Angle of deflection against Inlet pressure

ACKNOWLEDGMENT

This work is supported by the grants from Universiti Malaysia Pahang (Project No: RDU1203102). The Authors would also wish to express their thanks to Fire Department, Pekan District, Pekan for offering testing services and contributions to the study.

REFERENCES

- [1] Lunel, T.,L. Davies, A.C.T. Chen and R.A. Major, "Field Test of Dispersant Application by Fire Monitor" Proceedings of Eighteenth Arctic and Marine Oil spill Program (AMOP) Technical seminar, Environment Canada, Ottawa, ONt., pp. 559-602, 1995
- [2] Marucci, T.F., R.A. Major, and N.R. Gray, Land Tests of Dispersant Application by Fire Monitor, Exxon Production Research Company, Houston, TX, Report Numer EPR.33PS.91, 1991.
- [3] Cruz, N., Briens, C., & Berruti, F. (2010). Supersonic attrition nozzles in gas–solid fluidized beds. *Chemical Engineering and Processing: Process Intensification*, 49(3), 225-234. doi: 10.1016/j.cep.2010.01.010
- [4] Faeth, G. M., Hsiang, L. P., Wu, P. K., (1995) "Structure and Breakup Properties of Sprays", *International Journal of Multiphase Flow*, Vol. 21, pp. 99-127.
- [5] Hiroyasu, H., Arai, M., (1990) "Structures of Fuel Sprays in Diesel Engines", *SAE Paper 900475*.
- [6] Meroney, R. N. (2012). CFD modeling of water spray interaction with dense gas plumes. *Atmospheric Environment*, 54, 706-713. doi: 10.1016/j.atmosenv.2012.01.038
- [7] Pougatch, K., Salcudean, M., & McMillan, J. (2011). Nozzle design influence on particle attrition by a supersonic steam jet. *Powder Technology*, 209(1-3), 35-45. doi: 10.1016/j.powtec.2011.01.024

- [8] Rana, M. A., Guo, Y., & Mannan, M. S. (2010). Use of water spray curtain to disperse LNG vapor clouds. *Journal of Loss Prevention in the Process Industries*, 23(1), 77-88. doi: 10.1016/j.jlp.2009.06.003
- [9] V. Yakhot and L. Smith, "The renormalization group, the ε -expansion and derivation of turbulence models," *Journal of Scientific Computing*, vol 7, pp. 35-61, 1992/03/01 1992.