

Effect of Friction Stir Welding on Microstructural and Mechanical Properties of Copper Alloy

Dhananjayulu Avula, Ratnesh Kumar Raj Singh, D.K.Dwivedi, N.K.Mehta

Abstract—This study demonstrates the feasibility of joining the commercial pure copper plates by friction stir welding (FSW). Microstructure, microhardness and tensile properties in terms of the joint efficiency were found 94.03 % compare to as receive base material (BM). The average hardness at the top was higher than bottom. Hardness of weld zone was higher than the base material. Different microstructure zones were revealed by optical microscopy and scanning electron microscopy. The stirred zone (SZ) exhibited primary two phases namely, recrystallized grains and fine precipitates in matrix of copper.

Keywords—Welding; FSW; Commercial Copper; Mechanical properties

I. INTRODUCTION

FRICITION stir welding (FSW) is a new solid state welding process, where the weld is produced by softening, plastic deformation combined with forging action caused by tool rotation of base metal (Fig. 1) [1-3]. Absence of melting of base metal in FSW reduces oxidation, residual stress, solidification related defects. The microstructure of the weld generally shows a central weld nugget with onion ring structure, a thermo-mechanically affected zone (TMAZ) close to the nugget, and a very small heat affected zone (HAZ) [4].

Recently many reports on friction stir welding of various metal system such as aluminium [5-10], magnesium [11-12], mild steel [13], stainless steel [14], and dissimilar systems such as aluminium to stainless steel [15], aluminium to steel [16], aluminium to copper [17], aluminium to magnesium [18], have been published. Preliminary studies on the FSW for copper to copper [19-21] and brass [22-23] have also been reported. Copper and its alloys are widely used in industrial applications due to their excellent electrical and thermal conductivities, good strength, and corrosion and fatigue resistances.

D. K. Dwivedi is with Department of Mechanical and Industrial Engineering, Indian Institute of Technology, Roorkee, Roorkee, India.
e-mail: dkd04fme@iitr.ernet.in

However, welding of copper is usually difficult by conventional fusion welding techniques because of its high thermal diffusivity, which is 10–100 times higher than that of steels. Hence, the heat input required for welding of copper alloys is much higher, resulting in quite low welding speeds. Higher thermal conductivity and thermal expansion of copper result in greater weld distortion than steel [24-26].

During arc welding of copper and copper alloys, oxygen segregates on grain boundaries of metal. This can lead to embrittlement of the weld joint. Precipitation hardenable copper alloys may lose their alloying elements (Zn) through oxidation during fusion welding, compromising their strength. Copper welds frequently suffer from lack of fusion because of the high thermal conductivity of copper as it reduces the concentration of heat needed to melt a critical mass of metal and ensures complete filling of the weld cavity.

Recently for few industrial applications, FSW has been successfully used for joining copper e.g. fabrication of the copper containment canister for nuclear waste [27] and the backing plate for sputtering equipment [28].

In view of huge commercial importance of copper alloys and required for joining for fabrication of engineering components in this study, attempts were made to study the effect of friction stir welding of copper on microstructure of the copper weld joints using optical microscope and scanning electron microscopy (SEM), mechanical properties such as microhardness and tensile strength. Further, effort was made to establish the structure Properties relationship.

II. EXPERIMENTAL PROCEDURE

In this study, commercial pure copper sheet of 100 mm length, 40 mm width and 6 mm thickness in heat treated condition were welded by friction stir welding process. Nominal composition of copper plate is shown in Table 1. For heat treatment copper plates were kept in furnace at 600°C for 30 min and followed by water quenching at room temperature.

The welds were developed in square butt joint configuration. Facing surfaces of Copper sheet were first machined then cleaned by acetone before fixing on backing plate with help of indigenously designed and fabricated fixture. Geometry of die

steel tool used for friction stir welding is shown in Fig. 2 (Table 2). Tool rotational speed was kept constant at 635 rpm in clockwise direction and welding speed was varied.

Welds were developed using two welding speeds i.e. 8 and 19 mm/min. The tool axis was tilted by 3° from normal to surface of base plate. The stirrer pin was positioned at centre line along the line of weld.

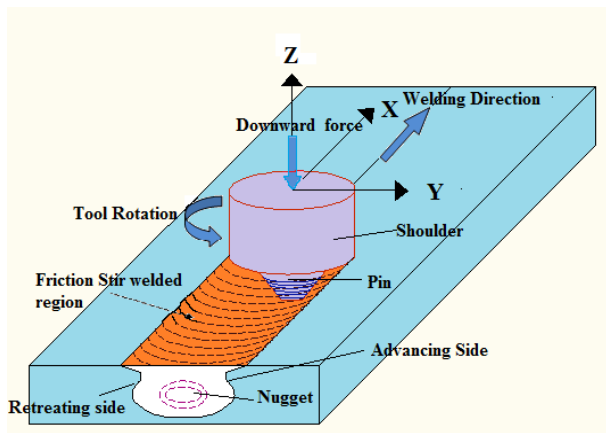

Fig.1 Friction Stir Welding

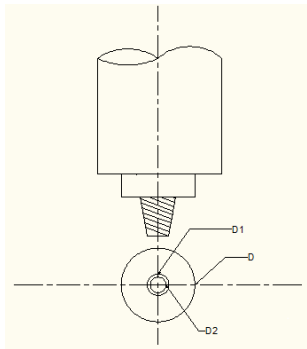

Fig. 2 Schematic diagram showing geometry of Die steel FSW tool

TABLE I
CHEMICAL COMPOSITION OF BASE METAL

Elements	Mg	Al	Si	Cr	Mn	Cu
Weight %	0.29	0.42	0.24	0.54	0.47	98.05

TABLE II
DIMENSION OF TOOL

Tool Material	Die steel
Shoulder diameter (D)	15 mm (right hand)
Pin maximum diameter (D1)	6 mm
Pin minimum diameter (D2)	4 mm
Pin length (L)	5.6 mm
Thread Pitch	1 mm (Right Hand)

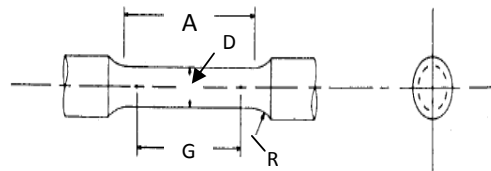

Fig. 3 Schematic diagram showing geometry of tensile test Specimen

TABLE III
DIMENSION OF TENSILE TEST SAMPLE

Gage length (G)	20 mm
Diameter (D)	4 mm
Radius of fillet (R)	4 mm
Length of reduced section (A)	24 mm

Welded plates were cut from transverse direction using power saw to prepare samples for microstructural and mechanical examination. For microstructural examination samples were polished using standard metallographic procedures and then polished samples are etched with the nitric acid. Etched samples were then examined using optical microscope and scanning electron microscope.

The Vickers microhardness of base material in as received and heat treated condition that of weldments was measured at a load of 200 grams for a dwell time of 30 second. Hardness was measured both in transverse direction of weld and in thickness direction from top to bottom at centre of weld nugget. The tensile tests on the joint were performed using samples prepared according to ASTM E8M-04 specifications having 4 mm gauge diameter and 20 mm gauge length (Fig. 3). Table 3 shows the dimensions of tensile test sample. Scanning electron microscopy was used for factography of tensile fracture surfaces.

III. RESULTS AND DISCUSSION

3.1 Microstructure

Heat treated copper sheets were successfully welded in the butt joint configuration by friction stir welding. Defect-free weld joint was obtained at tool rotational speed of 635 rpm and travel speed of 19 mm/min (Fig. 4a). While few weld defects such as voids, cavities were observed in weld produced at 8 mm/min welding speed (Fig. 4b). The microstructure of the weld joint of copper revealed different zones namely (a) weld nugget (WN), (b) thermo-mechanically affected zone (TMAZ), (c) heat-affected zone (HAZ) and (d) Base material (BM).

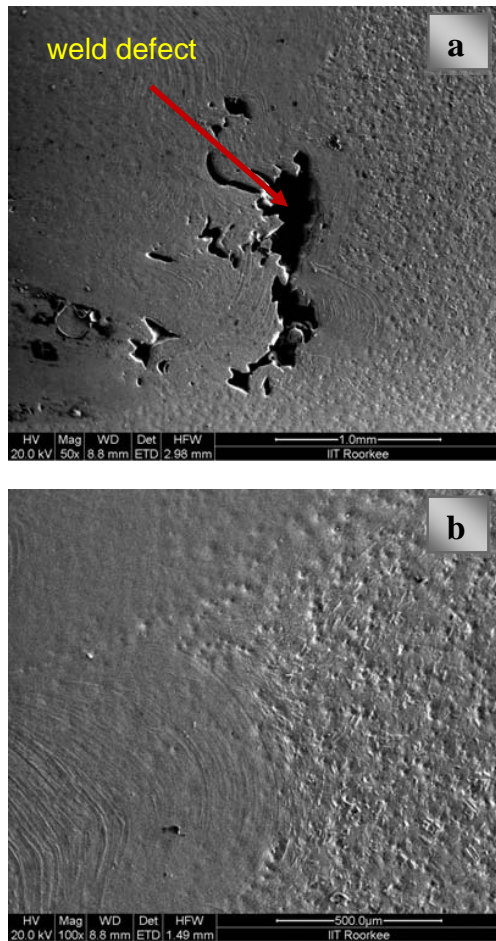

Fig. 4 (a) Defect in weld producing with 8 mm/min welding speed, (b) defect free weld producing at 19 mm/min welding speed

3.1.1 Optical Microscopy

The microstructures of copper alloy sheets under study in as-received and heat-treated condition are shown in Fig. 5 (a, b) respectively. It can be observed that there are certain precipitates in matrix of copper in both as-received and heat-treated condition. Image analysis of micrographs exhibited that heat treatment of base metal increases average size of precipitates from 22.14 μm to 30.91 μm as compared to that of as-received base metal. Microstructures of weld joint of copper base metal at different zone are shown in Fig. 5 (c-f).

Micrographs of weld joints showed precipitates of different sizes in different regions. In weld nugget zone precipitates were finer as compared to base material because dynamic stirring force of tool pin breaks the precipitates to smaller size. At 8 mm welding speed, the average precipitate size was lower (12.59 μm) than that obtained at 19 mm welding speed

(15.62 μm). Finer precipitates size at low welding speed than high welding speed is mainly due to the fact that at low welding speed tool have more time to stir the material. Slow stirring action more effect in breaking of precipitates takes that of at high speed. Thermo-mechanically affected zone on advancing side showed larger precipitates (average precipitate size was 43.42 μm) as compared to retreating side (average precipitate size was 26.96 μm) in weld joint produced using 8 mm/min welding speed. Weld joint produced using 19 mm/min welding speed precipitates size in weld joint in both side (advancing/retreating) were marginally different. The average precipitate size in advancing side was 34.38 μm while that in retreating side was 30.37 μm .

3.1.2 Scanning Electron Microscopy

Nugget zone showed very fine and recrystallized grains. Microstructures of different zone of friction stir welded copper are shown in Fig. 6 (a-d). It can be seen that thermo-mechanically affected zone is plastically deformed and thermally affected. The elongated grains were observed at thermo-mechanically affected zone on both advancing and retreating side of the weld produced at both welding speed (Fig 6 a-d). The advancing side of thermo-mechanically affected zone than the retreating side showed longer and elongated grains were observed at the advancing side of thermo-mechanically affected zone, which is roughly transverse to the parent metal grains. Clear boundary exhibits both advancing and retreating side with the weld nugget. Mukhopadhyay et al., (2006) and Colligan, (1999) found the same type of micrographs during friction stir welding [29-30]. Adjacent to the thermo-mechanically affected zone coarse grains were observed in heat affected zone as shown in Fig. 6(b, c). Fig. 7 illustrates the onion ring flow pattern in the weld zone at 8 mm/min welding speed.

3.2 Hardness

Hardness of base metal, weld nugget in transverse and in thickness direction is shown in Fig. 8 (a-c). It can be observed that heat treatment decreases hardness of base metal from 97 to 61HV₂₀₀. Hardness of nugget was found to vary significantly because of nonuniform plastic deformation of material in different zone. The hardness in weld nugget was in general higher than the base material due to the two effects a) Grain refinement in weld nugget follows the Hall-Petch equation and b) Work hardening due

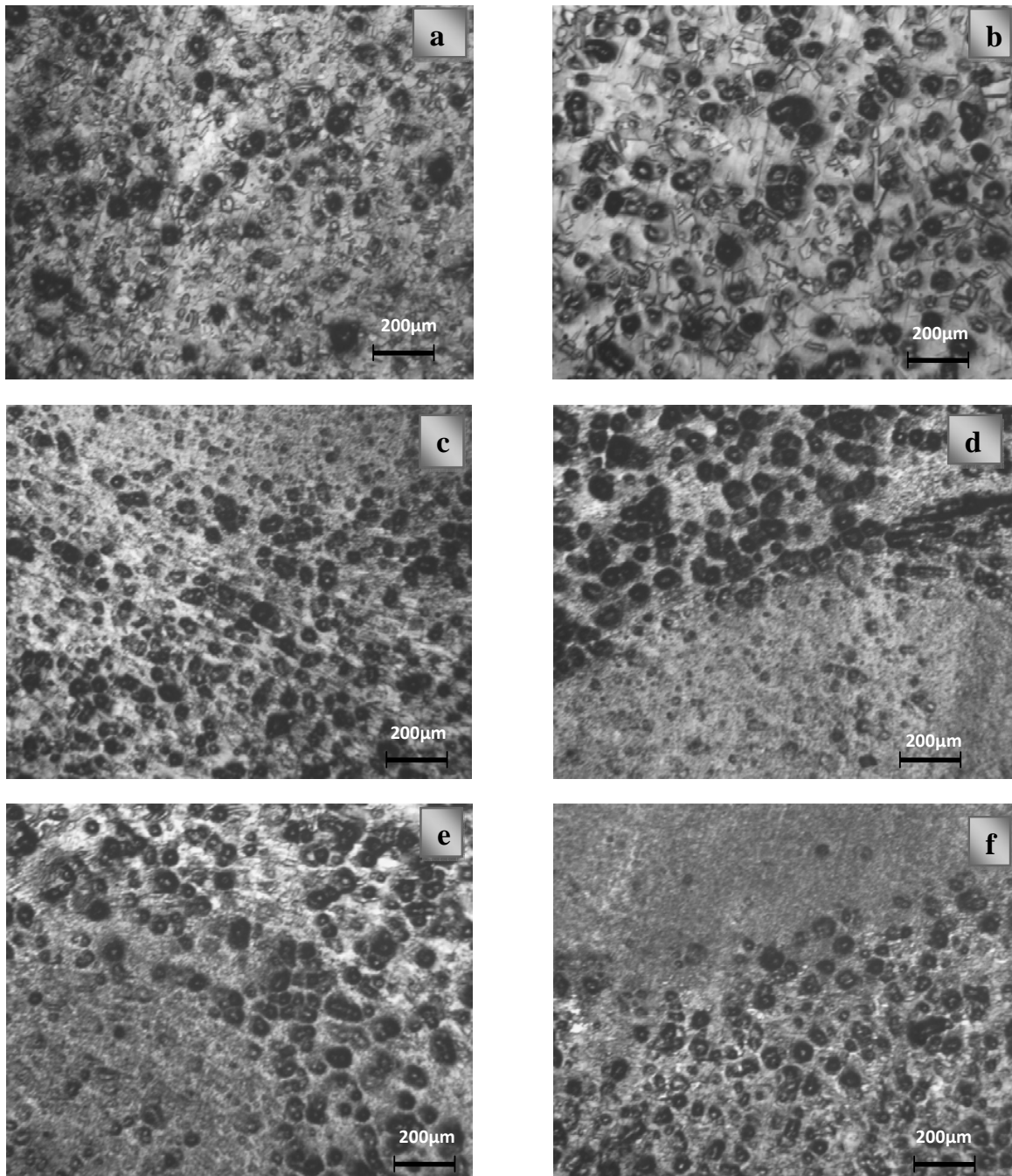

Fig. 5 Micrographs of weld by optical microscopy, (a) Base Material, (b) Heat treated base material, (c) Interface in advancing side (8 mm/min welding speed), (d) Interface in retreating side (8 mm/min welding speed), (e) Interface in advancing side (19 mm/min welding speed), (f) Interface in retreating side (19 mm/min WS)

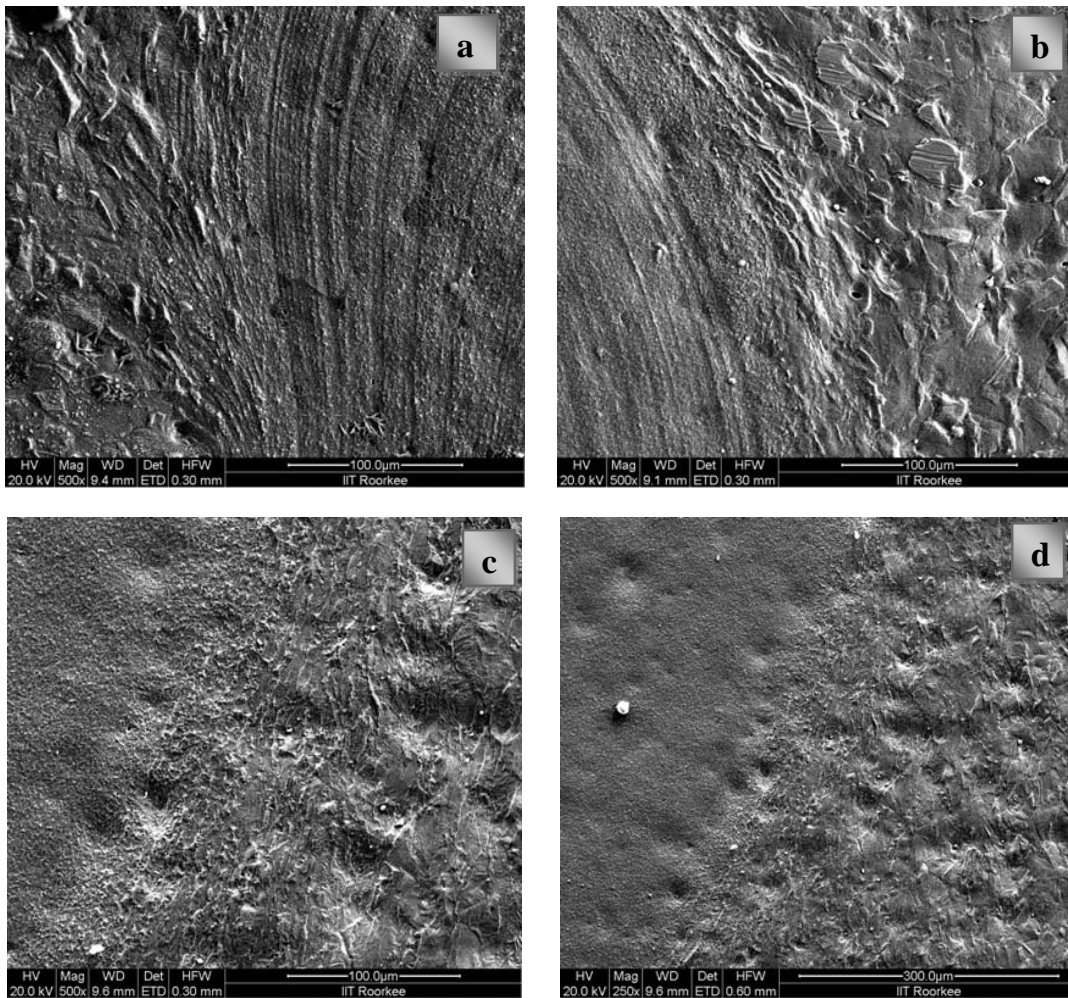

Fig. 6 SEM micrograph of weld joint showing weld nugget, thermo-mechanically affected zone and heat affected zone in (a) weld produced using 8 mm/min welding speed in advancing side (b) weld produced using 8 mm/min welding speed in retreating side, (c) weld produced using 19 mm/min welding speed in advancing side, (d) weld produced using 19 mm/min welding speed in retreating side

to plastic deformation. The maximum hardness was found in retreating side of weld nugget at both welding speeds. The hardness of weld nugget produced using lower welding speed (8 mm/min) was found to be more than that produced using higher welding speed (19 mm/min) because at lower welding speed material mixing is non-uniform. The distribution of hardness of weld produced using high welding speed on retreating side of the weld nugget is more uniform at higher welding speed than at lower welding speed. Lower hardness of thermo-mechanically affected zone than weld nugget can be due to the partial annealing effect and more work hardening effect in weld nugget zone.

The variation of the hardness from top to bottom at centre of weld nugget is shown in Fig. 8 (c). It can be seen that hardness of weld nugget (produced using both the welding speeds) at top is higher than bottom. The variation in hardness from top to bottom of the weld nugget can be attributed to variation in grain size and work hardening effects. Similar results were also reported by Won-Bae Lee during welding of copper plates [31]. Grain size of weld nugget is primarily determined by shape and tilt angle of tool which causes considerable microstructural refinement in the top region of the stir zone as compared to the centre and bottom region. The work piece material which is closest to the tool shoulder is subjected to

greater deformation compared to material away from the tool shoulder.

3.3 Tensile Properties

Average tensile properties of friction stir weld joints of commercial copper are given in Table IV. Engineering stress-strain diagram for as received and heat treated base metal and friction stir welded sample are shown in Fig. 9. Heat treatments of base metal decreases yield strength and ultimate tensile strength but increases ductility. Yield strength decreases from 240.7 MPa to 168.2 MPa while ultimate tensile strength decreases from 273.2 MPa to 239.3 Mpa. Ductility increases from 33.54 to 34.04%. FSW decreases yield strength and ultimate tensile strength significantly for weld producing lower welding speed (8 mm/min).

The yield strength decreases from 168.2 MPa to 93.8 MPa while ultimate tensile strength decreases from 239.3 MPa to 138.8 MPa. The tensile strength of weld joint produced using 19 mm/min welding speed was found higher than that of base material. At high welding speed the yield strength marginally decreases from 168.2 MPa to 165.4 MPa while ultimate tensile strength increases from 239.3 MPa to 256.9 MPa. Thus the maximum joint efficiency was found to be 107%.

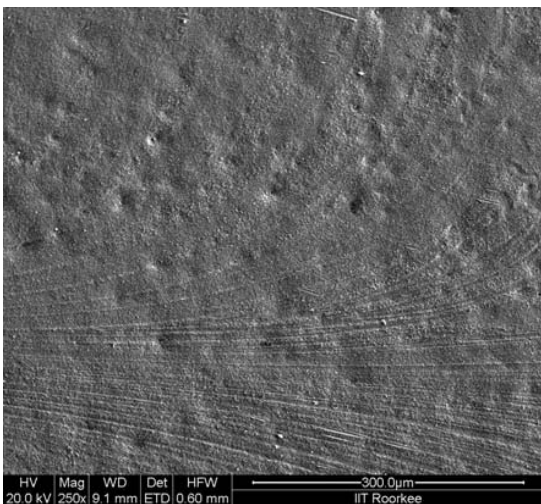

Fig. 7 SEM micrograph of weld nugget showing onion ring pattern

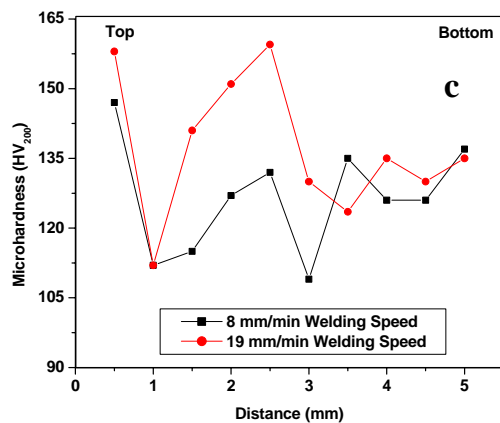
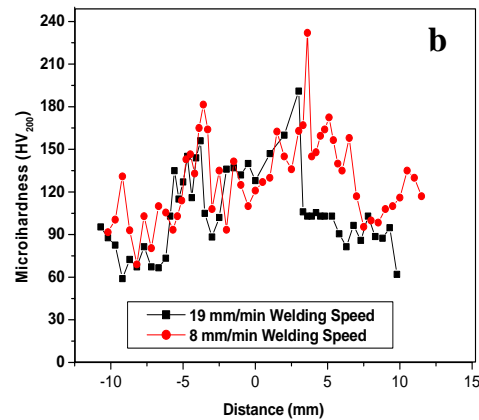
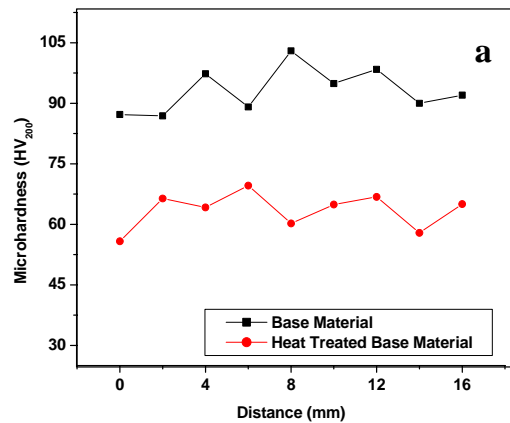

Fig. 8 Hardness, (a) Hardness of as received and heat treated base material (b) Hardness variation in across the weld nugget from weld centre (c) Hardness variation from to bottom of weld nugget at weld centre

It can be observed that increase in welding speed increases the tensile strength of the joint. Sundaram [32] found that low welding speed encourages the metallurgical transformations in the weld zone due to high heat input per unit length which lowers tensile strength of the friction stir welded joints.

The higher welding speeds are associated with low heat inputs and higher cooling rates of the welded joint. Reduced heat input decreases grain size and extent of unfavorable metallurgical transformations during welding (such as solutionization, re-precipitation and coarsening of precipitates); and hence, the local strength of individual regions across the weld zone is less affected. Ductility of weld joints was found to be lower than the base metal. Ductility of joint produced using 19 mm/min welding speed is found to be higher than that produced using 8 mm/min welding speed. Increase in the welding speed lowers the clustering effect of strengthening precipitates, plastic flow of materials and localization of strain. Low heat input results in improved tensile properties.

3.4 SEM Study Of Tensile Fracture Surfaces

Scanning electron microscopy was used to characterize the fracture surfaces of the tensile tested specimens to understand the mode of failure. SEM micrographs of tensile fractured surfaces invariably showed of dimples of varying size and shape, indicating that mode of fracture is ductile (Fig 10 a-d). In tensile testing of ductile materials; voids generally form after necking. However, if a neck occurs relatively earlier, then the void formation becomes much more prominent, coarse with elongated dimples. The fracture surface of as received base material shows coarse and elongated dimples while after heat treatment tensile fracture surface exhibited fine dimples (Fig. 10 a & b). The SEM micrographs of tensile fracture surfaces of weld joints produced using low welding speed showed river like pattern and flat fracture surface suggesting lower ductility & brittle fracture (Fig. 10 c) while that of weld joint produced using higher welding speed showed coarse and elongated dimples (Fig. 10 d). These observations are in agreement of mechanical properties (Table 5).

In weldments, the hardness of heat affected zone was the maximum; therefore the joint should fracture from lower hardness zones, i.e. thermo-mechanically affected zone, nugget and base metal if the joint is free from defect otherwise voids / cracks will be originated from the defect location causes failure.

IV. CONCLUSIONS

1. Weld nugget showed finer precipitates than the base metal in both as received and heat treated condition. Advancing side exhibited larger precipitates than the retreating side.

2. Hardness of base metal in as received condition was higher than that in heat treated conditions. Hardness in weld nugget was found higher than the base metal. The hardness in upper part of nugget at weld center is higher than that at the bottom side.

TABLE IV
TENSILE PROPERTIES OF AS-RECEIVED AND HEAT-TREATED BASE METAL AND WELD JOINT PRODUCED USING 8 AND 19 MM/MIN WELDING SPEEDS

Material Condition	Yield Strength (MPa)	Ultimate Tensile Strength (MPa)	% Elongation	E. Modulus (MPa)	Joint Efficiency (%)
As Received	240.7	273.2	33.54	9318	-
Heat Treated	168.2	239.3	34.04	8020	-
8 mm/min W.S.	93.8	138.8	5.51	9342	58.0
19 mm/min W.S.	165.4	256.9	24.44	9704	107.35

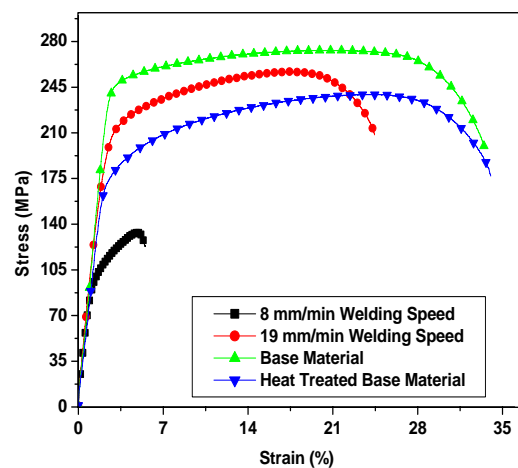

Fig. 9 Engineering stress-strain diagram of as-received and heat-treated base metal and weld joint produced using 8 and 19 mm/min welding speeds

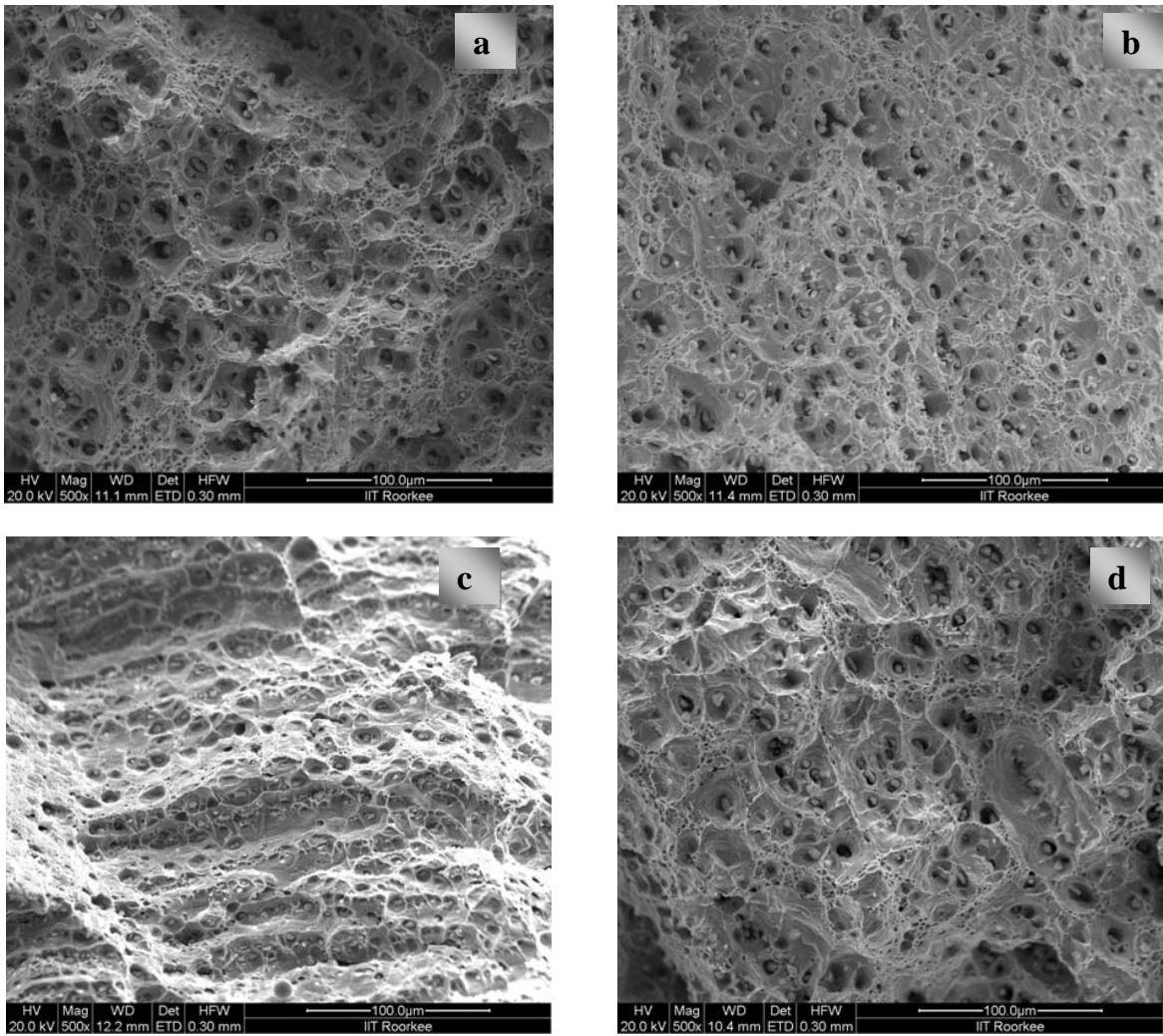





Fig. 10 Fracture surface of tensile test samples (a) as-received base metal, (b) heat-treated base metal, (c) tested sample produced using 8 mm/min welding speed and (d) tested sample produced using 19 mm/min welding speed

TABLE V
FRACTURE PROPERTIES OF AS-RECEIVED AND HEAT-TREATED BASE METAL AND WELD JOINT PRODUCED USING 8 AND 19 MM/MIN WELDING SPEEDS

Material Condition	Fracture Location	Fracture Characteristics	Fracture Mechanism	Tested Samples	
Base Metal	As Recived	-	Dimples	Microvoid coalescence	
	Heat Treated	-	Dimples	Microvoid coalescence	
Weld Joint	8 mm/min	Interference of NZ and TMAZ	River like pattern	Cleavage	
	19 mm/min	Base material	Dimples	Microvoid coalescence	

3. Tensile strength and ductility of joints produced using 19mm/min welding speed were found to be higher than that produced using 8mm/min welding speed.
4. Maximum joint efficiency was 107% in case of the weld produced using 19mm/min welding speed at 635 rpm.

Research Limitations/Implications

In this study, the limited FSW parameters were employed. Further studies are needed to evaluate the effects of welding parameters on the joining properties to establish the optimal weld parameters.

ACKNOWLEDGMENT

Authors are grateful to DST, GOI, India for providing financial support for carrying out this work vide sanction No. SR/S3/MERC/005/2009.

REFERENCES

- [1] W.M.Thomas, E.D.Nicholas, J.C.Needham, M.G Murch, S.P.Temple, C.J.Dawes, Improvements relating to friction welding. G. B. Patent No. 9125978. 8; (1991).
- [2] W.M.Thomas, E.D.Nicholas, Friction stir welding for the transportation industries. *Mater Des* (1997), 18(4-6):pp.269–73.
- [3] C.G. Rhodes, M.W. Mahoney, W.H. Bingel, R.A .Spurling, C.C. Bampton, Effects of friction stir welding on microstructure of 7075 aluminum. *Scripta Mater* (1997), 36(1): pp.69–75.
- [4] M.W.Mahoney, C.G.Rhodes, J.G.Flintoff, W. H.Bingel, R.A.Spurling, Properties of FSW 7075 T651 Aluminum, *Metall. Mater. Trans. A*, 29, (1998) pp.1955–1964.
- [5] G. Biallas, G. Braun, C.D. Donne, G. Staniek, W. Kaysser, Mechanical properties and corrosion behaviour of friction stir welded 2024-T4, Proceedings of the 1st International Symposium “Friction Stir Welding”, TWI, (1999), CD-ROM.
- [6] J. Adamowski, M. Szkodo, Friction Stir Welds (FSW) of aluminium alloy AW6082-T6, *Journal of Achievements in Materials and Manufacturing Engineering* 20 (2007), pp.403-406.
- [7] M. Vural, A. Ogur, G. Cam, C. Ozarpa, On the friction stir welding of aluminium alloys EN AW 2024-0 and EN AW 5754-H22, *Archives of Materials Science and Engineering* 28/1 (2007), pp.49-54.
- [8] P. Cavaliere, F. Panella, Effect of tool position on the fatigue properties of dissimilar 2024-7075 sheets joined by friction stir welding, *Journal of Materials Processing Technology* 206 (2008), pp.249-255.
- [9] A. Barcellona, G. Buffa, L. Fratini, D. Palmeri, On microstructural phenomena occurring in friction stir welding of aluminium alloys, *Journal of Materials Processing Technology* 177 (2006), pp.340-343.
- [10] S.T. Amancio-Filho, S. Sheikhi, J.F. dos Santos, C. Bolfarini, Preliminary study on the microstructure and mechanical properties of dissimilar friction stir welds in aircraft aluminium alloys 2024-T351 and 6056-T4, *Journal of Materials Processing Technology* 206 (2008), pp.132-142.
- [11] J.A. Esparza, W.C. Davis, E.A. Trillo, L.E. Murr, Friction-stir welding of magnesium alloy AZ31B, *Journal of Materials Science Letters* 21 (2002), pp.917-920.
- [12] B.M. Darras, M.K. Khraisheh, F.K. Abu-Farha, M.A. Omar, Friction stir processing of commercial AZ31 magnesium alloy, *Journal of Materials Processing Technology* 191 (2007), pp.77-81.
- [13] T.J. Lienert, W.L. Stellwag, B.B. Grimmer, R.W. Warke, Friction Stir Welding Studies on Mild Steel, *Welding Journal, Research Supplement* 82/1 (2003) pp.1-9.
- [14] A.P. Reynolds, W. Tang, T. Gnaupel-Herold, H. Prask, Structure, properties, and residual stress of 304L stainless steel friction stir welds, *Scripta Materialia* 48 (2003), pp.1289-1294.
- [15] H. Uzun, C.D. Donne, A. Argagnotto, T. Ghidini, C. Gambaro, Friction stir welding of dissimilar Al 6013-T4 To X5CrNi18-10 stainless steel, *Materials and Design* 26 (2005), pp.41-46.
- [16] K. Kimapong, T. Watanabe, Friction Stir Welding of aluminum alloy to steel, *Welding Journal* 83/10 (2004), pp.277-282.
- [17] J. Ouyang, E. Yarrapareddy, R. Kovacevic, Microstructural evolution in the friction stir welded 6061aluminum alloy (T6-temper condition) to copper, *Journal of Materials Processing Technology* 172 (2006), pp.110-122.
- [18] A.C. Somasekharan, L.E. Murr, Microstructures in friction-stir welded dissimilar magnesium alloys and magnesium alloys to 6061-T6 aluminum alloy, *Materials Characterization* 52 (2004), pp.49-64.
- [19] W.B. Lee, S.B. Jung, The joint properties of copper by friction stir welding, *Materials Letters* 58 (2004), pp.1041-1046.
- [20] G.M. Xie, Z.Y. Maa, L. Geng, Development of a fine-grained microstructure and the properties of a nugget zone in friction stir welded pure copper, *Scripta Materialia* 57 (2007), pp.73-76.
- [21] T. Sakthivel, J. Mukhopadhyay, Microstructure and mechanical properties of friction stir welded copper, *Journal of Materials Science* 42 (2007), pp.8126-8129.
- [22] H.S. Park, T. Kimura, T. Murakamic, Y. Naganod, K. Nakata, M. Ushio, Microstructures and mechanical properties of friction stir welds of 60% Cu–40% Zn copper alloy, *Materials Science and Engineering A* 371 (2004), pp.160-169.
- [23] C. Meran, The joint properties of brass plates by friction stir welding, *Materials and Design* 27 (2006), pp.719-726.
- [24] ASM Handbook, vol.6-CD, Welding, Brazing, and Soldering, USA, 1993, pp.1872-1876.
- [25] C.G. Andersson, R.E. Andrews, B.G.I. Dance, M.J. Russell, E.J. Olden, R.M. Samderson, A comparison of copper canister fabrication by the electron beam and friction stir processes, Proceedings of the 2nd International Symposium “Friction Stir Welding”, Gothenburg, 2000, CD-ROM.
- [26] Z. Barlas, H. Uzun, Microstructure and mechanical properties of friction stir butt welded dissimilar Cu/CuZn30 sheets, *Journal of Achievements in Materials and Manufacturing Engineering VOLUME 30, ISSUE 2, October 2008*, pp.182-186.
- [27] C.G. Andersson, R.E. Andrews, Proceedings of the First International Symposium on Friction Stir Welding, Thousand Oaks, California (1999).
- [28] K. Okamoto, M. Doi, S. Hirano, K. Aota, H. Okamura, Y. Aono, T.C. Ping, Proceedings of the Third International Symposium on Friction Stir Welding, Kobe, Japan (2001).
- [29] Mukhopadhyay J, Sengar GS, Sakthivel T, Microstructure and mechanical properties of friction stir weldedcopper, *J Mater Sci* (2007) 42:8126–8129 (2006) TMS 2006:103.
- [30] K.Colligan, Material Flow Behavior during Friction Stir Welding of Aluminum, *Welding Research Supplement*, (1999), pp.229-237.
- [31] Won-Bae Lee, Seung-Boo Jung, The joint properties of copper by friction stir welding, *Materials Letters* 58 (2004), pp.1041– 1046.
- [32] N. Shanmuga Sundaram, N. Murugan, Tensile behavior of Dissimilar Friction Stir Welds of aluminium allos, *Materials and Design* 31 (2010), pp.4184-4193.