

# Dynamic Control Modeling and Simulation of a UPFC-SMES Compensator in Power Systems

K. Saravanan, R. Anita

**Abstract**—Flexible AC Transmission Systems (FACTS) is granting a new group of advanced power electronic devices emerging for enhancement of the power system performance. Unified Power Flow Controller (UPFC) is a recent version of FACTS devices for power system applications. The back-up energy supply system incorporated with UPFC is providing a complete control of real and reactive power at the same time and hence is competent to improve the performance of an electrical power system. In this article, backup energy supply unit such as superconducting magnetic energy storage (SMES) is integrated with UPFC. In addition, comparative exploration of UPFC–battery, UPFC–UC and UPFC–SMES performance is evaluated through the vibrant simulation by using MATLAB/Simulink software.

**Keywords**—Power system, FACTS, UPFC, DC-DC chopper, battery, UC, SMES.

## I. INTRODUCTION

THE FACTS technology improves the performance of an electrical network with organization of real and reactive power control. FACTS components, particularly responsible for power quality problems such as voltage flicker, power loss and transient stability problems. These problems can be mitigated by sufficient power flow control. The main responsibility of power flow controllers is compensating line voltage and load support. UPFC has attained the classic recognition of the numerous FACTS devices. UPFC embraces with two FACTS devices through DC link capacitor, it's capable of performing series compensation, voltage and phase angle control simultaneously, guide to control of real and reactive power [1]-[4]. DC link capacitor energy storage is unable to supply controllable active power for an extended duration due to its inadequate energy storage [5], [6]. This DC link capacitor cannot compensate converter losses for the period of large transients [7]. Though the DC link capacitor energy storage is limited to a definite value, the backup energy storage systems have been introduced to store more energy. This backup energy storage system is used to improve the dynamic performance of power systems.

Energy storage systems (ESS) will be classified according to their applications such as short term responses and long term responses. Flywheels, superconducting coils and capacitor technologies correspond to short term response. These technologies are able to absorb and supply energy for

short duration (few seconds to minutes) with high power density. In general, it is used to improve power quality and voltage stability. ESS likes batteries, fuel cells and compressed air belong to long term response; they can provide potential to act in response for long time periods (few minutes to hours). These devices perform power systems applications like power grid management, energy management and frequency regulation [8].

A Battery energy storage system (BESS) typically has high energy density; however, it has a limited life cycle, discharge rates and high temperature at functional environment. A UC energy storage system classically has rapid responses, high power density and extended life cycle [9]. SMES unit has the rewards of rapid responses, minimum energy loss during the conversion, high energy density and high efficiency evaluated with other backup energy storage systems. ESS with the FACTS integrated system operates as the best solution for improving the power quality [10]-[15].

This research article discusses the comparative investigation of UPFC-battery, UPFC-UC and UPFC-SMES using MATLAB/Simulink software. The main intention of this work is to control a UPFC with energy storage devices under three phase fault conditions for the power system stability enrichment. This research article is ordered as follows. Section II contains a system description deals with operation of UPFC, ESS and chopper. Section III explains control strategies for UPFC-battery/UC/SMES integrated systems in detail. The simulation results are demonstrated in Section IV. Finally integrated system is concluded with Section V.

## II. SYSTEM DESCRIPTION

The system model of UPFC integrated with energy storage systems is shown in Fig. 1. In this model UPFC with energy storage systems is connected to the long transmission line. System model contains four main components such as UPFC, ESS, DC-DC chopper and controller. An ESS (Battery/UC/SMES) is allied to the UPFC through DC-DC chopper interface. The detail model of controller is described in Fig. 3. However, UPFC-ESS integrated systems proffer a better dynamic performance than a standalone UPFC. The rapid and autonomous control of both real and reactive power of UPFC -ESS system formulates it the ultimate aspirant for several applications in the electrical power systems.

K. Saravanan with Department of Electrical and Electronics Engineering, Paavai College of Engineering, Namakkal, Tamil Nadu, India (phone: +91-9003742853; e-mail: saravanan.me07@gmail.com).

Dr. R. Anita with Department of Electrical and Electronics Engineering, IRTT, Erode, Tamil Nadu, India (e-mail: anita\_irtt@yahoo.co.in).

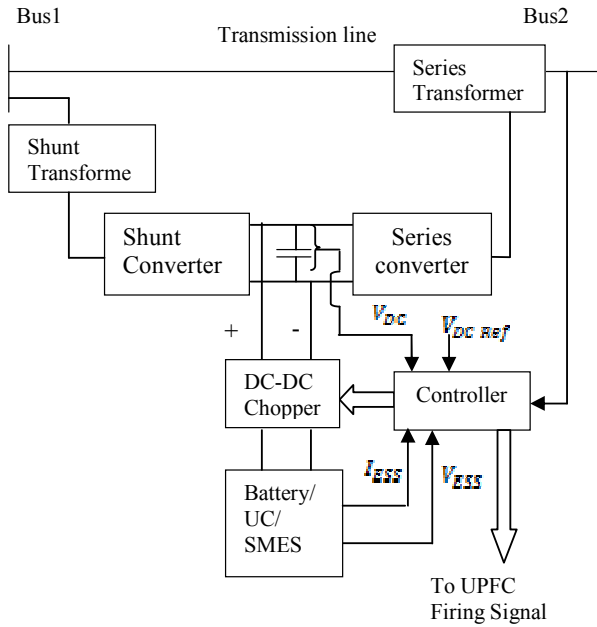

Fig. 1 System model

#### A. UPFC Operation

An UPFC circuit consists of a boosting transformer, excitation transformer, two voltage source converters (VSC1 & VSC2) and a DC link capacitor. VSC1 (Shunt converter) connected to a transmission line in parallel through boosting transformer and VSC2 (Series converter) coupled with excitation transformer in the transmission power network. These VSC1&VSC2 converters are coupled to each other with a common DC link capacitor. This DC bus permits the bidirectional flow of real power between terminals of SSSC and STATCOM. Shunt and series converters independently exchange reactive power with transmission power line. The VSC1 is primarily used for providing real power demand of the series converter through common DC link terminals. It can generate or absorb reactive power at its AC terminal, which is autonomous of the active power transfer to (or from) the DC terminal. The series connected inverter injects a voltage by means of controllable magnitude and phase angle in series with transmission line, thus providing real and reactive power to the transmission line. The combined version of real and reactive power provides the total complex power of the line. Real power can be calculated by line current in phase with injected voltage and reactive power is calculated by line current quadrature phase with injected voltage. The complex power of line it will be expressed as (1),

$$P - jQ = V_i \left( \frac{V_i + V_{se} - V_j}{jX} \right) \quad (1)$$

where  $i = \text{bus1}$  and  $j = \text{bus2}$ . The UPFC active and reactive power equations expressed as follows in (2) and (3),

$$P = \frac{V_i V_j}{X} \sin \delta + \frac{V_{se} V_j}{X} \sin(\delta + \rho) \quad (2)$$

$$Q = \frac{V_i V_j}{X} (\cos \delta - 1) + \frac{V_{se} V_j}{X} \cos(\delta + \rho) \quad (3)$$

It can be seen from (2) and (3) that when  $\rho = 90^\circ - \delta$ , transmission power line with UPFC will acquire the ultimate power. Introduce some suitable alteration of (2) and (3); it can acquire the real and reactive power expressed as in (4).

$$\left( P - \frac{V_i V_j}{X} \sin \delta \right)^2 + \left( Q - \frac{V_i V_j}{X} (\cos \delta - 1) \right)^2 = \left( \frac{V_{se} V_j}{X} \right)^2 \quad (4)$$

#### B. Energy Storage Devices

Energy storage devices such as a battery, UC and SMES have widely been adopted in UPFC due to their characteristics in terms of speedy response, power density, energy density, reliability and compact size. A battery is an electrochemical energy storage unit; it consists of two electrodes estranged by an electrolyte. Batteries applicable for power system applications are lead-acid, sodium-sulfur, nickel-cadmium, metal air, fluid flow, and lithium-ion. Amongst varieties of batteries, lead-acid battery is an old and mature technique for greater part of power system applications [16]. Lead-acid rechargeable battery is having a very low energy-to-weight ratio, low energy-to-volume ratio and low cost. These features attractive for use in power system applications.

Ultra capacitors having high energy storage capability compared to conventional capacitor due to its large surface area and thin dielectric between the electrodes. The UC capacitance ( $C_{UC}$ ) based on large surface areas of each electrode (A) and small distance between the electrodes (D) described as in (5):

$$C_{UC} = \epsilon_0 \epsilon_r \frac{A}{D} \quad (5)$$

where  $\epsilon_0$  the permittivity of free space and  $\epsilon_r$  is the permittivity of dielectric material. An electrical energy stored in the UC ( $E_{UC}$ ) is directly proportional to its capacitance  $C_{UC}$  and applied DC voltage  $V_{UC}$  as in (6).

$$E_{UC} = \frac{1}{2} C_{UC} V_{UC}^2 \quad (6)$$

The maximum power of UC is denoted as

$$P_{max} = \frac{V_{UC}^2}{4R} \quad (7)$$

where R is equivalent resistance. Maximum power of UC is inversely proportional to equivalent resistance of UC as in (7).

SMES is a direct current unit which stores electromagnetic energy for an extended duration directly without any loss of energy. In chopper power conditioning system, power flow takes place between the transmission power networks and the superconducting coil. The electromagnetic energy stored in the coil is given in (8):

$$E_{SMES} = \frac{1}{2} L_{SMES} I_{SMES}^2 \quad (8)$$

SMES rated power is given by (9):

$$P_{SMES} = \frac{dE_{SMES}}{dt} = L_{SMES} I_{SMES} \frac{dI_{SMES}}{dt} = V_{SMES} I_{SMES} \quad (9)$$

A battery/UC/SMES are connected to the DC side of a UPFC device through a chopper as in Fig. 1. Since UPFC devices frequently generate and absorb reactive power, the ESS device provides stored energy to UPFC when it's necessary of real power. The conventional UPFC has only two functional modes: lagging (inductive) mode and leading (capacitive) mode. Although every mode of existing UPFC output voltage magnitude and phase angle will be controlled, they cannot be modified in steady state because of the deficiency in the immense active power proficiency of UPFC. In case of UPFC-ESS, the functional modes are increased to four. These functional modes are explicitly, inductive with DC charging and discharging mode, capacitive with DC charging and discharging mode. Owing to the characteristic of ESS, the UPFC with ESS cannot be activated considerably in one of the four modes because of the energy storage device charge/discharge cycle; consequently, these modes represent a transient-state operation.

C. DC-DC Chopper Operation

The insertion of an ESS in the DC link capacitor of the UPFC requires the use of an interface to adjust the voltage and current levels of UPFC and ESS. In the case of using Battery, UC and SMES, a two quadrant DC-DC chopper act as an interface is shown in Fig. 2. By making small adjustments on the DC voltage by means of the chopper, independent control of active and reactive power exchange between the UPFC-battery/UC/SMES and the utility system will be achieved.

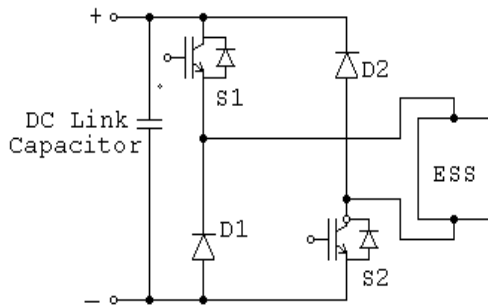

Fig. 2 Two quadrants DC-DC Chopper

ESS device has three modes of operation such as charging mode, standby mode and discharging mode. In charging mode, ESS device is charging when huge capability of load is detached from the transmission power line. At that time of detachment of the load enormous amount of power flows in the transmission power network. That power is absorbed from the power network by ESS. When the ESS unit is charging, the voltage across an ESS ( $V_{ESS}$ ) is positive and the relation between  $V_{ESS}$  and also the voltage across the dc link capacitor ( $V_{DC}$ ) is often given as in (10):

$$V_{ESS} = D * V_{DC} \quad (10)$$

Second mode stores energy in standby mode, when power systems are unbiased situations. In the third mode, ESS unit is discharging when loads are added to the power network or after the disturbance. For the duration of additional loads, require more power injections to transmission power networks from the discharging of ESS. When the ESS unit is discharging,  $V_{ESS}$  is negative and the relation between  $V_{ESS}$  and also  $V_{DC}$  is often given as in (11).

$$-V_{ESS} = (1 - D) * V_{DC} \quad (11)$$

The DC-DC chopper can be worked with an incessant spectrum of duty cycle (D) values ranging from 0 to 1. The voltage in the DC link capacitor is associated with the output voltage of the series and shunt converters of the UPFC/ESS system through (12),

$$V_{DC} = K a V_{inv} \quad (12)$$

where Ka is a constant linked with both the pulse-number of the VSCs (constant k) and the voltage ratio (a) of the transformers.

III. CONTROL APPROACH FOR UPFC-SMES/UC INTEGRATED SYSTEM

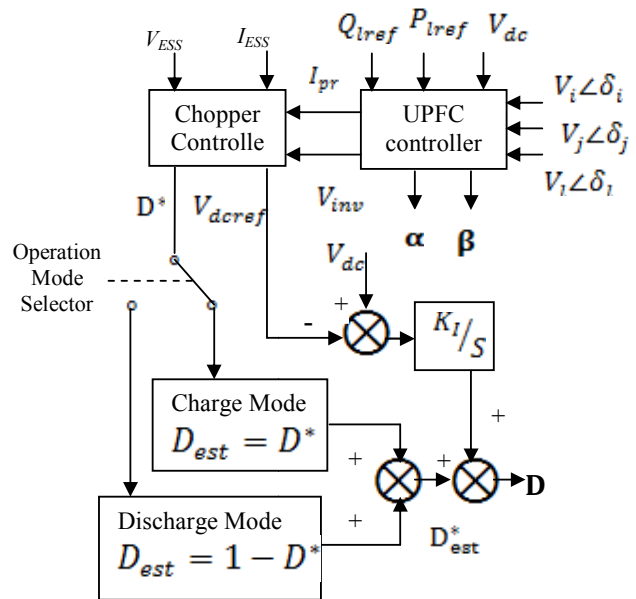

Fig. 3 Internal Controller of the UPFC and DC-DC Chopper

In general UPFC- Battery/UC/SMES has two control stages such as external loop control and internal loop control. In reference to power system necessities, an external loop controller offers real and reactive power instructions to the internal loop controller. Consequently, the internal loop controller generates firing control for the chopper circuit and different IGBTs of the VSC1&VSC2 of the UPFC. A

functional design of the internal control of the UPFC -ESS is shown in Fig. 3. The functional design that is proposed synchronizes the control subsystems of the DC-DC chopper and the VSCs of the UPFC. The control subsystem of VSCs has autonomous inputs of the reference signals of the current injected in line bus. From reference signals, the internal control resolves the magnitude and phase of the voltage at the VSCs of the UPFC respect to the voltage on the transmission power line. This internal loop control able to control two quadrant operations, based on the requirements of the external loop controller. The consequential signals  $D$ ,  $\alpha$  and  $\beta$  attained from the internal loop controller controls, DC-DC chopper, shunt converter and series converter respectively. As a result, Battery/UC/SMES device operation must be assured by the external loop control approach.

In this integrated systems an active power flow ( $P_{measured}$ ) through the DC bus is calculated and deducted from their reference value ( $P_{reference}$ ). This comparison results produce zero value for system normal condition as in (13). When the system deviates from its normal condition comparative results create the error signal ( $P_{error}$ ). Based on this  $P_{error}$  signal a DC-DC chopper circuit gate triggered. At the time of positive error signals as in (14) an ESS delivers power to UPFC through DC-DC chopper. An ESS store electrical energy as negative error signals occurred as in (15). The normal condition of the system

$$P_{reference} - P_{measured} = 0 \tag{13}$$

The abnormal condition of the system

$$P_{reference} - P_{measured} = P_{error}(positive) \tag{14}$$

$$P_{reference} - P_{measured} = P_{error}(negative) \tag{15}$$

#### IV. SIMULATION RESULT ANALYSIS

This research work presents the investigations of controlling a UPFC with ESS for the power quality improvement. UPFC integrated with ESS system is connected along the transmission line. A symmetrical three phase fault has been applied to the transmission line and the system dynamic performance is evaluated using MATLAB/SIMULINK software. Here the system transient is created on the bus at 1/60 s and it has been cleared in 6/60 s. Investigations are carried out with three topologies.

**Case (1):** UPFC with battery

**Case (2):** UPFC with UC

**Case (3):** UPFC with SMES

**Case (1)** is mentioned for the UPFC with the battery. Figs. 4-6 exhibits the dynamic response performance based on various parameters such as real power (P), reactive power (Q), and DC Voltage ( $V_{dc}$ ) for the UPFC-Battery system with PI controller. The simulation results show that significant damping is accomplished by means of using the PI controller.

**Case (2)** is mentioned for the UPFC with UC system. The transient responses are shown in Figs. 7-9.

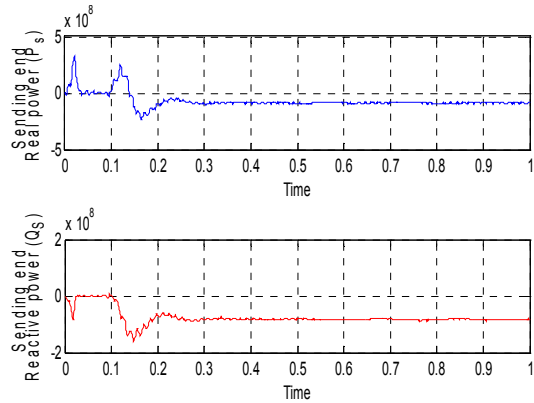

Fig. 4 Transmission line power at sending end of the UPFC-battery

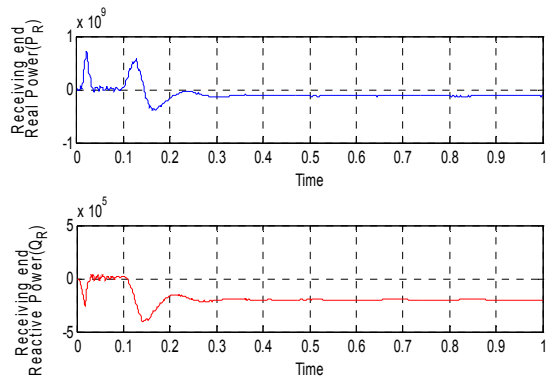

Fig. 5 Transmission line power at receiving end of the UPFC-battery

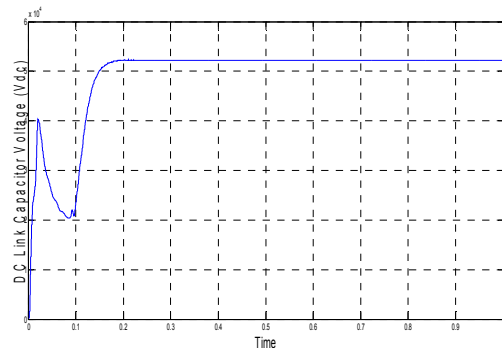

Fig. 6 DC link capacitor voltage of the UPFC-battery

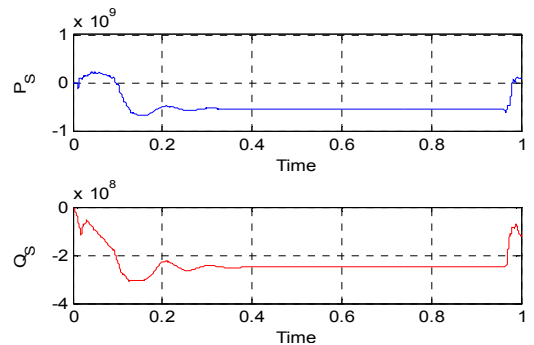

Fig. 7 Transmission line power at sending end of the UPFC-UC

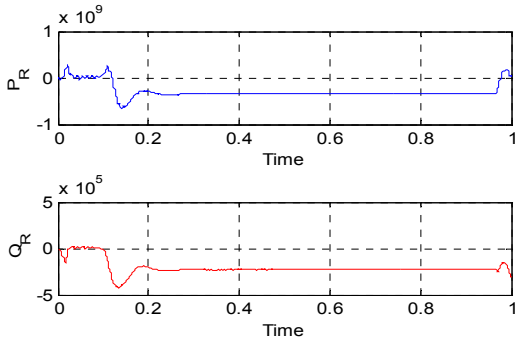

Fig. 8 Transmission line power at receiving end of the UPFC-UC

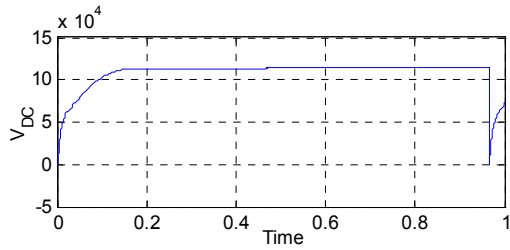

Fig. 9 DC link capacitor voltage of the UPFC-UC

**Case (3)** is mentioned for the UPFC with SMES system. The transient responses are shown in Figs. 10-12. The simulation results noticeably demonstrated that UPFC-SMES provides better damping of real power, reactive power and DC link voltage.

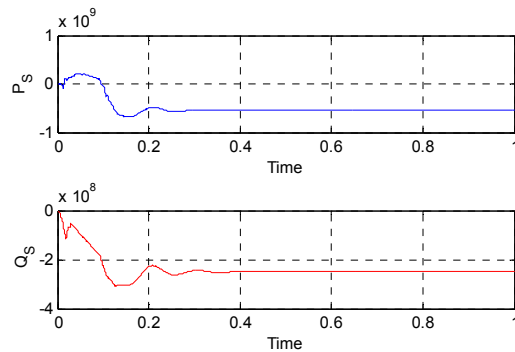

Fig. 10 Transmission line power at sending end of the UPFC-SMES

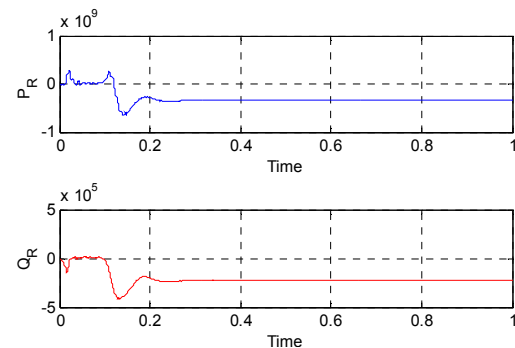

Fig. 11 Transmission line power at receiving end of the UPFC-SMES

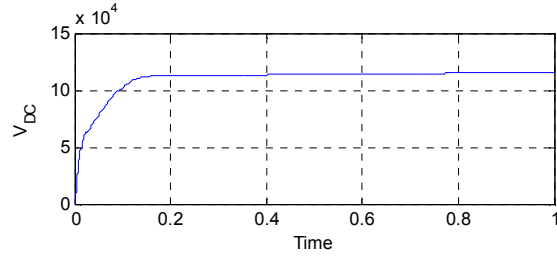

Fig. 12 DC link capacitor voltage of the UPFC-SMES

UPFC with ESS absorbs/supplies a real power flow path for UPFC; however UPFC controller is independent of backup supply. From the above results of three cases observed that the DC link capacitor voltage is preserved a constant and balance of active and reactive power after a fault cleared period. Backup energy sources are supporting active power and UPFC converters are supporting reactive power of load demand. An ESS does not support the reactive power load demand. The simulation results illustrated that the UPFC-Battery system provides low performance compared to UPFC-UC and UPFC-SMES systems because of its low power density. From the simulation results inferred that both UPFC-UC and UPFC-SMES systems have similar dynamic performance over a particular range. Subsequently UPFC-UC integrated system diverges from its actual values before the simulated time due to its lower energy density. So UPFC-SMES integrated system is capable of controlling and suggest a consistently terrific performance over a broad range of operating situations and disturbances.

V. CONCLUSION

The practicability of connecting the backup energy system to the UPFC is considered for power system performance improvement. The battery/UC/SMES with control of UPFC DC link capacitor voltage involves alteration of the chopper controller parameters to control the DC link capacitor voltage expedition. The chopper control is referred to using the utmost exploitation of the source active power and then permits the backup electrical energy storage systems to bear the active power required by the load. Among the three substantial energy storage systems, SMES based UPFC is much better than UC based UPFC and battery based UPFC schemes in terms of transient stability improvement, constant DC bus voltage and improved power transfer capability.

NOMENCLATURE

$V_i, V_j$	Voltage of $i^{th}$ and $j^{th}$ bus
$\delta_i, \delta_j$	Phase angle of voltages $V_i$ and $V_j$
$V_l$	Transmission line voltage
$\delta_l$	Phase angle of $V_l$
$V_{inv}$	UPFC inverter voltage
$V_{dc}$	UPFC dc-bus voltage
$V_{dcref}$	UPFC dc-bus reference voltage
$P_{lref}, Q_{lref}$	Active and reactive power reference in line

$I_{ESS}$	Current through energy storage system
$V_{ESS}$	Voltage across energy storage system
$P_S, Q_S$	Active and reactive power at sending end
$P_R, Q_R$	Active and reactive power at receiving end

## REFERENCES

- [1] L. Gyugyi, C. D. Schauder, S. L. Torgerson, and A. Edris, "The unified power flow controller: A new approach to power transmission control," *IEEE Transactions on Power Delivery*, vol. 10, no. 2, pp. 1085-1097, April 1995.
- [2] N. G. Hingorani, and L. Gyugyi, "Understanding FACTS concepts and technology of flexible AC transmission systems," *IEEE press*, 2000.
- [3] H. Shayeghi, H. A. Shayanfar, S. Jalilzadeh, and A. Safari, "Tuning of damping controller for UPFC using quantum particle swarm optimizer," *Energy Conversion and Management*, vol. 51, pp. 2299-306, 2010.
- [4] H. Shayeghi, H.A. Shayanfar, S. Jalilzadeh, and A. Safari, "Design of output feedback UPFC controller for damping of electromechanical oscillations using PSO," *Energy Conversion and Management*, vol. 50, no. 10, pp. 2554-2561, Oct. 2009.
- [5] F. Gharedaghi, M. Deysi, H. Jamali, and A. Khalili, "Investigation of energy storage devices impact on improvement of power quality aspects," *Research Journal of Applied Sciences, Engineering and Technology*, vol. 4, no. 6, pp. 571-580, March 2012.
- [6] A. Bidafar, M. Abedi M. Karari, C.C. Chu, "Power swings damping improvement by control of UPFC and SMES based on direct lyapunov method application," in *Proc. of IEEE Power Energy Soc. General Meeting*, pp. 1-7, 2008.
- [7] M. Zarghami, M. L. Crow, J. Sarangapani, Y. Liu, and S. Atcitty, "A novel approach to interarea oscillation damping by unified power flow controllers utilizing ultracapacitors," *IEEE Trans. on Power Systems*, vol. 25, no. 1, pp. 404-412, Feb. 2010.
- [8] A. Price, S. Bartley, S. Male, and G. Cooley, "A novel approach to utility scale energy storage," *Power Engineering Journal*, vol. 13, no. 3, pp. 122-129, June 1999.
- [9] S. C. Smith, P. K. Sen, and B. Kroposki, "Advancement of energy storage devices and applications in electrical power system," *IEEE Power and Energy Society General Meeting - Conversion and Delivery of Electrical Energy in the 21st Century*, pp.1-8.2008.
- [10] P. G. Therond, I. Joly, and M. Volker, 1993, "Superconducting magnetic energy storage (SMES) for industrial applications-comparison with battery systems," *IEEE Trans. on Applied Superconductivity*, Vol. 3, pp. 250-253, March 1993.
- [11] M. Parizh, A. K. Kalafala, and R. Wilcox, "Superconducting magnetic energy storage for substation applications," *IEEE Trans. Applied Superconductivity*, vol. 7, no. 2, pp. 849-852, June 1997.
- [12] C. A. Luongo, "Superconducting storage systems: an overview," *IEEE Trans. Magnetics*, vol. 32, no. 4, pp. 2214-2223, Jul. 1996.
- [13] A. B. Arsoy, Y. Liu, and P. F. Ribeiro, "Static synchronous compensators and superconducting magnetic energy storage systems in controlling power system dynamics," *IEEE Industry Applications Magazine*.2003.
- [14] M. G. Molina, and P. E. Mercado, "Comparative evaluation of performance of a STATCOM and SSSC both integrated with SMES for controlling the power system frequency," in *Proc. IEEE PES T&D LA.*, pp. 535-541, 2004.
- [15] S. Parmar hiren, K. Vamsi Krishna, R. Roy, and S. P. Ghoshal, "STATCOM-SMES system co-ordination in Controlling Power System Dynamic," *16th National Power Systems Conference*, pp.393-398.2010.
- [16] K. Alireza, and L. Zhihao, "Battery, ultracapacitor, fuel Cell, and hybrid energy storage systems for electric, hybrid electric, fuel cell, and plug-in hybrid electric vehicles: state of the art," *IEEE Trans. Veh Technol.*, vol. 59, pp. 2806-2814, July 2010.