

Detection of Max. Optical Gain by Erbium Doped Fiber Amplifier

Abdulamid.T. Bouzed, and Suleiman. M. Elhamali

Abstract—The technical realization of data transmission using glass fiber began after the development of diode laser in year 1962. The erbium doped fiber amplifiers (EDFA's) in high speed networks allow information to be transmitted over longer distances without using of signal amplification repeaters. These kinds of fibers are doped with erbium atoms which have energy levels in its atomic structure for amplifying light at 1550nm. When a carried signal wave at 1550nm enters the erbium fiber, the light stimulates the excited erbium atoms which pumped with laser beam at 980nm as additional light. The wavelength and intensity of the semiconductor lasers depend on the temperature of active zone and the injection current. The present paper shows the effect of the diode lasers temperature and injection current on the optical amplification. From the results of in- and output power one may calculate the max. optical gain by erbium doped fiber amplifier.

Keywords—Amplifier, erbium doped fiber, gain, lasers, temperature.

I. INTRODUCTION

THE first idea of sending the light signals by waveguide was presented in 1939 by Buchholz. The information transmissions using laser diode sand through glass fibers are the order of the day and the developments in this area belong to the most important ones in this century. In the fibers, light is conducted within a core diameter of only view micrometers. Further aims are the reduction in the transmission losses inside the fibers, optical amplifiers should reduce the number of electronic relays; and even laser diodes with smaller bandwidth that increase the transmission speed, to name a few.

The main reason for the replacement of the electronic with the optical amplifier lies therein that they can simultaneously amplify any data format and –rates within a comparatively extremely large spectral area. With that, the barrier of the small and limited bandwidth of electronic semiconductor amplifiers was broken. Out of the multitude of concepts for optical amplifiers, the Erbium doped fiber amplifier has turned out to be especially well suited. The fundamental principle of this new technology is the production of an amplifying medium through optical pumping. In glass fibers, the information transmission results through the temporal change in a flow of photons, whose count has to be likewise increased after a specific transport length.

This was done through the conversion of a stream of photons into a stream of electrons with the help of photodiodes

Abdulamid.T. Bouzed is with Plasma Laboratories, Tripoli, Libya (phone: 00218-92-5083520, fax: 00218-021-5634440, e-mail: a_bouzed@yahoo.com).

Suleiman.M. Elhamali, is with Plasma Laboratories, Tripoli, Libya. (e-mail: Suleiman_hamali@yahoo.co.uk).

with connected electronic amplification and the re-conversion of electrons into photons with laser diodes.

In optical amplifiers, however, this intermediate step is dropped; here the photon count is directly increased. The theory and practice of optical amplifiers is as old as the laser technique itself, since laser is nothing else but an optical amplifier that is increased as oscillation through feed-back. When one removes the feed-back in a Laser, one gets an optical amplifier which is in a position to amplify a stream of photons if its frequency lies within the amplification band width of the optical amplifier [1, 2, 3].

In this work the dependence of emission of laser diodes on the temperature and injection current will be presented. From the results of in- and output power we calculate the max. optical gain by erbium doped fiber amplifier.

II. EXPERIMENT SET UP

Fig. 1 shows the schematic diagram of the EDF experiment. The pump generated by a diode laser at wave length 980 nm. The pump power is varied by adjusting the laser diode injection current and changing the temperature. The signal is form a diode laser with its output emitted at wavelength 1550nm. Both laser beams (pump and signal) are fiber coupled and are coupled into the erbium doped fiber by a wavelength division multiplexer (WDM). Lens L1 was used to generate a parallel output beam at the exit of EDF. To block the pump beam the filter RG1000 was used and only filtered radiation can be transferred through the lens L2 into the InGaAs -photodetector [4, 5].

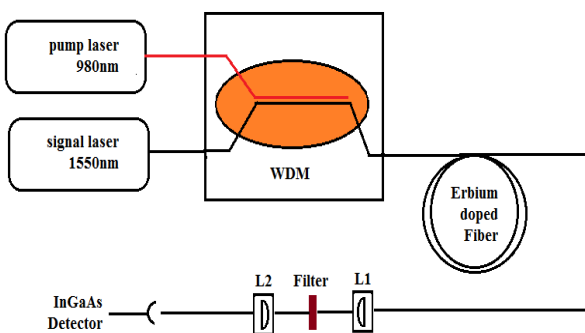

Fig. 1 Schematic diagram of the EDF experiment

17 m EDF length was used in this experiment with following data (see Table I).

TABLE I
DATA OF EDF [4]

| | | |
|---|---------------------|--------------|
| Core diameter | .22 | micrometer |
| Cladding diameter | 12.5 | micrometer |
| Refractive index difference between cladding and core | 30×10^{-3} | |
| NA | 0.3 | |
| Erbium concentration | 442 | ppm (weight) |
| Attenuation at 980 nm | 2.6 | dB/m |
| Attenuation at 1532 nm | 3.4 | dB/m |

III. RESULTS AND DISCUSSION

Many of semiconductor lasers illuminated in infrared region of the electromagnetic spectrum, a region of low transmission losses near the wavelength 1550 nm [3]. The wavelength of semiconductor lasers depends mainly on active zone temperature and injection current. The controls of both parameters occur on the wavelength, thus ensuring the quality of the transmission signals through the optical fiber.

The current injection and the temperature of active medium of semiconductor lasers occur changing in Laser wavelengths and thus the power of output beam. To identify experimentally the effect of the laser temperature on the output before determining the signal gain we conducted several measurements. The injection current of pump laser was fixed in each measurement only laser temperature was changed.

Fig. 2 and Fig. 3 show the relationship of injection current of signal laser and signal strength at fixed pump laser current 40 mA and difference laser temperatures 15 C° and 25 C° . The signal strength was increased at 15 C° than 25 C°.

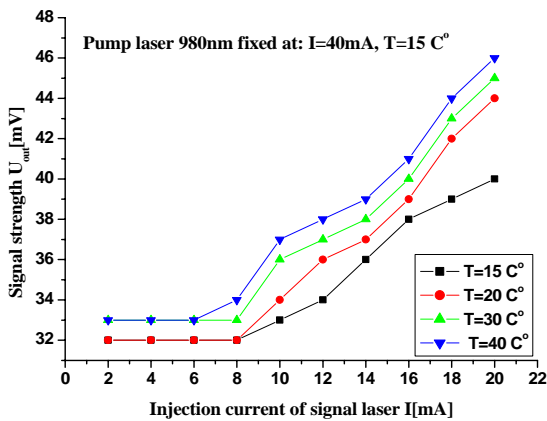

Fig. 2 Signal strength in mV versus the injection current in mA of signal laser 1550 nm by fixed I= 40 mA at T=15 C° of pump laser 980nm

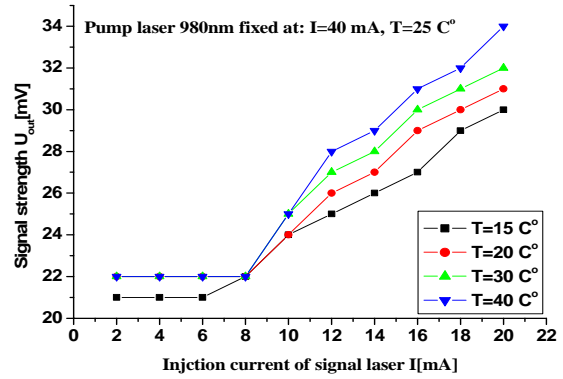

Fig. 3 Signal strength in mV versus the injection current in mA of signal laser 1550 nm by fixed I= 40 mA ant T=25 C° of pump laser 980nm

By other measurements with other injection current and temperatures we observed the same effect (see Fig. 4) and therefore we can say that the laser temperature affects the output power. Before we find amplification in the fiber, the temperature and injection current must be chosen so that they are suitable for higher amplification without any changing.

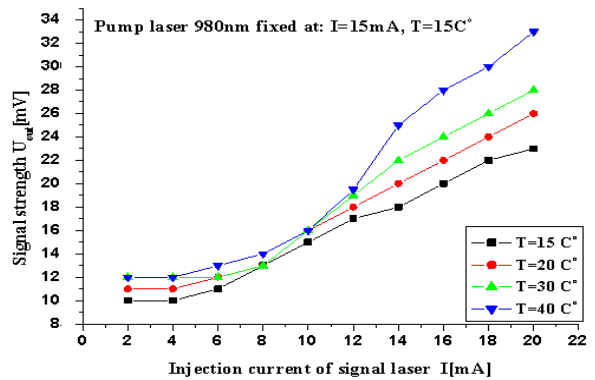

Fig. 4 Signal strength in mV versus the injection current in mA of signal laser 1550 nm by fixed I= 15 mA at T=15 C° of pump laser 980nm

The optical gain medium provides amplification by stimulated emission at 1550nm when pumped at 890nm.

From the plane wave model of an optical amplifier with a three level gain, the small signal gain of length can be expressed in:

$$G_0(\nu) = \exp[\gamma_0(\nu)l] \tag{1}$$

where $\gamma_0(\nu)$ is the small signal gain coefficient.

The gain of an amplifier in dB:

$$Gain (dB) = 10 \log_{10} G_0(\nu) = 10 \log_{10} e^{\gamma l} \tag{2}$$

At the output of fiber the signal power will be affected by pump power and amplified spontaneous emission

(AES).Based on simple approximation to measure the output power the gain of EDF can be written as the following [6,7]:

$$\text{Gain (dB)} = \frac{P_{out}}{P_{in}} \quad (3)$$

To obtain the max. gain for given erbium concentration in fiber core; the fiber length should be increased to the point at which the pump power becomes equal to the intrinsic pump threshold. In this experiment 17m of erbium fiber length was used. We avoid a high pump power and determinate the amplification for variable voltage and pump power. As signals only variable voltage are available which are linear to the respective signal strength at fiber output. The measurement is carried out with the modulated signal laser and only the respective amplitudes are measured.

The main objective of this paper was to find the max. gain by the used EDF. The injection current of the pump laser 980 nm was varied to produce the pump power. From the results of in-and output power we calculate the max. optical gain by erbium doped fiber amplifier using (3).

Fig. 5 shows the signal gain versus the absorbed pump power at 980 nm. The signal gain increases for signal power 0.05mW at 1550nm with increasing the absorbed pump power started from 6mW

In the region of 1 – 6 mW pump power the amplifications linearly follows in a good approximation of absorbed pump power.

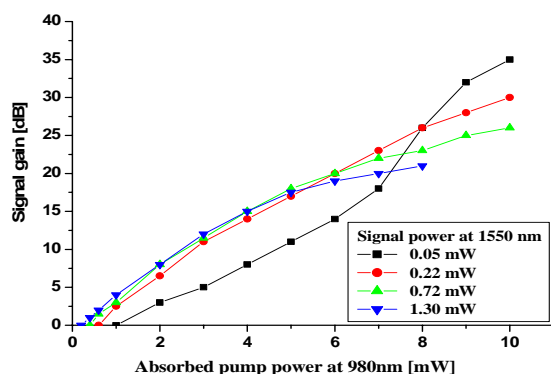

Fig. 5 Signal gain (in dB) at 1550 nm as a function of absorbed power at 980nm

IV. CONCLUSION

We have demonstrated that a laser temperature and injection current can effect on the output power. From the results of signal in- and output power we calculate the max. optical gain by erbium doped fiber amplifier. The max. signal gain of 17m length EDF was 36 dB by using pump power up to 8 mW and signal power 0.05 mW at 1550nm.

REFERENCES

- [1] Glen R. Elion and Herbert A. Elion, Marsel Dekker, Fiber optics communication system, Inc. New Yourk, 1978.
- [2] RobertJ. Hoss, Edward A. Lacy, Fiber Optics, Prentice Hall International, Inc, New Jersey, 1993.
- [3] H. J. Eichler und J. Eichler, Laser-High-Tech mitLicht, Springer Verlag 1995.
- [4] Klaus Dickmann, EDF, manual book, , MEOS, Muenster,Germany,1995.
- [5] B. S. Wang, M. J. Andrejco, Advanced topics on EDF for high performance amplifier, OFS, specialty photonics division, USA, 2004.
- [6] P. C. Becker, N. A. Olsson, J. R. Simpson, Erbium –Doped Fiber Amplifiers, Fundamentals and technology, academy press, San Diego,1999.
- [7] C. Hentschel, E. Leckel, complete analysis of erbium-doped fiber amplifiers, technical paper, Hewlett-Packard Co., 1995. G. O. Young, "Synthetic structure of industrial plastics (Book style with paper title and editor)." in Plastics, 2nd ed. vol. 3, J. Peters, Ed. New York: McGraw-Hill, 1964, pp. 15–64.