

Design of Digital IIR filters with the Advantages of Model Order Reduction Technique

K.Ramesh, A.Nirmalkumar, and G.Gurusamy

Abstract—In this paper, a new model order reduction phenomenon is introduced at the design stage of linear phase digital IIR filter. The complexity of a system can be reduced by adopting the model order reduction method in their design. In this paper a mixed method of model order reduction is proposed for linear IIR filter. The proposed method employs the advantages of factor division technique to derive the reduced order denominator polynomial and the reduced order numerator is obtained based on the resultant denominator polynomial. The order reduction technique is used to reduce the delay units at the design stage of IIR filter. The validity of the proposed method is illustrated with design example in frequency domain and stability is also examined with help of nyquist plot.

Keywords—Error index (J), Factor division method, IIR filter, Nyquist plot, Order reduction.

I.INTRODUCTION

An important step in the development of a digital filter is the determination of a realizable transfer function $G(z)$ approximating the given frequency response specifications. If an IIR filter is desired, it is also necessary to ensure that $G(z)$ is stable. The process of deriving the transfer function $G(z)$ is called digital filter design. After $G(z)$ has been obtained, the next step is to realize it in the form of a suitable filter structure. There are two major issues that need to be answered before one can develop the digital transfer function $G(z)$. The first and foremost issue is the development of a reasonable filter frequency response specification from the requirements of the overall system in which the digital filter is to be employed. The second issue is to determine whether an FIR or IIR filter is to be designed. The order reduction technique is then introduced to obtain an equivalent reduced IIR linear phase filter.

The mathematical models obtained from the theoretical criteria those relevant with the given system normally results as a higher order model. Such systems are difficult to be analyzed and also the design of controller becomes too difficult. Obviously, there is a need for smaller models. Smaller models are models that describe the behavior of a system accurately, without the disadvantage of unnecessary

detail. This enables the modeling of coupled complex phenomena in a reasonable time. First of all, these models should be smaller than the original model, meaning that they are computationally less demanding. Their behavior must in at least one way be comparable to the behavior of the original model. Preferably, the smaller models are physically as well as mathematically motivated. This makes the models interpretable and efficient. The host of mathematical processes to derive smaller models forms the field of what we call Model Order Reduction (MOR). The reason for the name is that the model is reduced in size by some technique. The model is assumed to be already present, being derived by physical laws and assumptions. Sometimes the methods are abusively called Reduced Order Modeling., which should then account for the task of modeling in such a way that the derived models are smaller right away.

In many cases it is very well possible to reduce the size of a model. We already saw that mathematical rules of discretization may lead to models which are too large and have too much detail for the required precision. Also the final output of the model has some flexibility in the required accuracy. In applications a small error is often admissible. This flexibility gives room for smaller approximations and faster methods. Furthermore, we are often only interested in certain states of the model, for instance only in the output due to a certain input. This, while the model contains information of inputs that are never imposed. Model Order Reduction tries to quickly capture the essential features of a structure. This means that in an early stage of the process, the most basic properties of the original model must already be present in the smaller approximation. At a certain moment the process of reduction is stopped. At that point all necessary properties of the original model must be captured with sufficient precision.

The order reduction of a linear time invariant system is applied in almost all fields of electrical engineering. The use of order reduced models for test simulations of complex systems is a lot easier than utilizing full order models. This is due to the fact that the lower order transfer function can be analyzed more easily. Therefore, order reduction algorithms are standard techniques in the integrated circuits community for analysis, approximation and simulation of models arising from interconnect and electromagnetic structure analysis.

Conventional reduction methods are available in literature for reducing the order of large-scale linear MIMO systems in frequency domain [1–4]. Some of the existing methods are based on the global properties of $G(s)$ have been proposed in the literature amongst which the frequency domain method using the continued-fraction expansion of $G(s)$ and the classical Pade approximations are well known for their computational simplicity and matching of few initial time-

K.Ramesh is Lecturer with the Department of Electrical and Electronics Engineering, Velalar College of Engineering and Technology, Erode, Tamilnadu, India-638012. (e-mail: myresearch2010@yahoo.com)

A.Nirmalkumar is Professor and Head with the Department of Electrical and Electronics Engineering, Bannari Amman institute of Technology, Sathyamangalam, Tamilnadu, India-638401.

G.Gurusamy is Dean with the Department of Electrical and Electronics Engineering, Bannari Amman institute of Technology, Sathyamangalam, Tamilnadu, India-638401.

moments. However, stability of such reduced-models is not guaranteed even though the original system is stable. Further, some mixed methods have been suggested by combining the algorithm of two different reduction methods [5–7]. In spite of having several reduction methods, none always gives the satisfactory results for all the systems.

In last decades, papers are came out in model order reduction based on concepts of dominant pole retention or dominant eigen value retention, Routh approximation, stability-equation method. An alternative approach suggested by a number of researchers is to use the methods belonging to the second category mentioned above to obtain better reduced-models and extend the applicability of the methods. In this connection the works of Shamash [8], Chen, et al [9], [10], Pal, et al [11] and Gupta, et al [12], are worth mentioning. S K Bhagat [13] proposed some new mixed methods for the simplification of single-input single-output systems of Stability preserving methods, such as, (g-d) canonical expansion.

In the proposed method, a mixed method is proposed for the reduction of linear phase digital IIR filters. The obtained filter transfer function as per given design specification is converted in to transfer function in 's' domain before let it in to model order reduction stage. The denominator polynomial of reduced order model is obtained by using the factor division method and numerator polynomial is obtained by proposed method. The reduced order model obtained by the proposed method will preserves the stability of the original system. The proposed method is explained in the following sections.

II. DIGITAL IIR FILTER SPECIFICATIONS

As in the case of an analog filter, either the magnitude and/or the phase (delay) response is specified for the design of a digital filter for most applications. In some situations, the unit sample response or the step response may be specified. In most practical applications, the problem of interest is the development of a realizable approximation to a given magnitude response specification. The phase response of the designed filter can be corrected by cascading it with an all pass section. In this paper, we restrict our attention to the magnitude approximation problem only.

In the case of IIR filter design, the most common practice is to convert the digital filter specifications in to analog low pass prototype filter specifications, to determine the analog low pass filter transfer function $H_a(s)$ meeting these specifications, and then to transform it into the desired digital filter transfer function $G(z)$. This approach has been widely used for many reasons such as the extensive tables are available, yields closed-form solutions and they are highly advanced.

The magnitude response specifications of a digital filter in the pass band and in the stop band are given with some acceptable tolerances. In addition, a transition band is specified between the pass band and the stop band to permit the magnitude to drop off smoothly.

Consider the low pass filter with the magnitude of $|G(e^{j\omega})|$, in the pass band defined by $0 \leq \omega \leq \omega_p$, we require that the magnitude approximates unity with an error $\pm\delta_p$, i.e.,

$$1 - \delta_p \leq |G(e^{j\omega})| \leq 1 + \delta_p, \quad \text{for } |\omega| \leq \omega_p \quad (1)$$

In the stop band, defined by $\omega_s \leq \omega \leq \pi$, we require that the magnitude approximates zero with an error of δ_s , i.e.,

$$|G(e^{j\omega})| \leq \delta_s, \quad \text{for } \omega_s \leq \omega \leq \pi. \quad (2)$$

The frequencies ω_p and ω_s are respectively called the pass band edge frequency and the stop band edge frequency. The limits of the tolerances in the pass band and stop band, δ_p and δ_s are usually called the peak ripple values. Note that the frequency response $G(e^{j\omega})$ of digital filter is an even function of ω . As a result, the digital filter specifications are given only for the range $0 \leq \omega \leq \pi$.

Digital filter specifications are often given in terms of the loss function, $A(\omega) = -20 \log_{10} |G(e^{j\omega})|$, in dB. Here the peak pass band ripple α_p and the minimum stop band attenuation α_s are given in dB, i.e., the loss specification of a digital filter are given by

$$\begin{aligned} \alpha_p &= -20 \log_{10} (1 - \delta_p) \text{ dB} \\ \alpha_s &= -20 \log_{10} (\delta_s) \text{ dB} \end{aligned} \quad (3)$$

The pass band and stop band edge frequencies, in most applications, are specified in Hz, along with the sampling rate of the digital filter. Since all filter design techniques are developed in terms of normalized angular frequencies ω_p and ω_s , the specified critical frequencies need to be normalized before a specific filter design algorithm can be applied. Let F_T , F_p and F_s denote respectively the sampling frequency, the pass band and stop band edge frequencies respectively.

$$\omega_p = \frac{\Omega_p}{F_T} = \frac{2\pi F_p}{F_T} \quad (4)$$

$$\omega_s = \frac{\Omega_s}{F_T} = \frac{2\pi F_s}{F_T} \quad (5)$$

For the design of an IIR digital low pass filter $G(z)$ based on the conversion of an analog low pass filter $H_a(s)$, the filter order of $H_a(s)$ is first estimated from its specifications. The order (n) of butter worth low pass filter is obtained from the equation

$$n = \frac{\log_{10}(1/k_1)}{\log_{10}(1/k)} \quad (6)$$

$$\text{Where, } k = \frac{\Omega_p}{\Omega_s} \text{ and } k_1 = \frac{\varepsilon}{\sqrt{A^2 - 1}}$$

The resultant IIR filter transfer function in 'Z' domain is used for reduction of IIR filter complexity.

III. STATEMENT OF PROBLEM

Consider an n^{th} order linear phase digital IIR filter denoted in Z domain as,

$$G(z) = \frac{X(z)}{Y(z)} = \frac{A_0 + A_1z + A_2z^2 + \dots + A_mz^m}{B_0 + B_1z + B_2z^2 + \dots + B_{n-1}z^{n-1} + B_nz^n} \quad (7)$$

While applying the proposed model order reduction technique, the linear transformation technique ($Z=S+1$) is applied to obtain the transfer function in 's' domain.

$$G(s) = \frac{N(s)}{D(s)} = \frac{a_0 + a_1s + a_2s^2 + \dots + a_ms^m}{b_0 + b_1s + b_2s^2 + \dots + b_{n-1}s^{n-1} + b_ns^n} \quad (8)$$

$$= \frac{\sum_{k=0}^m a_k s^k}{\sum_{k=0}^n b_k s^k}$$

where $a_k = [a_{ij}^k]_{pxq}$ $i=1, 2, \dots, p$
 $j=1, 2, \dots, q$
 $k=0, 1, 2, \dots, m$.
 and $b_k = a_{0,k}$ ($k=0, 1, 2, \dots, n-1$).

The corresponding r^{th} ($r < n$) order reduced order is of the form

$$Gr(s) = \frac{\overline{N(s)}}{D(s)} = \frac{d_0 + d_1s + d_2s^2 + \dots + d_{r-1}s^{r-1}}{e_0 + e_1s + e_2s^2 + \dots + e_{r-1}s^{r-1} + e_rs^r} \quad (9)$$

$$= \frac{\sum_{k=0}^{r-1} d_k s^k}{\sum_{k=0}^r e_k s^k}$$

where $d_k = [a_{ij}^k]_{pxq}$ $i=1, 2, \dots, p$
 $j=1, 2, \dots, q$
 $k=0, 1, 2, \dots, r-1$.

and e_k ($k=0, 1, 2, \dots, r-1, r$)

Inverse linear transformation ($s=z-1$) is then applied at equation (9) to form the reduced order linear phase IIR filter. In this paper, the obtained reduced model retains the important characteristics of the original digital IIR filter system and approximates its response as closely as possible for the same type of inputs.

IV. PROPOSED METHOD

The reduced order obtained by the proposed method consists of two steps. In first step, the reduced order denominator polynomial is obtained by using the method as described in [14]. The numerator polynomial is obtained

further in second step based on the resultant denominator polynomial.

Step 1

Obtaining the denominator polynomial from the given system transfer function

The n^{th} order original system given in equation (8) is equated to the r^{th} order reduced model represented by the equation (9)

$$\frac{a_0 + a_1s + a_2s^2 + \dots + a_{n-1}s^{n-1}}{b_0 + b_1s + b_2s^2 + \dots + b_{n-1}s^{n-1} + b_ns^n} = \frac{d_0 + d_1s + d_2s^2 + \dots + d_{r-1}s^{r-1}}{e_0 + e_1s + e_2s^2 + \dots + e_{r-1}s^{r-1} + e_rs^r} \quad (10)$$

On cross multiplying and rearranging the equation (10)

$$a_0e_0 + (a_0e_1 + a_1e_0)s + (a_0e_2 + a_1e_1 + a_2e_0)s^2 + \dots + a_{n-1}e_ks^{n-1+r} = b_0d_0 + (b_0d_1 + b_1d_0)s + \dots + b_nd_{r-1}s^{n-1+r} \quad (11)$$

By equating the coefficients of the same power of 's' on both sides in the equation and simplifying the relations, the reduced order denominator polynomial is obtained as,

$$D_r(s) = e_0 + e_1s + e_2s^2 + \dots + e_{r-1}s^{r-1} + e_rs^r \quad (12)$$

Step 2

Consider the given system transfer function given in (8)

$$G(s) = \frac{a_0 + a_1s + a_2s^2 + \dots + a_ms^m}{b_0 + b_1s + b_2s^2 + \dots + b_{n-1}s^{n-1} + b_ns^n} = K \frac{(1 + A_1s + A_2s^2 + \dots + A_ms^m)}{(1 + B_1s + B_2s^2 + \dots + B_{n-1}s^{n-1} + B_ns^n)} ; n \geq m \quad (13)$$

Where, $K = \frac{a_0}{b_0}$,

$A_i = \frac{a_i}{a_0}$; $i=0, 1, 2, 3 \dots m$ and

$B_j = \frac{b_j}{b_0}$; $j=0, 1, 2, 3 \dots n$

Let the transfer function of the approximating low-order system be,

$$Gr(s) = K \frac{(1 + C_1s + C_2s^2 + \dots + C_qs^q)}{(1 + D_1s + D_2s^2 + \dots + D_{p-1}s^{p-1} + D_ps^p)} \quad (14)$$

where $n \geq p \geq q$

The following relation should be satisfied as closely as possible

$$\frac{|G(j\omega)|^2}{|G_r(j\omega)|^2} = 1 \text{ for } 0 \leq \omega \leq \infty \quad (15)$$

$$\frac{G(s)}{G_r(s)} = \frac{(1+A_1s+A_2s^2+\dots+A_m s^m)(1+D_1s+D_2s^2+\dots+D_{p-1}s^{p-1}+D_p s^p)}{(1+B_1s+B_2s^2+\dots+B_{q-1}s^{q-1}+B_q s^q)(1+C_1s+C_2s^2+\dots+C_q s^q)} \quad (16)$$

$$= \frac{(1+m_1s+m_2s^2+\dots+m_u s^u)}{(1+l_1s+l_2s^2+\dots+l_{v-1}s^{v-1}+l_v s^v)}$$

Where, $u=m+p$ and $v=n+q$

$$\frac{|G(j\omega)|^2}{|G_r(j\omega)|^2} = \frac{G(s)G(-s)}{G_r(s)G_r(-s)} \Big|_{s=j\omega} \quad (17)$$

The equation produces the even powers of s^2 and can be written as,

$$\frac{|G(j\omega)|^2}{|G_r(j\omega)|^2} = \frac{1+L_2s^2+L_4s^4+\dots+L_{2u}s^{2u}}{1+M_2s^2+M_4s^4+\dots+M_{2v}s^{2v}} \Big|_{s=j\omega} \quad (18)$$

$$\frac{|G(j\omega)|^2}{|G_r(j\omega)|^2} = 1 + \frac{(L_2-M_2)s^2+(L_4-M_4)s^4+\dots+(L_{2u}-M_{2u})s^{2u}}{1+M_2s^2+M_4s^4+\dots+M_{2v}s^{2v}} \Big|_{s=j\omega} \quad (19)$$

To satisfy the above equation,

$$L_2 = M_2$$

$$L_4 = M_4$$

.

.

.

$$L_{2u} = M_{2v} \quad ; \text{ if } u=v \quad (20)$$

If $u < v$, then the error generated by the lower order model is,

$$|\varepsilon| = \frac{|G(j\omega)|^2}{|G_r(j\omega)|^2} - 1 \quad (21)$$

On comparing the equations (10) and (11), we get

$$L_{2x} = \sum_{i=0}^{x-1} (-1)^i 2m_i m_{2x-i} + (-1)^x m_x^2 \quad (22)$$

for $x=1, 2, 3, \dots, u$ and $m_0=1$

and

$$M_{2y} = \sum_{i=0}^{y-1} (-1)^i 2l_i l_{2y-i} + (-1)^y l_y^2 \quad (23)$$

for $y=1, 2, 3, \dots, v$ and $l_0=1$

From the equation (13), the reduced order model numerator coefficients can be obtained. Finally the reduced order model is in the form of

$$Gr(s) = K \frac{(1+C_1s+C_2s^2+\dots+C_q s^q)}{(1+D_1s+D_2s^2+\dots+D_{p-1}s^{p-1}+D_p s^p)} \quad (24)$$

V. DESIGN EXAMPLE

Consider the digital IIR filter with the transfer function in direct form as $H(z)$ in equation (25) and the general structure of lattice-ladder IIR filter is shown in fig.1.

$$H(z) = \frac{1+2z^{-1}+2z^{-2}+z^{-3}}{1+0.54167z^{-1}+0.625z^{-2}+0.333z^{-3}} \quad (25)$$

$$= \frac{z^3+2z^2+2z+1}{z^3+0.54167z^2+0.625z+0.333} \quad (26)$$

$$= 1 + \frac{1.45833z^2+1.375z+0.667}{z^3+0.54167z^2+0.625z+0.333} \quad (27)$$

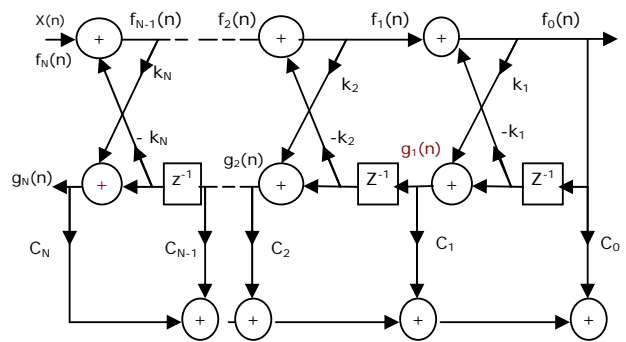

Fig.1 Structure of Lattice-ladder IIR filter oh N^{th} order

Let,

$$G(z) = \frac{1.45833z^2+1.375z+0.667}{z^3+0.54167z^2+0.625z+0.333} \quad (28)$$

By applying the linear transformation ($Z=S+1$), the transfer function $G(z)$ becomes $G(s)$ and is given by,

$$G(s) = \frac{1.45833s^2+4.29166s+3.50033}{s^3+3.54167s^2+4.70834s+2.49967} \quad (29)$$

By applying the step-1 as stated in the proposed method, the reduced order denominator polynomial is obtained as,

$$D_r(s) = 0.20499s^2+0.43244s+0.333 \quad (30)$$

With help of denominator polynomial $D_r(s)$, the numerator polynomial is obtained from the proposed method as,

$$N_r(s) = 0.2995s+0.467 \quad (31)$$

On applying inverse linear transfer function, the reduced order transfer function in 'z' domain is obtained as,

$$H_r(z) = \frac{0.205z^2 + 0.322z + 0.2731}{0.205z^2 + 0.02246z + 0.1056} \quad (32)$$

The results were compared in both continuous and as well as in discrete domain and are shown in fig.2 and fig.3 respectively. The error index (J) between the original and reduced order filter is obtained as 0.093.

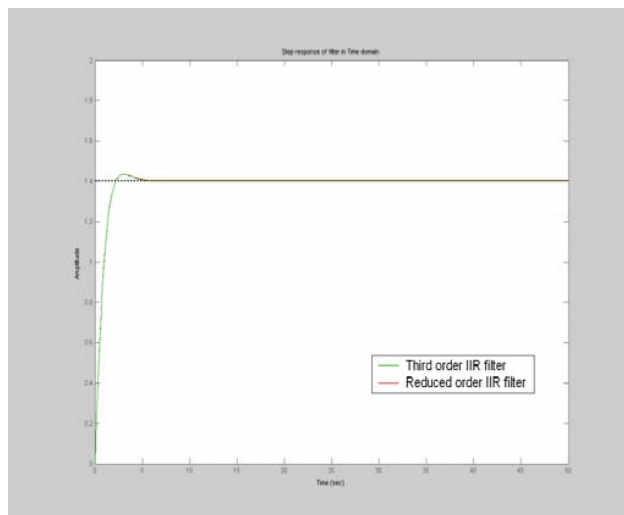

Fig.2 Comparison of Step responses

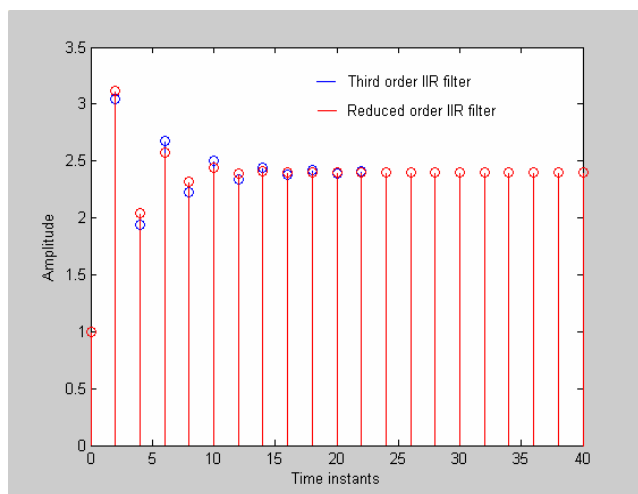

Fig.3 Comparison of original and reduced order IIR filters in discrete instants

The closeness of the higher order filter with reduced order IIR filter in frequency domain is shown in fig.4. The reduced order IIR filter preserves closeness with original IIR filter and also preserves the closed loop stability. The reduced order IIR filter has the poles at $-0.0548 + 0.7156i$ and $-0.0548 - 0.7156i$. There is no pole at right half of the s-plane and hence the reduced order system is stable. The stability criterion is hence proved with the help of Nyquist plot and is shown in fig.5.

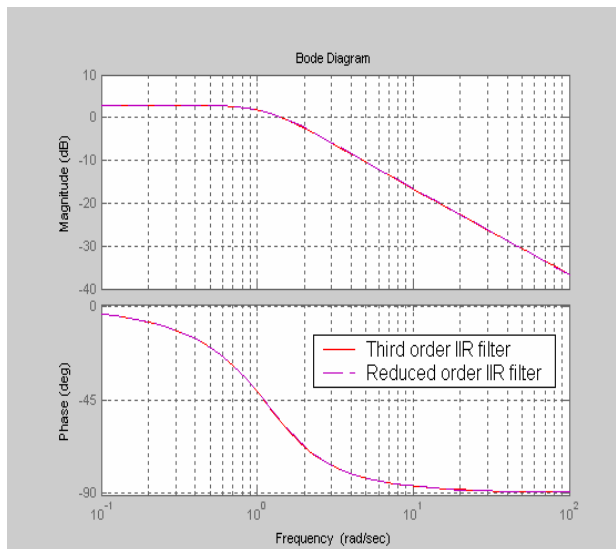

Fig.4 Frequency responses of original and reduced order IIR filters

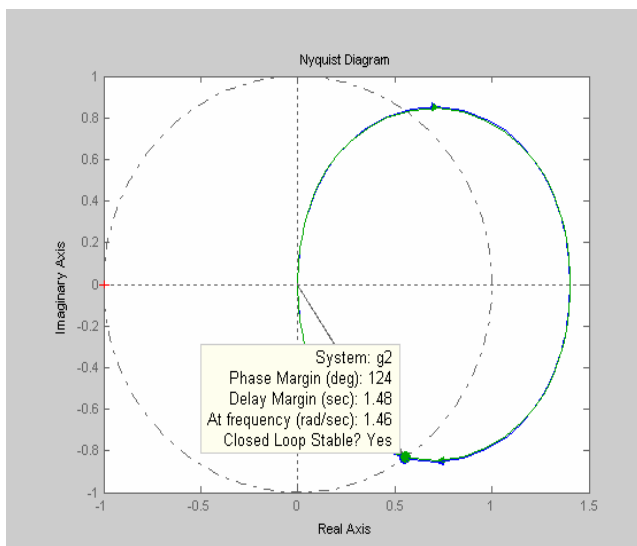

Fig.5 Nyquist plot of original and reduced order IIR filters

The reduced order transfer function $H_r(z)$ is also can be stated as,

$$H_r(z) = \frac{0.205 + 0.322 z^{-1} + 0.2731 z^{-2}}{0.205 + 0.02246 z^{-1} + 0.1056 z^{-2}} \quad (33)$$

The direct forms of reduced order IIR filter can be represented in reduced order Lattice-ladder IIR filter form some conversions. Consider the direct form of Lattice-ladder IIR filter in the form of

$$H_r(z) = \frac{b_M(z)}{a_n(z)} = \frac{0.205 + 0.322 z^{-1} + 0.2731 z^{-2}}{0.205 + 0.02246 z^{-1} + 0.1056 z^{-2}} \quad (34)$$

From the equation (34), the lattice-ladder filter co-efficient are obtained as $a_2(0) = 0.205$, $a_2(1) = 0.02246$, $a_2(2)=k_2=0.1056$, $b_2=0.205$, $b_1=0.322$ and $b_0=0.2731$. The co-efficient 'c' is obtained with the equation of,

$$C_m = b_m - \sum_{i=m+1}^M C_i a_i(i-m) \quad ; m=M, M-1, \dots, 0. \quad (35)$$

and

$$a_{m-1}(k) = \frac{a_m(k) - a_m(m)a_m(m-k)}{1 - a_m^2(m)} \quad (36)$$

The value of a parameter k_1 is obtained from the above equation as $k_1 = a_1(1) = 0.02$. The reduced order structure of lattice-ladder IIR filter is shown in fig.6.

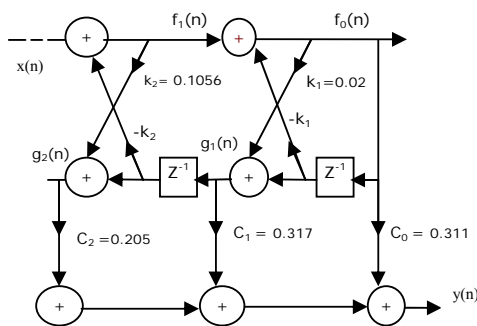

Fig.6 Structure of Reduced order Lattice-ladder IIR filter

VI. CONCLUSION

This paper proposes the novel model order reduction for the design of IIR filters. The reduced order model results in reduction in number of delay units and other components in the filter design stage. The reduced order model has closeness with respect to the higher order system in their performance characteristics. The proposed method is mathematically simple and also applied to the large scale systems with substantial merits over other conventional methods. The simulation results show the good approximation and stability criterion of the reduced order model.

REFERENCES

- [1] R. Prasad, J. Pal, and A. K. Pant, "Multivariable system approximation using polynomial derivatives," *Journal of the Institution of Engineers*, vol. 76, pp. 186–188, 1995.
- [2] Y. Bistritz and U. Shaked, "Minimal Pade model reduction for multivariable systems," *Journal of Dynamic Systems, Measurement and Control*, vol. 106, no. 4, pp. 293–299, 1984.
- [3] C. F. Chen, "Model reduction of multivariable control systems by means of matrix continued fractions," *International Journal of Control*, vol. 20, no. 2, pp. 225–238, 1974.
- [4] M. R. Calfe and M. Healey, "Continued fraction model reduction technique for multivariable systems," *Proceedings of the Institution of Electrical Engineers*, vol. 121, no. 5, pp. 393–395, 1974.
- [5] R. Prasad, "Pade type model order reduction for multivariable systems using routh approximation," *Computers & Electrical Engineering*, vol. 26, no. 6, pp. 445–459, 2000.

- [6] R. Prasad, A. K. Mittal, and S. P. Sharma, "A mixed method for the reduction of multi-variable systems," *Journal of the Institution of Engineers*, vol. 85, pp. 177–181, 2005.
- [7] L. Shieh and Y. Wei, "A mixed method for multivariable system reduction," *IEEE Transactions on Automatic Control*, vol. 20, no. 3, pp. 429–432, 1975.
- [8] Y. Shamash, "Model Reduction using the Routh Stability Criterion and the Pade Approximation Technique," *International Journal of Control*, vol. 21, no. 3, pp. 475–484, 1975.
- [9] T C Chen, C Y Chang, and K W Han, "Model Reduction using Stability equation Method and the Pade Approximation Method," *Journal of Franklin Institute*, vol. 309, 1980, pp 473-490.
- [10] T C Chen, C Y Chang, and K W Han, "Model Reduction using Stability equation Method and Continued Fraction Method," *International Journal of Control*, vol. 32, no. 1, 1980, pp 81-94.
- [11] J Pal, A K Sinha, and N K Sinha, "Reduced-order Modeling using Pole Clustering and Time-moment Matching," *Journal of The Institution of Engineers (India)*, Pt El, vol. 76, 1995, pp 1-6.
- [12] D K Gupta, S K Bhagat and J P Tewari, "A Mixed Method for the Simplification of Linear Dynamic Systems," in *Proceedings of International Conference on Computer Applications in Electrical Engineering Recent Advances*, IIT, Roorkee, February 21-23, 2002, pp 455-459.
- [13] S K Bhagat, J P Tewari and T Srinivasan, "Some Mixed Methods for the Simplification of High-order Single-input Single-output Systems," *IE (I) Journal.EL*, Vol. 85, pp.120-123, Sep 2004.
- [14] K.Ramesh, A.Nirmalkumar and G.Gurusamy, "Order reduction by error minimization technique," *Proceedings of International Conference on Computing, Communication and Networking 2008*, Dec 2008, pp 1-6.



Ramesh.K received B.E. degree in Electrical and Electronics Engineering from K.S.R.College of Technology, Tamilnadu, India in 2002 and M.E. in Applied Electronics from Kongu Engg. College, Anna University, Chennai in 2005 and also received the MBA in System from PRIDE, Salem (Tamilnadu), India in 2005. Since then, he is working as a Lecturer in Velalar College of Engineering and Technology (Tamilnadu), India. Presently he is a Part time (external) Research Scholar in the Department of Information and Communication at Anna University, Chennai (India). His fields of interests include Model order reduction, Controller design and Optimization Techniques.



Dr.Nirmalkumar.A. received the B.Sc.(Engg.) degree from NSS College of Engineering, Palakkad in 1972, M.Sc.(Engg.) degree from Kerala University in 1975 and completed his Ph.D. degree from PSG Tech in 1992. Currently, he is working as a Professor and Head of the Department of Electrical and Electronics Engineering in Bannari Amman Institute of Technology, Sathyamangalam, Tamilnadu, India. His fields of Interest are Power quality, Power drives and control and System

optimization.



Dr.G.Gurusamy obtained his Pre-University education at St Johns College, Palayamkottai, and Thirunelveli district. He then joined PSG College of Technology, Coimbatore, in the year 1962 to pursue his Engineering course. He was graduated in Electrical Engineering in 1967. He latter obtained M.E (Applied Electronics) in 1972 and Ph.D in Control Systems in 1983. He is currently working as a Dean of Department of Electrical and Electronics Engineering in Bannari Amman Institute of Technology, Sathyamangalam. His fields of Interest

are Advanced control, Digital control, Optimization and Biomedical electronics.