

Design of Controllers to Control Frequency for Distributed Generation

R. Satish, G. Raja Rao

Abstract—In this paper a hybrid distributed generation (DG) system connected to isolated load is studied. The DG system consisting of photo voltaic (PV) system, fuel cells, aqua electrolyzer, diesel engine generator and a battery energy storage system. The ambient temperature value of PV is taken as constant to make the output power of PV is directly proportional to the radiation and output power of other DG sources and frequency of the system is controlled by simple integral (I), proportional plus integral (PI), and proportional plus integral and derivative (PID) controllers. A maiden attempt is made to apply a more recent and powerful optimization technique named as bacterial foraging technique for optimization of controllers gains of the proposed hybrid DG system. The system responses with bacterial foraging based controllers are compared with that of classical method. Investigations reveal that bacterial foraging based controllers gives better responses than the classical method and also PID controller is best. Sensitivity analysis is carried out which demonstrates the robustness of the optimized gain values for system loading condition.

Keywords—Aqua electrolyzer, bacterial foraging, battery energy storage system, diesel engine generator, distributed generation, fuel cells, photo voltaic system.

I. INTRODUCTION

THE energy consumption rises with increasing demands and growth of developing nations, whereas fossil fuel resources decline at an equally rapid rate. One of the solutions for this is to introduce Distributed Generation (DG). DG is an emerging concept in the electricity sector, which represents good alternatives for electricity supply instead of the traditional centralized power generation concept. DG is a method of generating electricity on a small-scale from renewable and non-renewable energy sources. Systems are located close to where the electricity is being used, and serve as an alternative to or an enhancement of the traditional electric power system.

The advantages of DG are that it increases reliability of the grid, can be configured to match customer demand, diversifies the range of energy sources used, and reduces the necessity to build new transmission and distribution lines, or upgrade existing ones. Growing DGs can improve the quality of atmosphere and reduce green house effect. The different types of DG technologies available are wind, solar, fuel cell, micro-hydro, CHP (combined heat and power), and biomass. Fuel cells are not only very efficient but also have very low

emission levels. Fuel cells directly convert fuel and an oxidant into electricity through an electro chemical process [1]. PV panels are widely available for both commercial and domestic use. They produce no emissions and require minimal maintenance [2]. In some proposed hybrid system studies [8], [12], PI controllers are used to regulate the output powers from DGs to achieve power balance condition due to sudden changes in generation and load. The gain values of PI controllers are chosen by trial and error method.

Though there are several optimization approaches available such as genetic algorithm, particle swarm optimization, artificial neural network no literature survey reported to apply this approaches in the field of hybrid DG for optimization of PI controller gains. In the traditional approach sequential optimization is used where one parameter is optimized at a time using ISE criterion keeping the other parameters fixed and then repeating this operation for every other parameters intern to complete one iteration of optimization. When the number of parameters to be optimized is large, classical technique for optimization is certainly not preferred one. GA can effectively explore many region of search space simultaneously rather than a single region. Hence, GA is less sensitive to local minimum as compared to the conventional approach. GA manipulates the representation of potential solution, rather than the solutions itself. To overcome the possibility of being trapped into local minima only two operations crossover and mutation are performed. Recent research has identified some of the deficiencies in GA performance [5]. The premature convergence of GA degrades its efficiency and reduces the search capability. To overcome this problem a more recent and powerful technique Bacterial Foraging (BF) is available in which the number of parameters that are used for searching the total solution space is much higher compared to those in GA [4] and hence the possibility of overriding local minimum in BF is much higher than in GA. BF technique meanwhile has been successfully applied in some of the areas of electrical engineering [7], [10] where they have shown the superiority of BF over GA. However it has not been applied in the field of hybrid DG systems yet.

In view of the above, the present work dwells in the application of bacterial foraging technique for optimization of controller's gain values in the area of hybrid DG systems. Further, the performance of BF technique is duly compared to the performance of classical technique. Bacterial foraging strategy is quite faster in optimization leading to reduction in computation burden, giving rise to minimal computer resource utilization compare to classical method.

R. Satish is with Anil Neerukonda Institute of Technology & Sciences, Visakhapatnam, 531162, Andhra Pradesh, India (Ph.No.+91-9550-282030, e-mail: satish.raavi03@gmail.com).

Dr. G. Raja Rao is with Anil Neerukonda Institute of Technology & Sciences, Visakhapatnam, 531162, Andhra Pradesh.

II. SYSTEM STUDIES

The proposed system consists of a photo voltaic system, diesel generator, fuel cell, aqua electrolyzer, and battery storage system. The output power of PV is linearly varied with solar radiation if ambient temperature value keep constant [9].

The power supplied to the load is the sum of output powers from photo voltaic system, diesel generator, fuel cell and battery energy storage system. The aqua electrolyzer is used to absorb the fluctuations of solar radiation and produce the hydrogen gas which is used as input to fuel cell generator.

The proposed system simulation model is shown in Fig. 1. The mathematical models with first order transfer functions for photo voltaic system, fuel cell, aqua electrolyzer, diesel engine generator are shown in this section.

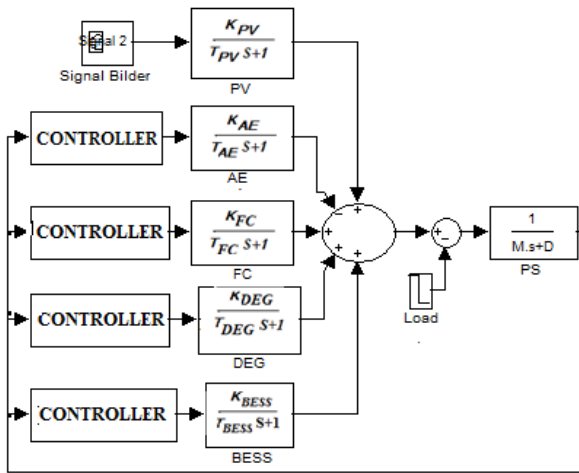

Fig. 1 Configuration of proposed DG System

A. Characteristics of PV Output Power

The sun is an abundant and readily available source of energy. A photo voltaic system captures the sun's energy and converts it into usable electricity.

The output power of studied PV system is determined by [9]

$$P_{PV} = \eta S \Phi \{1 - 0.005(T_a + 25)\} \quad (\text{KW}) \quad (1)$$

where η is the conversion efficiency of PV array, S is the measured area of PV array (m^2), Φ is the solar radiation (kW/m^2), and T_a is the ambient temperature. Generating power of PV system depends on ambient temperature and solar radiation because conversion efficiency of PV array and area of PV array are constant. In this paper assuming ambient temperature is constant and output power of PV array varied by solar radiation only.

The transfer function model of PV represented by a first order lag as [8]

$$G_{PV}(S) = \frac{K_{PV}}{T_{PV}S + 1} \quad (2)$$

where, T_{PV} , G_{PV} are the time constant and gain of photo voltaic system. The values of T_{PV} and K_{PV} are 1.8 s and 1.0 respectively.

B. Aqua Electrolyzer

It is a device used to produce the hydrogen. The decomposition of water into hydrogen and oxygen can be achieved by passing the electric current between the two electrodes separated by aqueous electrolyte [12]. Part of generated energy from the photovoltaic system is sent to the aqua electrolyzer to produce hydrogen for fuel cell [11].

The transfer function model of aqua electrolyzer is given by

$$G_{AE}(S) = \frac{K_{AE}}{T_{AE}S + 1} \quad (3)$$

where K_{AE} and T_{AE} represents the gain and time constant of AE. The value of T_{AE} is very small because AE consists of several power converters [6]. The values of K_{AE} and T_{AE} are 0.002 and 0.5s respectively [11].

C. Fuel Cell

Fuel cells are not only very efficient but also have very low emission levels. Fuel cell power generation systems provide a clean alternative to the conventional fossil fuel based systems. FC is an electrochemical device that continuously converts the chemical energy of a fuel and oxidant into electrical energy and heat as long as the fuel and oxidant are supplied to the electrodes. Fuel cell generators are of higher order models and have non linearity. However in low frequency domain analysis it is represented by a first order lag transfer function model given as

$$G_{FC}(S) = \frac{K_{FC}}{T_{FC}S + 1} \quad (4)$$

where K_{FC} and T_{FC} represents the gain and time constant of fuel cell. The values of K_{FC} and T_{FC} are 0.01 and 4s respectively [11].

D. Diesel Generator

Diesel prime movers are attractive for applications requiring fast responding backups at the time of peak load demands.

The diesel generator is represented as first order transfer function given by [11].

$$G_{DEG}(S) = \frac{K_{DEG}}{T_{DEG}S + 1} \quad (5)$$

where K_{DE} and T_{DE} represents the gain and time constant of diesel generator. The values of K_{DE} and T_{DE} are 1/300 and 2s respectively.

E. Battery Energy Storage System

Energy storage technologies allow generation facilities to be more evenly utilized. Additional electric energy generated during off-peak hours can be converted and stored, then

reconverted for use during peak hours. Small-scale storage options will become more important in the future due to increasing capacity of intermittent renewable energy sources like wind turbines and photo voltaic systems. Batteries are one of the most-effective energy storage technologies available, with energy stored electrochemically [3].

The transfer function model of battery energy storage system represented by first order as

$$G_{BESS} = \frac{K_{BESS}}{T_{BESS}s + 1} \quad (6)$$

where K_{BESS} and T_{BESS} represents the gain and time constant of battery energy storage system. The values of K_{BESS} and T_{BESS} are 1/300 and 0.1s. [11].

F. Power and Frequency Deviation

In a power system, the output frequency is depends on the generation and load. If generation or load changes then automatically power system frequency deviates. To achieve stable operation the error in frequency should be minimum. The deviation in power is the difference between net output power to the total load demand:

$$\Delta P_e = P_s - P_L \quad (7)$$

Since there exists a time delay between system frequency variation and power deviation, the transfer function for system frequency variation to per unit power deviation is given by

$$\Delta f = \frac{1}{Ms + D} \quad (8)$$

where M and D are, equivalent inertia constant and damping constant of power system respectively, and K is the system frequency characteristic constant. The values of M and D are 0.012 and 0.2 respectively [12].

III. BACTERIAL FORAGING TECHNIQUE

A new evolutionary computation technique, called bacterial foraging (B.F) scheme has been proposed by Passino [4] in which the number of parameters that are used for searching the total solution space is much higher compared to those in GA. In this scheme, the foraging behavior of E. coli bacteria present in our intestine is mimicked. The control system of these bacteria that dictates how foraging should proceed can be subdivided into four sections namely Chemotaxis, Swarming, Reproduction and Elimination and Dispersal.

A. Chemotaxis

This process is achieved through swimming and tumbling via Flagella. Depending upon the rotation of Flagella in each bacterium, it decides whether it should move in a predefined direction (swimming) or altogether in different directions (tumbling), in the entire lifetime. To represent a tumble, a unit

length random direction, say $\phi(j)$, is generated; this will be used to define the direction of movement after a tumble.

In particular

$$\theta^i(j+1, k, l) = \theta^i(j, k, l) + C(i)\phi(j) \quad (9)$$

where $\theta^i(j, k, l)$ represents the i^{th} bacterium at j^{th} chemotactic, k^{th} reproductive and l^{th} elimination and dispersal step. $C(i)$ is the size of the step taken in the random direction specified by the tumble (run length unit)

B. Swarming

During the process of reaching towards the best food location it is always desired that the bacterium which has searched the optimum path should try to provide an attraction signal to other bacteria so that they swarm together to reach the desired location. In this process, the bacteria congregate into groups and hence move as concentric patterns of groups with high bacterial density. The mathematical representation for swarming can be represented by

$$\begin{aligned} J_{cc}(\theta, P(j, k, l)) &= \sum_{i=1}^S J_{cc}^i(\theta, \theta^i(j, k, l)) \\ &= \sum_{i=1}^S \left[-d_{attract} \exp \left(-\omega_{attract} \sum_{m=1}^p (\theta_m - \theta_m^i)^2 \right) \right] \\ &+ \sum_{i=1}^S \left[h_{repellent} \exp \left(-\omega_{repellent} \sum_{m=1}^p (\theta_m - \theta_m^i)^2 \right) \right] \end{aligned} \quad (10)$$

where $J_{cc}(\theta, P(j, k, l))$ is the cost function value to be added to the actual cost function to be minimized to present a time varying cost function. 'S' is the total number of bacteria and 'p' the number of parameters to be optimized which are present in each bacterium. $d_{attract}, \omega_{attract}, h_{repellent}, \omega_{repellent}$ are different coefficients that are to be chosen properly.

C. Reproduction

The least healthy bacteria die and the other healthiest bacteria each split into two bacteria, which are placed in the same location. This makes the population of bacteria constant.

D. Elimination and Dispersal

It is possible that in the local environment the live of a population of bacteria changes either gradually (e.g., via consumption of nutrients) or suddenly due to some other influence. Events can occur such that all the bacteria in a region are killed or a group is dispersed into a new part of the environment. They have the effect of possibly destroying the chemotactic progress, but they also have the effect of assisting in chemotaxis, since dispersal may place bacteria near good food sources. From a broad perspective, elimination and dispersal are parts of the population-level long-distance motile behavior.

IV. BACTERIAL FORAGING ALGORITHM

In case of bacterial foraging technique we assign each variable with a set of bacteria (S). Each variables in a bacteria is assigned a random value (Δ) as mentioned below in the iterative algorithm within the universe of discourse defined through upper and lower limit within which the optimum value of variable likely to fall. Each Bacterium is allowed to take all possible values within the range and evaluate the performance index/cost. The actual objective function to be minimized is the integral square error (ISE) which is defined by (8);

$$J = \int_0^T (\Delta f)^2 dt \tag{11}$$

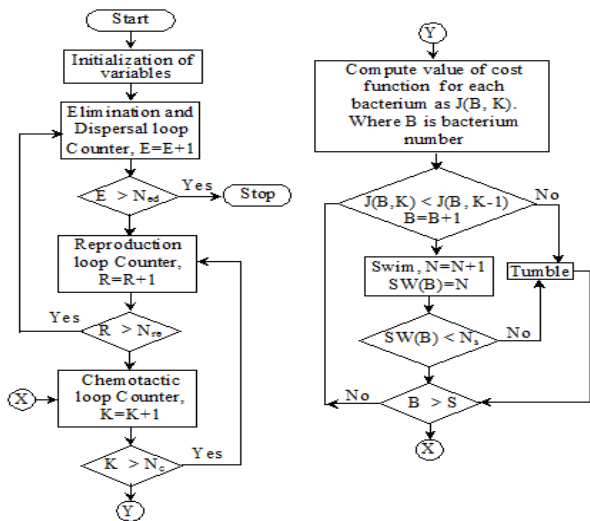

Fig. 2 Flow chart for bacterial foraging algorithm

In this paper, the BF algorithm suggested in [4] is used to expedite the convergence. In this simulation work we have considered $S=6$, $N_c=10$, $N_s=3$, $N_{re}= 20$, $N_{ed}= 2$, $P_{ed}=0.25$, $d_{attract} = 0.01$, $\omega_{attract} = 0.04$, $h_{repellent} = 0.01$ and $\omega_{repellent} = 10$. The value of p is taken as 8.

The flow chart of the bacterial foraging algorithm is shown in Fig. 2

V. RESULTS AND ANALYSIS

This section presents the time domain performance of the proposed hybrid DG system. In all the cases simulation interval is taken as 300s.if generation and load changes the power system frequency deviates this deviation is controlled using the I, PI and PID controller. The controllers' gains are selected by bacterial foraging optimization technique. The changes in generation and load are automatically adjusted by DG sources.

A. Case I: By Using I Controller

1. Load Increases from 1 to 1.3 pu

In this case I controller is installed before the DEG, AE, FC and BESS. Solar radiation is kept 0.5 pu up to 300s and load demand is 1 pu. Up to 150s and after 150s load is suddenly increases from 1 to 1.3 pu. The power system frequency fluctuates due to changes in load, if load increases then frequency decreases to corresponding value. This deviation in frequency is controlled by the I controllers and the outputs of DGs are automatically adjust to corresponding values such that the error in supply demand and the deviation in frequency are minimum. The gain values of I controllers which are installed before AE, FC, DEG and BESS obtained through BF technique and classical method are $K_{I1}=5.9753$, $K_{I2}= 8.123$, $K_{I3}=3.1664$, $K_{I4}= 3.5406$, $K_{I1*}=5.324$, $K_{I2*}= 9.241$, $K_{I3*}= 2.867$, $K_{I4*}= 3.258$.The deviation in frequency and error in supply demand are shown in Figs. 3 and 4 respectively. In Fig. 3 due to sudden increase in load at 150s, frequency decreases to corresponding value and then remains constant.

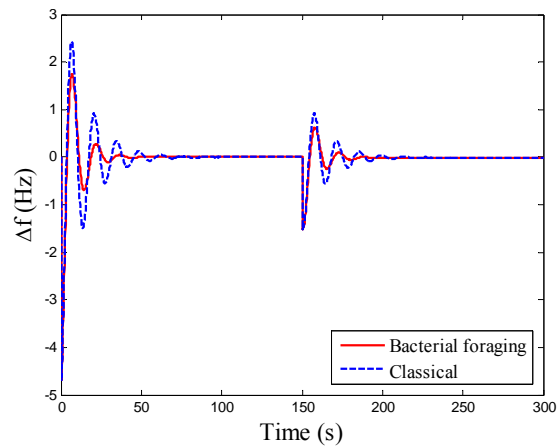

Fig. 3 Simulation results for deviation in frequency in the system with I controller, when load suddenly increase

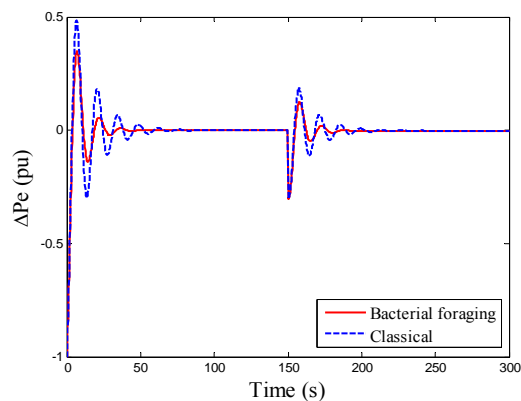

Fig. 4 Simulation results for error in supply demand in the system with I controller, when load suddenly increase

2. Load Decreases from 1 to 0.7 pu

In this case I controller is installed before the DEG, AE, FC and BESS. Solar radiation is kept 0.5 pu up to 300s and load demand is 1 pu. Up to 150s and after 150s it is suddenly decreases from 1 to 0.7 pu. The power system frequency fluctuates due to changes in load, if load decreases then frequency increases to corresponding value. This deviation in frequency is controlled by the I controllers and the outputs of DGs are automatically adjust to corresponding values such that the error in supply demand and the deviation in frequency are minimum. The deviation in frequency and error in supply demand are shown in Figs. 5 and 6 respectively.

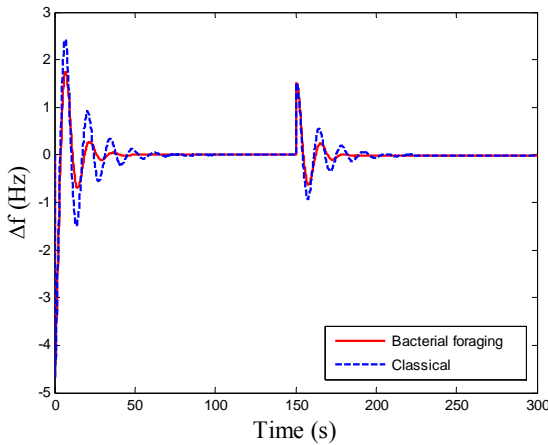

Fig. 5 Simulation results for deviation in frequency in the system with I controller, when load suddenly decreases

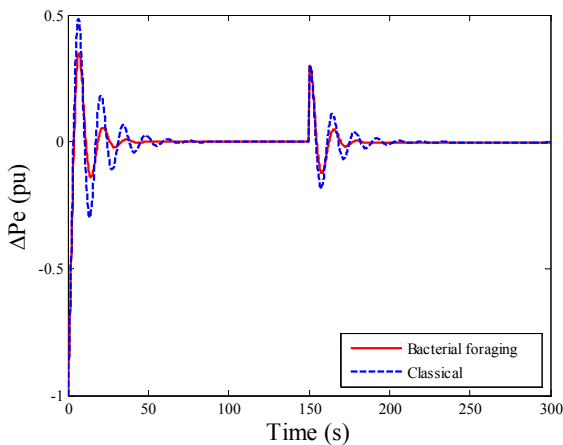

Fig. 6 Simulation results for error in supply demand in the system with I controller, when load suddenly decreases

B. Case II: By Using PI Controller

1. Load Increases from 1 to 1.3 Pu

In this case PI controllers are installed before the DEG, AE, FC and BESS. Solar radiation is kept 0.5 pu up to 300s and load demand is 1 pu. Up to 150s and after 150s it is suddenly increases from 1 to 1.3 pu. The power system frequency fluctuates due to changes in load, if load increases

then frequency decreases to corresponding value. This deviation in frequency is controlled by the PI controllers and the outputs of DGs are automatically adjusted to corresponding values such that the error in supply demand and the deviation in frequency are minimum. The gain values of PI controllers which are installed before AE, FC, DEG and BESS obtained through BF technique and classical method are $K_{P1} = 3.3476$, $K_{P1*} = 4.5016$, $K_{I2} = 8.7526$, $K_{P2} = 9.606$, $K_{I3} = 8.7288$, $K_{P3} = 9.926$, $K_{I4} = 5.2217$, $K_{P4} = 2.104$, $K_{I1*} = 4.52$, $K_{P1*} = 3.675$, $K_{I2*} = 9.427$, $K_{P2*} = 6.588$, $K_{I3*} = 5.598$, $K_{P3*} = 5.845$, $K_{I4*} = 4.487$, $K_{P4*} = 3.02$. The deviation in frequency and error in supply demand are shown in Figs. 7 and 8 respectively.

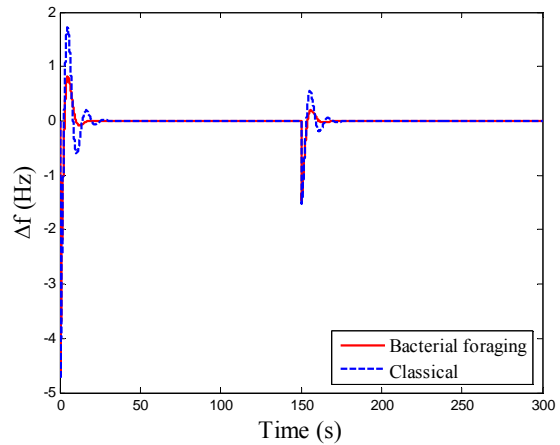

Fig. 7 Simulation results for deviation in frequency in the system with PI controller, when load suddenly increases

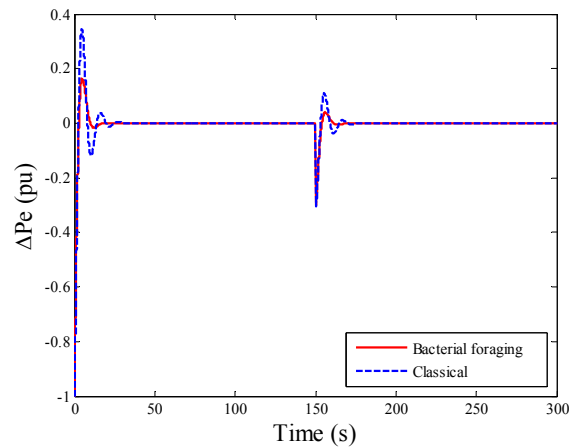

Fig. 8 Simulation results for error in supply demand in the system with PI controller, when load suddenly increase.

2. Load Decreases from 1 to 0.7 pu

The PI controllers are installed before the DEG, AE, FC and BESS. Solar radiation is kept 0.5 pu up to 300s and load demand is 1 pu. Up to 150s and after 150s it is suddenly decreases from 1 to 0.7 pu. The deviation in frequency is controlled by the PI controllers and the outputs of DGs are automatically adjusted to corresponding values such that the error in supply demand and the deviation in frequency are

minimum. The deviation in frequency and error in supply demand are shown in Figs. 9 and 10 respectively.

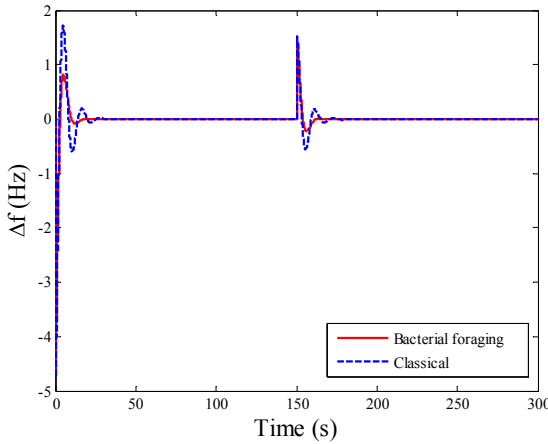

Fig. 9 Simulation results for deviation in frequency in the system with PI controller, when load suddenly decreases

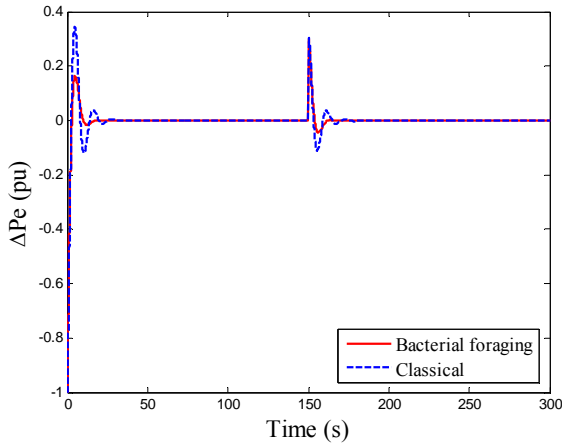

Fig. 10 Simulation results for error in supply demand in the system with PI controller, when load suddenly decreases

C. Case III: By Using PID Controller

1. Load Increases From 1 to 1.3 pu

In this case PID controllers are installed before the DEG, AE, FC and BESS. Solar radiation is kept 0.5 pu up to 300s and load demand is 1 pu. Up to 150s and after 150s load is suddenly increases from 1 to 1.3 pu. The power system frequency fluctuates due to changes in load, if load increases then frequency decreases to corresponding value. This deviation in frequency is controlled by the PID controllers and the outputs of DGs are automatically adjusted to corresponding values such that the error in supply demand and the deviation in frequency are minimum. The gain values of PID controllers which are installed before AE, FC, DEG and BESS obtained through BF technique and classical method are $K_{I1} = 0.66751$, $K_{P1} = 2.0566$, $K_{D1} = 8.5477$, $K_{I2} = 5.8544$, $K_{P2} = 7.2815$, $K_{D2} = 6.9173$, $K_{I3} = 3.5823$, $K_{P3} = 9.6688$, $K_{D3} = 4.4385$, $K_{I4} = 6.4006$, $K_{P4} = 3.0692$, $K_{D4} = 2.4872$, $K_{I1}^* =$

0.7178 , $K_{P1}^* = 1.7613$, $K_{D1}^* = 8.935$, $K_{I2}^* = 5.668$, $K_{P2}^* = 7.44$, $K_{D2}^* = 6.852$, $K_{I3}^* = 4.278$, $K_{P3}^* = 8.138$, $K_{D3}^* = 4.965$, $K_{I4}^* = 6.658$, $K_{P4}^* = 4.668$, $K_{D4}^* = 2.985$. The deviation in frequency and error in supply demand are shown in Figs. 11 and 12 respectively.

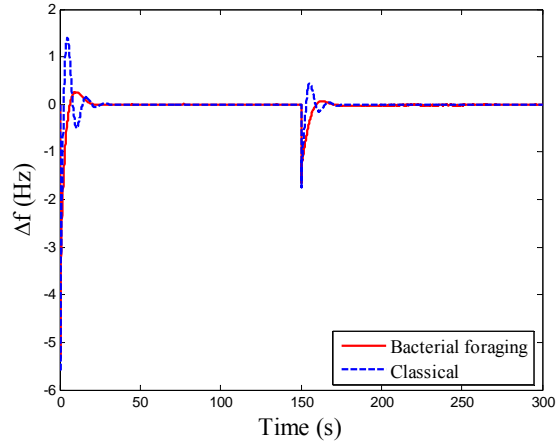

Fig. 11 Simulation results for deviation in frequency in the system with PID controller, when load suddenly increases

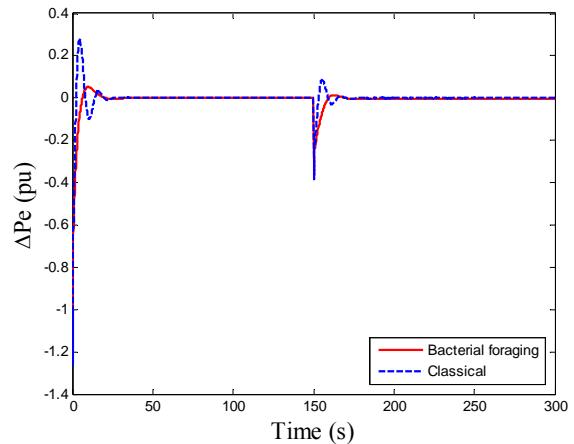

Fig. 12 Simulation results for error in supply demand in the system with PID controller, when load suddenly increase

2. Load Decreases From 1 to 0.7 pu

The PID controllers are installed before the DEG, AE, FC and BESS. Solar radiation is kept 0.5 pu up to 300s and load demand is 1 pu. Up to 150s it is suddenly decreases from 1 to 0.7 pu. The deviation in frequency is controlled by the PID controllers and the outputs of DGs are automatically adjusted to corresponding values such that the error in supply demand and the deviation in frequency are minimum. The deviation in frequency and error in supply demand are shown in Figs. 13 and 14 respectively.

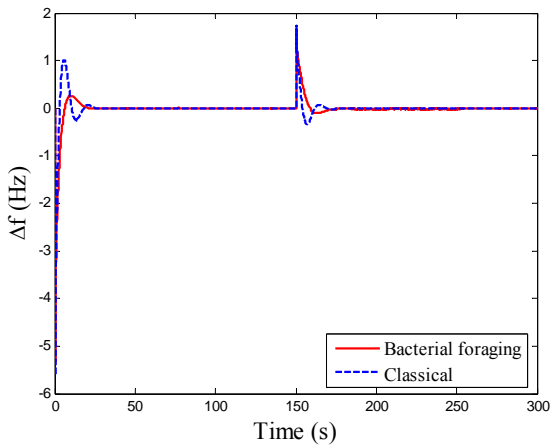

Fig. 13 Simulation results for deviation in frequency in the system with PID controller, when load suddenly decreases

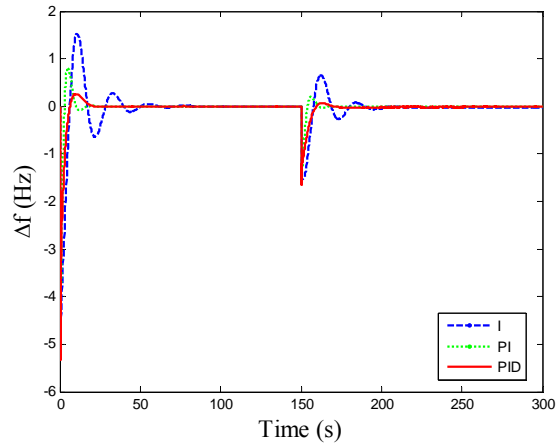

Fig. 15 Simulation results for deviation in frequency in the system with I, PI, PID controller, when load suddenly increases at 150s

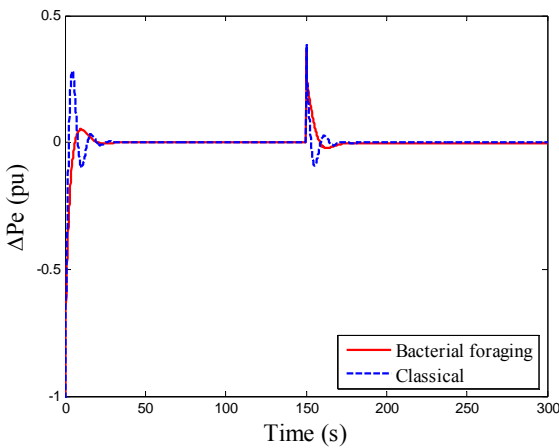

Fig. 14 Simulation results for error in supply demand in the system with PID controller, when load suddenly decreases

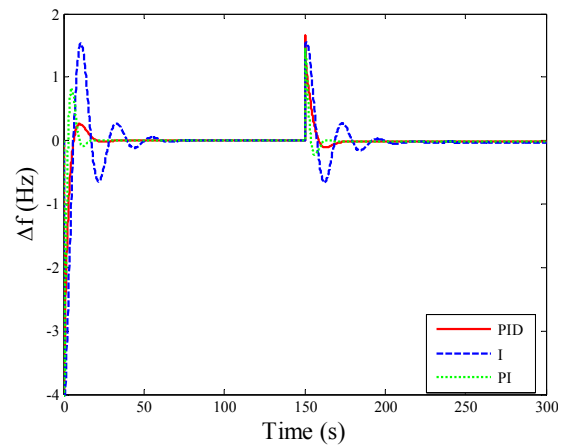

Fig. 16 Simulation results for deviation in frequency in the system with I, PI, PID controller, when load suddenly decreases at 150s

D. Case IV: Comparison of System Responses with I, PI and PID Controllers

In this case the system frequency responses for different loading conditions with I, PI and PID controllers is studied. Fig. 15 represents the deviation in frequency when load is suddenly increases from 1 to 1.3 pu at 150s and Fig. 16 represents the deviation in system frequency when load is suddenly decreases from 1 to 0.7 pu at 150s. In both the conditions the frequency changes at 150s and after made constant by using controllers which are installed before the DG sources. After observing the simulation results, PID controller is best to control the frequency of proposed DG hybrid system.

E. Case V: Sensitivity Analysis

In this section load sensitivity analysis is studied. Fig. 17 shows that frequency deviation when 30% increase in load at 150s with corresponding gain values when there is no perturbation with 30% increase in load at 150s with corresponding optimum gain values. Fig. 18 shows that frequency deviation when 30% decrease in load at 150s with corresponding gain values when there is no perturbation with 30% decrease in load at 150s with corresponding optimum gain values. The decrease in frequency at 70s is due to sudden decrease of solar radiation from 0.5 to 0.2 pu in both the conditions. The optimum gain values when 30% increase in load are $K_{I1} = 0.9612$, $K_{P1} = 2.5321$, $K_{D1} = 9.543$, $K_{I2} = 5.012$, $K_{P2} = 6.1012$, $K_{D2} = 7.191$, $K_{I3} = 4.621$, $K_{P3} = 10.612$, $K_{D3} = 5.123$, $K_{I4} = 6.121$, $K_{P4} = 4.961$, $K_{D4} = 3.124$.

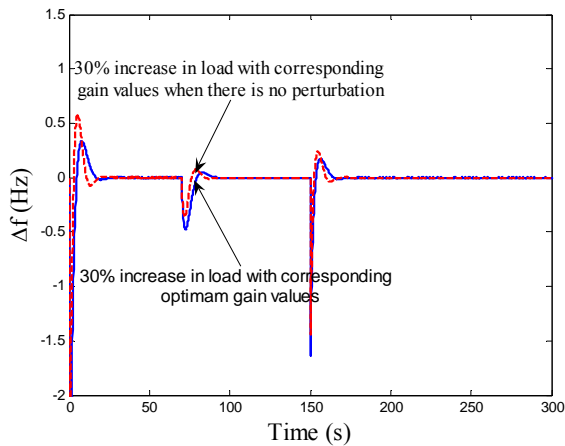

Fig. 17 Sensitivity analysis for frequency deviation when load increases at 150 s

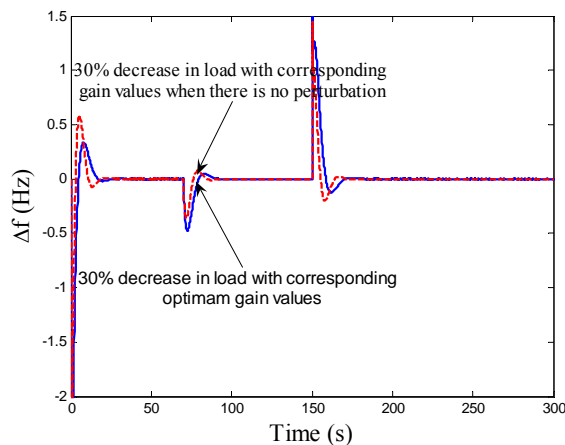

Fig. 18 Sensitivity analysis for frequency deviation when load decreases at 150 s

The optimum gain values when 30% decrease in load are $K_{I1} = 1.123$, $K_{P1} = 2.862$, $K_{D1} = 9.512$, $K_{I2} = 7.123$, $K_{P2} = 6.586$, $K_{D2} = 7.191$, $K_{I3} = 4.861$, $K_{P3} = 10.891$, $K_{D3} = 5.649$, $K_{I4} = 7.015$, $K_{P4} = 4.320$, $K_{D4} = 4.057$.

VI. CONCLUSION

The proposed hybrid DG system consisting of photovoltaic system, aqua electrolyzer, fuel cell, diesel generator and battery energy storage system is studied. When the generation and load changes, the frequency of system deviates. This deviation in frequency is controlled by using I, PI and PID controllers which are installed before the DEG, FC, AE and BESS. The gains of each controller are designed by using classical method and bacterial foraging optimization technique. Results reveal that bacterial foraging optimization technique is much better and PID controller gives best results among other controllers. Sensitivity analysis reveals that the optimum gain values at the nominal loading condition are quite robust and need not be reset for wide changes in system loading condition.

REFERENCES

- [1] David J. Hall, R. Gerald Colclaser, "Transient Modeling and Simulation of a Tubular Solid Oxide Fuel Cell". *IEEE Trans on Energy Conversion*, Vol. 14, No.3, September 1999.
- [2] Toshihisa Shimizu, Masaki Hirakata, Tomoya Kamezawa, Hisao Watanabe, "Generation Control Circuit for Photovoltaic Modules". *IEEE Trans. On power Electronics*, Vol. 16, No.3, MAY2001.
- [3] Paulo F. Ribeiro, Brain K. Johnson, Mariesa L. Crow, Aysen Arsoy, Yilu Liu, "Energy Storage Systems for Advanced Power Applications," *Proceedings of IEEE*, Vol, No. 12, December 2001
- [4] K. M. Passino, "Biomimicry of Bacterial Foraging for Distributed Optimisation and Control," *IEEE Control System Magazine*, June 2002.
- [5] M. A. Abido, "Optimal Design of Power-System Stabilizers Using Particle Swarm Optimization," *IEEE Trans. Energy Convers.*, vol. 17, no. 3, pp. 406–413, Sep. 2002
- [6] Kaushik Rajashekara, "Hybrid Fuel Cell Strategies for Clean Power Generation", *IEEE Trans on Industry applications*, vol, 41, No.3, May/June 2005.
- [7] S. Mishra, "A Hybrid Least Square-Fuzzy Bacterial Foraging Strategy for Harmonic Estimation," *Evolutionary Computation*, IEEE Transactions, Feb 2005, Volume 9, Issue 1, Page(s):61 – 73
- [8] T.Senjyu, T. Nakaji, K. Uezato, and T. Funabashi, "A Hybrid Power System Uses Alternative Energy Facilities in Isolated Islands," *IEEE Trans. Energy convers*, Vol. 20,
- [9] Hayashi, D, Senjyu, T, Sakamoto, R, Uasaki, N, Funabashi, T, Sekine, H. "Generating Power Levelling of Renewable Energy for Small Power System in Isolated Island," 6-10 Nov.2005 Page(s) 6 pp.
- [10] S. Mishra, C. N Bhende, "Bacterial Foraging Technique-Based Optimized Active Power Filter for Load Compensation," *Power Delivery*, IEEE Transactions on Volume 22, Issue 1, Jan. 2007 Page(s):457 – 465.
- [11] Dong-Jing Lee and Li Wang, "Small-Signal Stability Analysis of an Autonomous Hybrid Renewable Energy Power Generation/ Energy Storage System Part I: Time- Domain Simulations. *IEEE Trans on Energy Conversion*, Vol, 23, NO. 1, March 2008.
- [12] Kumar, B.S, Mishra, S, "Agc for Distributed Generation", Pages 89-94 24-27 Nov-2008.