

Design of a Hybrid Fuel Cell with Battery Energy Storage for Stand-Alone Distributed Generation Applications

N. A. Zambri, A. Mohamed, H. Shareef, and M. Z. C. Wanik

Abstract—This paper presents the modeling and simulation of a hybrid proton exchange membrane fuel cell (PEMFC) with an energy storage system for use in a stand-alone distributed generation (DG) system. The simulation model consists of fuel cell DG, lead-acid battery, maximum power point tracking and power conditioning unit which is modeled in the MATLAB/Simulink platform. Poor load-following characteristics and slow response to rapid load changes are some of the weaknesses of PEMFC because of the gas processing reaction and the fuel cell dynamics. To address the load-tracking issues in PEMFC, a hybrid PEMFC and battery storage system is considered and modelled. The model utilizes PEMFC as the main energy source whereas the battery functions as energy storage to compensate for the limitations of PEMFC. Simulation results are given to show the overall system performance under light and heavy loading conditions.

Keywords—Hybrid, Lead-Acid Battery, Maximum Power Point Tracking, Proton Exchange Membrane Fuel Cell.

I. INTRODUCTION

IN recent years, renewable and clean energy resources are becoming increasingly important due to the problems of energy shortage and the increasing environmental issues such as air pollution and global warming. One of the alternative sources of electric power is fuel cell technology which has been the subject of increasing interest. Fuel cell is a promising form of renewable energy which promises many advantages such as high efficiency, high power density, absence of combustion, silent technology and the ability to be stored anywhere. PEMFC is a type of fuel cell that can work in low temperature condition and has a relatively short start-up time [1].

However, PEMFC have some problems such as slow transient response to load changes and fluctuating output voltage when the input current changes [2]. Due to these problems, energy storage system is needed to work together with PEMFC in order to achieve good performance and quick dynamic response during increasing electrical load. This paper presents a simulation model of a hybrid PEMFC and battery storage system. A DC/DC boost converter is connected after

the fuel cell to ensure proper voltage level at the DC bus and a DC/DC bidirectional converter is connected between the DC bus and the battery to control the power flow and to enable the charging and discharging process between DC bus and the battery. MPPT method is included in the model to ensure optimum use of PEMFC.

Many works have been done in the simulation and modelling of a hybrid FC system. This study mainly focuses on modelling and control of a hybrid fuel cell and battery system with an MPPT controller. The following sections in this paper will describe the overall system together with explanations of each individual element as well as the proposed control strategy including the description on modelling process and the simulation works.

II. MODEL DESCRIPTION

A hybrid PEMFC/lead-acid battery system is designed as shown in Fig. 1 in which the PEMFC and battery model is connected to a common DC bus through a boost converter and a buck-boost converter, respectively. With this configuration, the battery will function as a back-up power to balance the system's power flow for load voltage regulation. A step-load change replicates the stand-alone DG system and provides the basis for assessing the features of the battery system.

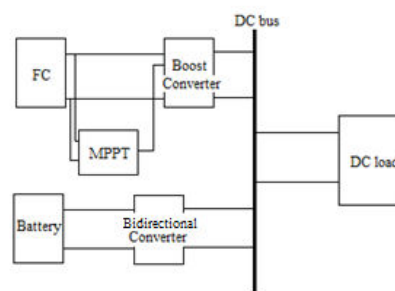

Fig. 1 Configuration of the stand-alone hybrid FC/Battery generation system

The proposed PEMFC/battery system configuration is to mitigate the slow response of the fuel cell (FC) output voltage during rapid load changes, to ensure the FC operates at its optimum capacity and to supply electrical power to the load when the FC reaches its maximum power rating. The system's operating principle is based on the battery's capability to solve the problems of the FC. A MPPT controller is used to ensure

N. A. Zambri is with the Faculty of Electrical and Electronics, Universiti Tun Hussein Onn Malaysia, 86400 Parit Raja, Batu Pahat Johor, Malaysia. (phone: +6012-4646319, e-mail: aira@uthm.edu.my)

A. Mohamed, H. Shareef, and M. Z. C. Wanik are with the Department of Electrical, Electronic & Systems Engineering, Universiti Kebangsaan Malaysia (UKM), 43600 Bangi, Selangor, Malaysia (e-mail: azah@eng.ukm.my, shareef@eng.ukm.my, mzamri@eng.ukm.my)

that the FC operates at its MPP. In order to operate at the MPP, the FC output current should be constant, so that load will only receive a fixed current and power. Thus, during any variation of loads, the battery will charge and discharge to keep the output voltage of the system constant.

A. PEMFC Model

Dynamic model of FC has been developed by several researchers which can be divided into two groups, namely, mathematical and semi-empirical models. Mathematical model is built based on chemical reactions for evaluating the process of FC while semi-empirical model is based on combination of experimental data with parametric equations adjusted by comparison with FC physical variables. The first part of this paper develops a dynamic model of PEMFC based on the equations of electrochemical reactions. The model takes into consideration all the voltage drops and also the double-layer charging effect that occurs in the PEMFC stack including proportional-integral-derivative (PID) controller used to control the gas flow in reformer. The double-layer charge effect is the collection of charges at the surface of the electrodes that generate electrical voltage. This layer of charge near the electrode interfaces can store electrical charge and function as a large electrical capacitor. This layer is considered important when designing an electrical model of PEMFC. The model considers the temperature criteria because in real cases, temperature characteristics are not constant. This temperature is influenced by the net heat generation rate and the chemical reactions that occur inside the stack.

The PEMFC model is designed based on the polarization curve of PEMFC with the Nernst equation and the double-layer charge effect that occurs in the FC stack [3]. The actual voltage at the FC terminals is lower than the internal potential, E that is obtained from the Nernst equation. This occurrence is due to the existence of the double-layer charge effect as well as the presence of the activation, concentration, and ohmic voltage drops that occur inside the FC stack. The FC output voltage is given by,

$$V_{out} = N_0 (E - V_{act} - V_C - V_{ohm}) \quad (1)$$

The corresponding Nernst equation used in this model is given by:

$$E = (1.229 + 0.0085(T - 298.15) + 4.31 \times 10^{-5} \left[\frac{P_{H_2} \sqrt{P_{O_2}}}{P_{H_2O}} \right]) \quad (2)$$

where F is the Faraday constant (96487C), R is the universal constant for gas (8.314J/Kmol), T is the operational temperature, T_{ref} is the reference temperature, and P_{H_2} , P_{O_2} and P_{H_2O} are the partial pressures of hydrogen, oxygen and water (atm) respectively and the partial pressure equations can be seen in [4]. There are several losses in the PEMFC model which are activation loss (V_{act}), ohm loss (V_{ohm}) and also

concentration loss (V_{conc}). In (1), concentration losses are not considered because concentration resistance, R_{conc} is included in the V_C equation described below and V_C represents the double-layer charge effect.

$$V_C = I - C \frac{dV_C}{dt} (R_{act} + R_{conc}) \quad (3)$$

In which the concentration equivalent resistance can be written as:

$$R_{conc} = - \frac{RT}{zFI} \ln \left(1 - \frac{I}{I_{limit}} \right) \quad (4)$$

where z is the number of participating electrons. In this reaction, 2 electrons are developed from the hydrogen reaction at the anode. The equivalent resistance of activation is defined by (5) and it can be seen that the resistance is both temperature and current dependent.

$$R_{act} = \frac{T \cdot b \ln I}{I} \quad (5)$$

where b is the empirical constant with a value of 0.016. I is the operating current or the feedback current discussed earlier and the I_{limit} is the fuel cell current limit (A). Activation loss is caused by the slowness of the reactions taking place on the surfaces of the electrodes and can be expressed by

$$V_{act} = \eta_o + (T - 298)a \quad (6)$$

where η_o and a are empirical constants with $\eta_o = 0.4197V$ and $a = -0.1373(V/K)$. Ohmic loss is the voltage drop due to the resistance to the flow of electrons through electrodes and also includes the resistance to the proton flow through electrolytes. Losses of the FC are constant in this region and is given as

$$V_{ohm} = IR_{ohm} \quad (7)$$

$$R_{ohm} = 0.01605 - 3.5 \times 10^{-5} T + 8 \times 10^{-5} I \quad (8)$$

Chemical reaction occurring inside the FC produces a net heat generation rate which causes its temperature to rise or fall. Temperature characteristic is not constant because any variations in temperature will affect the PEMFC performances. The following differential equation shows the thermal action in the FC.

$$C_t \frac{dT}{dt} = i(E - V_{FC}) - H(T - T_f) \quad (9)$$

where C_t is the total thermal capacitance for all the mass of the FC (10J/K), H is the total heat transfer coefficient for all the surface of the FC (10W/K) and T_f is the reference temperature

of the environment (30+273.15K). The differential equations in (3) and (9) are then solved by using a Simulink integrator.

PEMFC stack needs pure hydrogen and oxygen as its input. Fuel processor, or reformer, will convert the fuel such as methane into hydrogen and by-product gases. The produced hydrogen will be fed into the FCstack for further reactions. In the reformer unit, a controller is used in order to control the fuel and hydrogen flow rates in the PEMFC stack. A PID controller system is used for this purpose. Feedback from the stack current is needed to regulate the flow of hydrogen depending to the load requirement. Mathematical equations in [4] are used to build the reformer unit in the Matlab/Simulink environment. The PID controller is used to control the methane flow rate in the reformer with K_p , K_i and K_d being set to 9.5, 0.8 and 6 respectively. The oxygen flow rate is determined by the hydrogen-oxygen flow ratio, r_{h-o} in the reformer.

B. MPPT Model

In order to improve the efficiency of the PEMFC generation system, PEMFC stack should be controlled to generate maximum power with optimization of the fuel consumption. In most situations, it is actually undesirable to operate at a maximum power because normally the fuel efficiency is at best 50%. By applying MPPT, the situation can be solved because MPPT aims at reaching the MPP at different fuel flow rates.

There are various methods to find the maximum point of a function, such as the Perturb and Observe (P&O) algorithm, Incremental Conductance (Inc) algorithm, short-circuit current method and open-circuit voltage method. Due to its simplicity, the P&O algorithm is the most commonly used MPPT method [5]-[7]. In the P&O MPP algorithm, the principle is to provoke perturbation by altering the PWM duty cycle command and observe the PEMFC's output to operate near the maximum point. If the power increases due to perturbation then the perturbation will remain in the same direction or otherwise it is reversed. The P&O MPP algorithm is described in terms of a flowchart as shown in Fig. 2.

C. DC/DC Boost Converter and Its Control

Since the output voltage of PEMFC is low, a DC/DC boost converter is used in order to enable a low-voltage PEMFC to be used. The parameters of the proposed scheme are represented by: a PEMFC stack as DC input voltage source V_{in} , controllable switch, filter inductor L , filter capacitor C , load resistor R , and a PWM block that controls the duty cycle, d . Fig. 3 is the configuration of the boost converter and its control scheme. In Fig. 3, the MPPT controller uses PEMFC voltage, current and subsequently its power, to find the MPP and afterward generates control instruction for the power converter. The boost converter will force the PEMFC to work at current which will define by the MPPT unit.

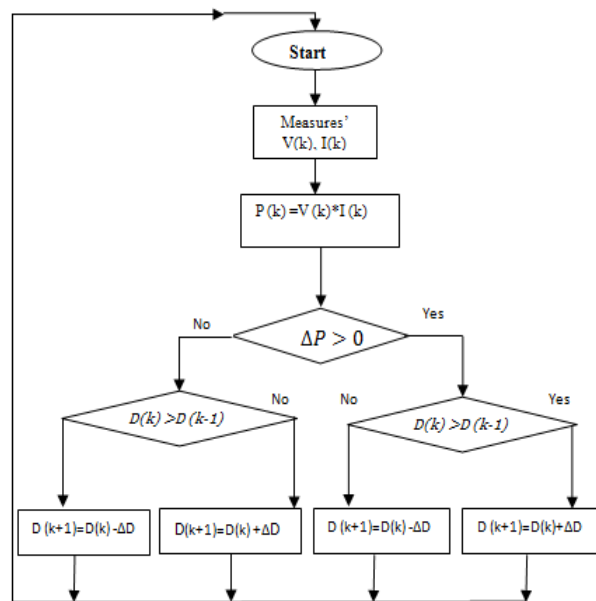

Fig. 2 Flowchart of the P&O algorithm

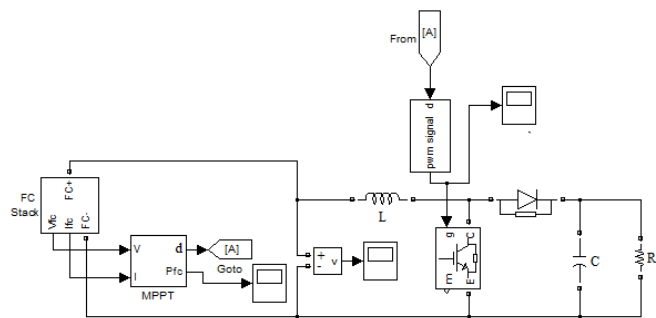

Fig. 3 Boost converter circuit and its control

D. Energy Storage Model

Energy storage system (ESS) covers a wide range of power system applications using various technologies, such as ultra-capacitors, batteries, pumped-storage hydroelectricity, compressed air energy storage, and flywheels. ESS applications in a system can improve the efficiency, enhance the stability and reliability of an electrical utility, correct voltage disturbances, as well as increase the adoption of a renewable energy technology in DG. Batteries are the most popular and most technologically mature options for DG applications, which promise a high energy density and high performance.

To date, various types of batteries have been developed and introduced for large power applications. Fig. 4 shows an equivalent circuit of a battery used in most simulations [8].

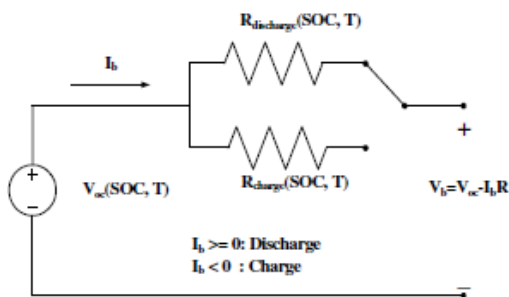

Fig. 4 Battery model

Equations (10) and (11) represent the lead-acid battery model.

Discharge Model ($I_b > 0$):

$$f_1 = E_0 - K \frac{Q}{Q - it} i^* - K \frac{Q}{Q - it} it + \text{Laplace}^{-1} \left(\frac{\text{Exp}(s)}{\text{Sel}(s)}, 0 \right) \tag{10}$$

Charge Model ($I_b < 0$):

$$f_2 = E_0 - K \frac{Q}{it} \frac{1}{0.1Q} i^* - K \frac{Q}{Q - it} it + \text{Laplace}^{-1} \left(\frac{\text{Exp}(s)}{\text{Sel}(s)}, \frac{1}{s} \right) \tag{11}$$

where I_b is the battery current, E_0 is the constant voltage, $\text{Exp}(s)$ is the exponential zone dynamics and Q is the maximum battery capacity in Ah. $\text{Sel}(s)$ represents the battery mode where $\text{Sel}(s)$ is equal to 0 during the discharging process and $\text{Sel}(s)$ will be equal to 1 during the charging mode. In (10) and (11), K symbolizes the polarization constant in Ah^{-1} or also known as polarization resistance in Ohms, while it is the extracted capacity.

Lead-acid battery in the system should be able to operate in two ways in which the battery must be able to charge to store excess energy and to discharge depending on load requirement. Due to that reason, a bidirectional DC/DC converter is needed to ensure continuity of power flow between the DC bus and energy storage. The converter in series with the battery can provide an active control for the battery system. Fig. 5 shows the connection between battery and battery converter with its control mechanism.

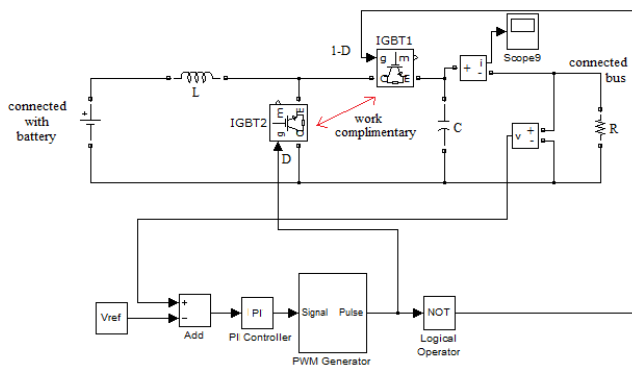

Fig. 5 Bidirectional converter and its control

The primary objective of the battery converter is to maintain the common DC link voltage constant so that the voltage of the DC bus will remain stable either during battery charging or discharging. Fig. 5 shows that there are two IGBTs in the converter configuration in which the two IGBTs operate in complimentary and can be driven by only one PWM signal. The control strategy in this system applied the proportional-integrator (PI) controller with K_p and K_i being set to 8 and 0.5, respectively. The bus voltage is compared with a reference voltage (V_{ref}) to obtain an error signal. The error is then compensated by the PI controller and during charging, IGBT2 is activated and the circuit operates as a boost converter, otherwise, during discharging, IGBT1 is activated and the converter works as a buck converter.

III. MATLAB/SIMULINK MODEL

A complete system model composed of a hybrid stand-alone PEMFC model connected to a lead-acid battery model for DG applications has been developed and simulated using the MATLAB/Simulink program which provides graphical interface as block diagrams. This software offers the advantage which allows a user to view the system at different levels, such that the models are easily connected together. The parameters can be changed during simulation, and the results from different simulations are eventually analyzed.

By applying the PEMFC, MPPT, boost converter, lead-acid battery and the battery converter models described earlier, the complete hybrid system is implemented in the MATLAB/Simulink environment. In this system, MPPT controller is used to ensure FC operates at maximum output power. MPPT is unique and will force the output of PEMFC stack to remain constant at its maximum power. Thus, the battery will absorb or deliver current depending on the variation of the load resistance.

Fig.6 is a complete model of PEMFC and reformer or fuel processor unit is shown in Fig.7. The MPPT unit is shown in Fig.8.

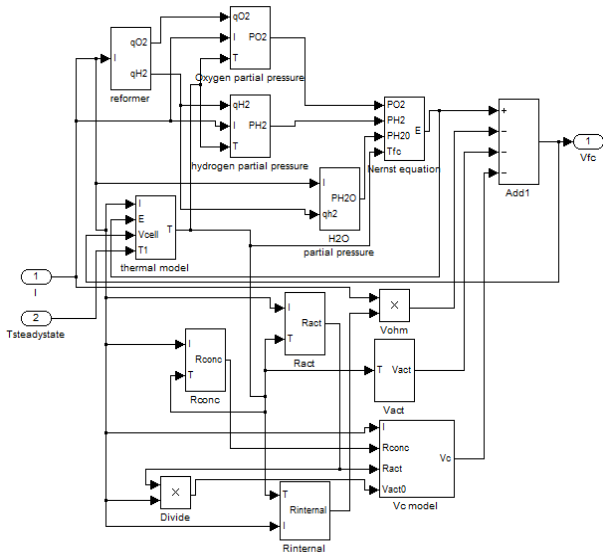

Fig. 6 PEMFC simulation model in MATLAB/SIMULINK

TABLE I
PEMFC MODEL PARAMETERS

Symbols	Values
F	96487 C
R	8.314 J/K
T_{ref}	30+273.15 K
Z	2
B	0.016
η_o	0.4197 V
a	-0.1373 V/K
K_p	9.5
K_i	0.8
K_d	6
C	4.8 F
Ct	10J/K
H	10W/K

TABLE II
PEMFC AND BATTERY CHARACTERISTICS

PEMFC	
Maximum power (W)	5000
Number of cells	180
LEAD-ACID BATTERY	
Nominal voltage(V)	480
Initial SOC(%)	80
Rated capacity (Ah)	6.5

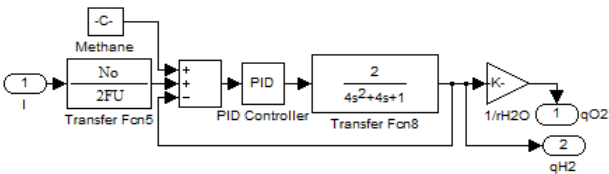

Fig. 7 Reformer model

IV. RESULTS AND DISCUSSION

Simulations were performed on a complete hybrid PEMFC and a lead-acid battery system with its power conditioning circuit for stand-alone analysis of a DG system using MATLAB/Simulink. The simulation is done to analyse the battery response in this hybrid system. In order to investigate the performance of the system, a step change of loads are applied as shown in Fig. 9.

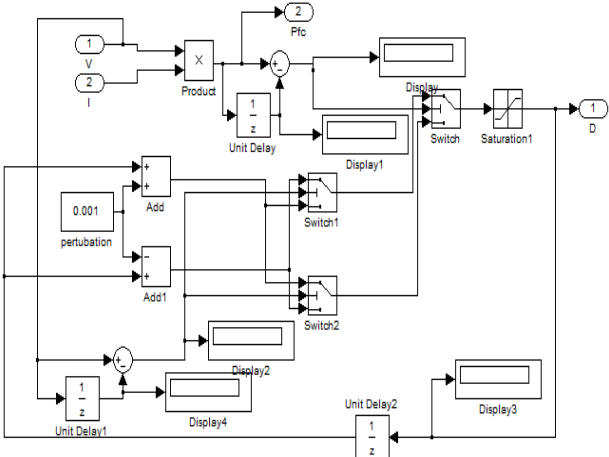

Fig. 8 P and O MPP Simulink model

Table I show the parameter used in PEMFC model while the PEMFC and battery characteristics criteria for the whole system are summarized in Table II.

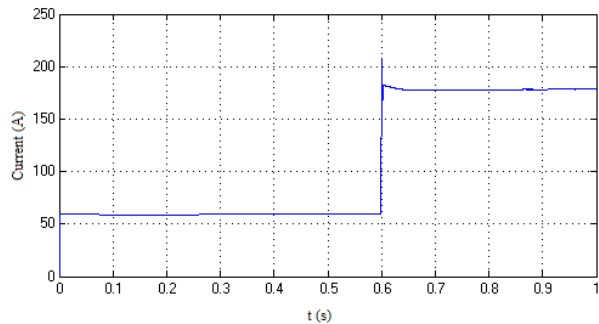

Fig. 9 Step changes of load current

Fig. 10 is the FC output power and it can be seen that loads variations have no impact on the MPPT controller performance and MPP is traced smoothly and continuously. The output voltage is kept stable and regulated constantly but there is a small transient effect as illustrated in Fig. 11.

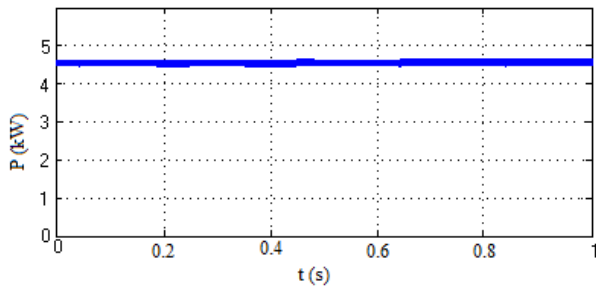

Fig. 10 PEMFC output power

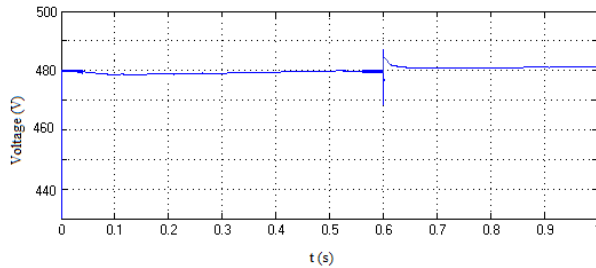

Fig. 11 System output voltage

The battery voltage is depicted in Fig. 12. From the graph, it can be seen that the battery will discharge and the terminal voltage will follow the load variation and fulfil the system requirement. It can be seen that the voltage is inversely proportional to the load current.

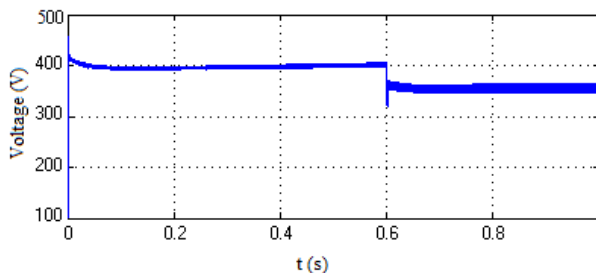

Fig. 12 Battery terminal voltage

V. CONCLUSION

A hybrid PEMFC and battery energy storage system for stand-alone DG configuration is developed and simulated using the MATLAB/Simulink software. Simulation results show that by applying MPPT unit to the model, the FC is able to operate at its MPP and the battery model is able to function as a back-up to follow the load variation. Analysis of results shows that the full system is able to utilize the FC maximum power and at the same time regulate the output voltage. Operation of FC at MPP and output voltage regulation is achieved by using two controllers which are the boost converter with MPPT controller and the bidirectional converter applying PI controller.

ACKNOWLEDGMENTS

This work was supported by Universiti Kebangsaan Malaysia under the research grant ERGS/1/2012/TK02/UKM01/3 and the Universiti Tun Hussein Onn Malaysia with the Ministry of Higher Education of Malaysia for financial support in terms of scholarship.

REFERENCES

- [1] J.M. Guerrero, F. Blaabjerg, T. Zhelev, K. Hemmes, E. Monmasson, S. Jemei, M. P. Comech, R. Granadino, and J. I Frau, "Distributed generation: toward a new energy paradigm," *Industrial Electronics Magazine, IEEE*, vol.4, pp.52-64, March 2010.
- [2] N.A. Zambri, A. Mohamed, and H. Shareef, "Performance comparison of dynamic models of proton exchange membrane and planar solid oxide fuel cells subjected to load change," *IREMOS*, vol. 4 no. 6, pp. 3402-3409, December 2011.
- [3] M.H. Nehrir, C. Wang, and S.R. Shaw, "Fuel cells: promising devices for distributed generation," *IEEE Power and Energy Magazine*, vol. 4, pp. 47-53, Jan-Feb 2006.
- [4] M.Y. El-Sharkh, A. Rahman, M.S. Alam, P.C. Byrne, A.A. Sakla, and T. Thomas, "A dynamic model for a stand-alone PEM fuel cell power plant for residential applications," *J. Power Sources*, vol. 138, pp. 199-204, November 2004.
- [5] N. Femia, G. Petrone, G. Spagnuolo and M. Vitelli, "Optimization of perturb and observe maximum power point tracking method," *IEEE Trans. Power Elect.*, vol. 20, pp. 963-973, July 2005.
- [6] A.M.A. Mahmoud, H.M. Mashaly, S.A. Kandil, H. ElKhashab and M.N.F. Nashed, "Fuzzy logic implementation for photovoltaic maximum power tracking," *Proceeding of the 26th Annual Conference of the IEEE International Workshop on Robot and Human Interactive Communication*, vol. 1, pp. 735-740, Oct. 2000.
- [7] R. Marouani, and F. Bacha, "A maximum-power-point-tracking algorithm applied to a photovoltaic water-pumping system," *Proceeding of the 8th International Symposium on Advanced Electromechanical Motion Systems and Electric Drives Joint Symposium*, vol. 1, pp: 1-6, Sept. 2009.
- [8] V. Zhiglov, G. Wenzhong, E. Muljadi, and G. Wang, "A new control strategy for stand-alone fuel cell-battery hybrid power supply system," *Power & Energy Society General Meeting*, vol. 1, pp.1-6, July 2009.

N. A. Zambri received her B.Sc. from Universiti Kebangsaan Malaysia in 2007 and M.Eng from Universiti Teknologi Malaysia in 2010, respectively. Currently, she is pursuing her PhD at Universiti Kebangsaan Malaysia. She can be reached at aira@uthm.edu.my.

A. Mohamed received her B.Sc from University of London in 1978 and M.Sc and PhD from Universiti Malaya in 1988 and 1995, respectively. She is a professor in the Department of Electrical, Electronic and Systems Engineering, Universiti Kebangsaan Malaysia. Her main research interests are power system security, power quality, artificial intelligence and renewable energy systems. She is a senior member of IEEE. She can be reached at azah@eng.ukm.my

H. Shareef received his B. Sc. with honours from IIT, Bangladesh, MS degree from METU, Turkey, and PhD degree from UTM, Malaysia, in 1999, 2002 and 2007, respectively. His current research interests are power system deregulation, power quality and power system distribution automation. He is currently a senior lecturer at the Department of Electrical, Electronic and Systems Engineering, University Kebangsaan Malaysia. He can be reached at shareef@eng.ukm.my.

M. Z. C. Wanik received his B. Sc. in Electrical Engineering from University of Evansville, Indiana, USA, M. Eng. Sc. in Electrical Utility Engineering from Curtin University of Technology, Australia, and PhD from University Duisburg-Essen, Germany respectively in 1997, 2002 and 2011. He is currently a lecturer at the Department of Electrical, Electronic and Systems Engineering, University Kebangsaan Malaysia. His current research interest is distributed generators integration to the electrical power system. He is a member of IEEE.