

Design of a Drift Assist Control System Applied to Remote Control Car

Sheng-Tse Wu, Wu-Sung Yao

Abstract—In this paper, a drift assist control system is proposed for remote control (RC) cars to get the perfect drift angle. A steering servo control scheme is given powerfully to assist the drift driving. A gyroscope sensor is included to detect the machine's tail sliding and to achieve a better automatic counter-steering to prevent RC car from spinning. To analysis tire traction and vehicle dynamics is used to obtain the dynamic track of RC cars. It comes with a control gain to adjust counter-steering amount according to the sensor condition. An illustrated example of 1:10 RC drift car is given and the real-time control algorithm is realized by Arduino Uno.

Keywords—Drift assist control system, remote control cars, gyroscope, vehicle dynamics.

I. INTRODUCTION

DRIFTING is a special driving skill for RC cars [1]. In this research, assuming RC car being a rigid body, the analysis of the planar and yaw motions during drifting is given. The main point is how to balance the force from drifting and correct steering control of front wheels [10]-[12], which is mostly determined by the slip angle (β) [5], [9] as shown in Fig. 1. This paper presents a drift assist control system to avoid RC cars out of control during drifting or a large sideslip [8]. Measuring the sideslip angle and controlling the steering of front wheels can make the RC car stable effectively.

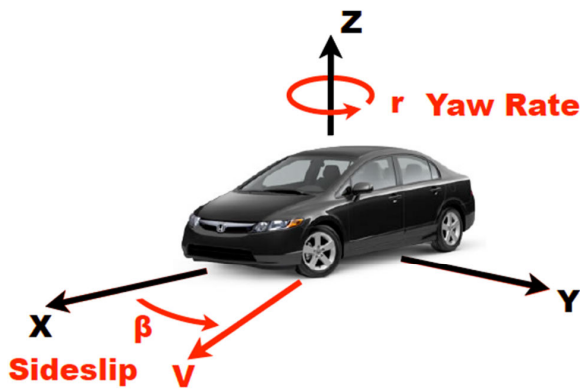

Fig. 1 Define the yaw rate and planar motion of a car on X, Y and Z axis [5]

Sheng-Tse Wu and Wu-Sung Yao are with the Department of Mechanical and Automation Engineering, National Kaohsiung First University of Science and Technology, No.1, University Rd., Yanchao Dist., Kaohsiung City 824, Taiwan (e-mail: wsyao@nkfust.edu.tw).

II. METHODS

A. Dynamics Analysis of the Vehicle

The primary motions for vehicle dynamics control are longitudinal, lateral, and yaw motions [2]-[4], or planar motion as shown in Fig. 2. It is easy to cause rear wheel's F_x and F_y overcoming tire's maximum frictional force with the slip angle (β) increasing. Therefore, the spinning of the vehicle will be generated.

The drifting dynamics includes the planar force and moment generating from front wheels' steer and rear wheels during the large sideslip. The longitudinal force is generated by the driving force, while the lateral force is generated by the front wheel steering. Assume that the moment is produced by the longitudinal and lateral forces of each tire. The longitudinal force (F_x), lateral force (F_y) and moment (M_z) equations acting on the center of gravity [13] are given as:

$$F_x = F_{xfr} \cos \delta_{fr} - F_{yfr} \sin \delta_{fr} + F_{xfl} \cos \delta_{fl} - F_{yfl} \sin \delta_{fl} + F_{xrr} \cos \delta_{rr} - F_{yrr} \sin \delta_{rr} + F_{xrl} \cos \delta_{rl} - F_{yrl} \sin \delta_{rl}$$

$$F_y = F_{yfr} \cos \delta_{fr} + F_{xfr} \sin \delta_{fr} + F_{yfl} \cos \delta_{fl} + F_{xfl} \sin \delta_{fl} + F_{yrr} \cos \delta_{rr} + F_{xrr} \sin \delta_{rr} + F_{yrl} \cos \delta_{rl} + F_{xrl} \sin \delta_{rl}$$

$$M_z = l_s(-F_{xfl} \cos \delta_{fl} + F_{yfl} \sin \delta_{fl} - F_{xrl} \cos \delta_{rl} + F_{yrl} \sin \delta_{rl}) + l_s(F_{xfr} \cos \delta_{fr} - F_{yfr} \sin \delta_{fr} + F_{xrr} \cos \delta_{rr} - F_{yrr} \sin \delta_{rr}) + l_f(F_{yfl} \cos \delta_{fl} + F_{xfl} \sin \delta_{fl} + F_{yfl} \cos \delta_{fr} + F_{xfr} \sin \delta_{fr}) - l_f(F_{yrl} \cos \delta_{rl} + F_{xrl} \sin \delta_{rl} + F_{yrr} \cos \delta_{rr} + F_{xrr} \sin \delta_{rr})$$

B. Experimental Setup

The RC car structure is shown in Fig. 3, which consists of Controller board with Arduino Uno (7) driven by the 9V battery (8) and interfaced with MPU6050 gyroscope (5), servo motor (6), front axle (4) for front wheel steer mechanism, rear axle (1), and the brushless motor (2) driven by the 7.4V battery (3).

C. Control Method

The proposed control system is implemented by Arduino Uno, which is obtained by the block diagram in Fig. 4. The sensor MPU6050 gyroscope is used to detect the slip angle, and return the data of yaw axis to Arduino Uno. Via the algorithm, the data will be scaled by the Pulse Width Modulation (PWM) signal, which can be used to control the servo motor rotating on correct position immediately.

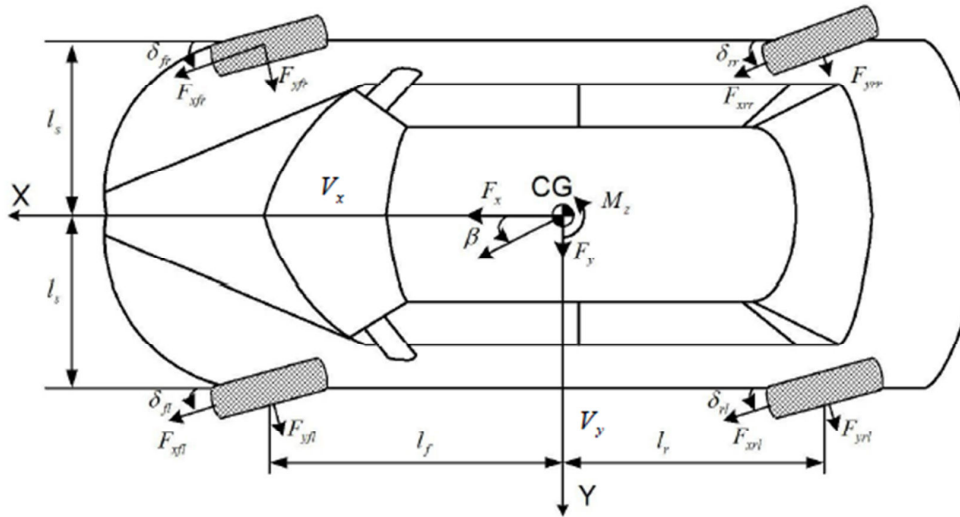

Fig. 2 Forces and moments generating on vehicle during drifting [6]

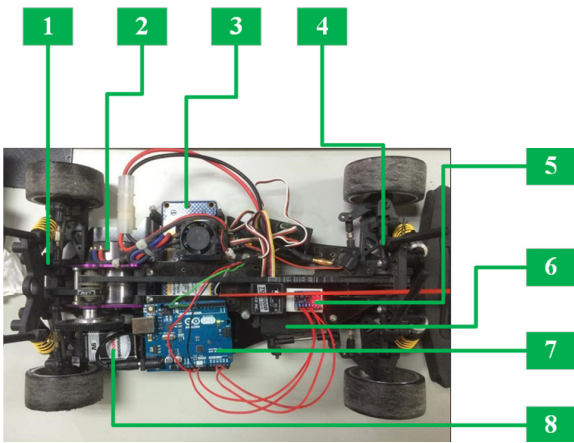

Fig. 3 Experimental setup for the drift assist control system

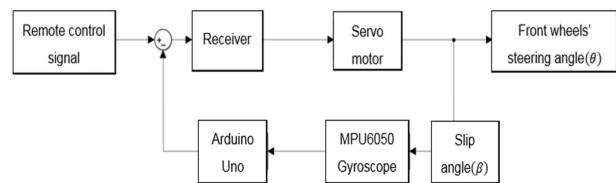

Fig. 4 Control block diagram of the drift assist control system

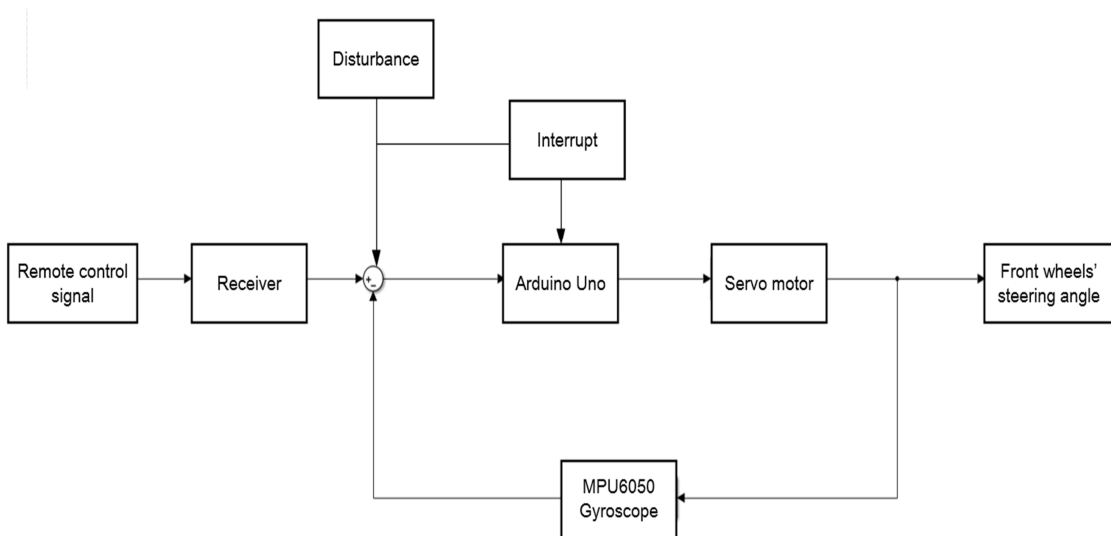

Fig. 5 Improved control block diagram of Fig. 4

The RC car in general condition is always driven by user. This drift assist control system only works at the point, when the RC car will spin during drifting. But the PWM signal from Arduino Uno will conflict the PWM signal from the RC. Therefore, in order to let the PWM signal from Arduino Uno can exactly control the front wheel in counter-steer and not interfered by the signal from RC. Using the interrupted method with Arduino Uno can prevent the PWM signal of RC from inputting the servomotor when the RC car is on the critical point, i.e., going to spin during drifting. Therefore, the control method of Fig. 4 can be rewritten as shown in Fig. 5.

D. Steer Module

In general, the PWM pulse's width is given between $1100\mu s$ and $1900\mu s$ [7]. In this paper, the width of PWM is used to determine the range of the servo's angular motion. Figs. 6-8 acquired by the oscilloscope are used to show the PWM signals with servo motor motion. A servo pulse of $1500\mu s$ is used to set the servo to its neutral position, or 90° steer as shown in Fig. 6. Pulse width less than $1500\mu s$ is given to set position right to the neutral or physically limited maximum right steer (45°) as shown in Fig. 7 and pulse width more than $1500\mu s$ is used to set position left to neutral or physically limited maximum left steer (135°) as shown in Fig. 8. The input voltage V_{cc} ($3.3V$) in Fig. 9 is supplied by the battery in RC. The output voltage V_o can be varied by the variable resistor, i.e., $\frac{R_2}{R_1 + R_2} \times V_{cc}$. In the control realization, V_o can be converted to the digital signal by the analog-to-digital converter (A/D), and using the microcontroller generates PWM. Table I shows the experimental parameters of rotating angle, voltage V_o , A/D, and PWM with the servo turning right. That of the servo turning left in this case is shown in Table II. Fig. 10 shows the linear relationship of A/D and PWM.

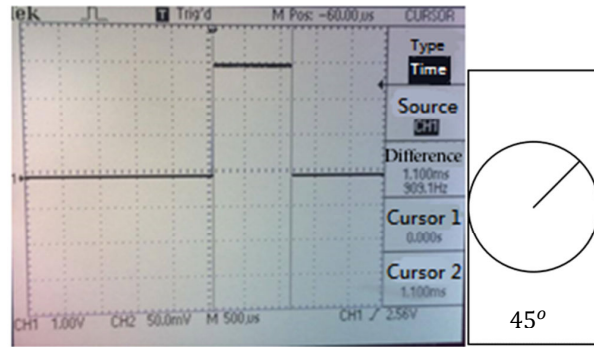

Fig. 7 PWM signal measured by oscilloscope when the servo motor being on the position of limited maximum right steer (45°)

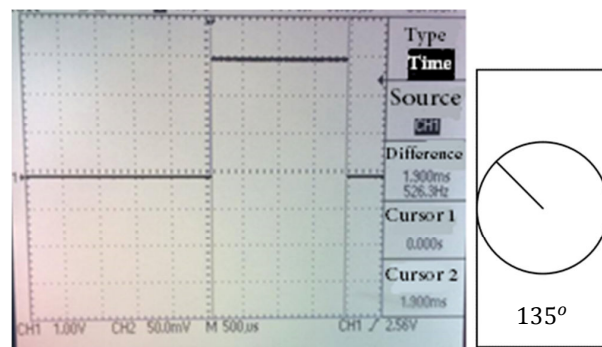

Fig. 8 PWM signal measured by oscilloscope when the servo motor being on the position of limited maximum left steer (135°)

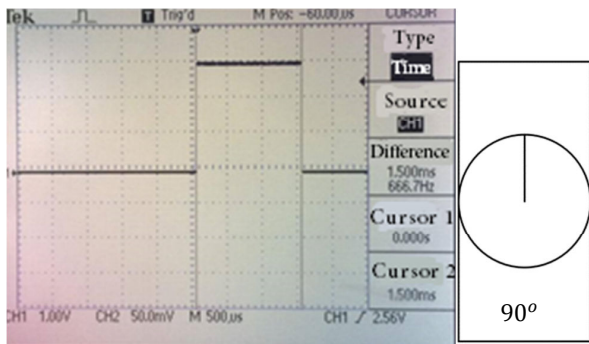

Fig. 6 PWM signal measured by oscilloscope when the servo motor being on the neutral position (90°)

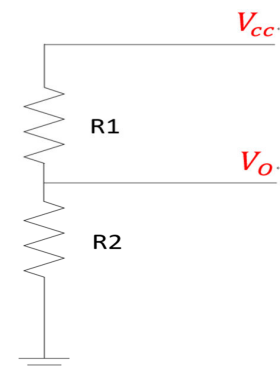

Fig. 9 Variable resistor's circuit diagram in the RC

TABLE I
THE RELATIONSHIP OF ROTATING ANGLE (θ), VOLTAGE (V_o), A/D AND PWM WHEN THE SERVO TURNING RIGHT

θ	45°	54°	63°	72°	81°	90°
R1 (k Ω)	3.88	3.41	3.15	2.85	2.5	2.35
R2 (k Ω)	1.04	1.34	1.6	1.93	2.24	2.64
V_o	0.69756	0.93095	1.11157	1.33242	1.49635	1.74589
A/D	216.2436	288.5945	344.5867	413.0502	463.8685	541.2259
PWM (μs)	1100	1180	1260	1340	1420	1500

TABLE II
THE RELATIONSHIP OF ROTATING ANGLE (θ), VOLTAGE (V_o), A/D AND PWM WHEN THE SERVO TURNING LEFT

θ	90°	99°	108°	117°	126°	135°
R1 (k Ω)	2.35	1.96	1.6	1.29	0.98	0.8
R2 (k Ω)	2.64	2.86	3.15	3.48	3.81	40.8
V_o	1.74589	1.95809	2.18842	2.40755	2.62484	2.75902
A/D	541.2259	607.0079	678.4102	746.3405	813.7004	855.2962
PWM (μs)	1500	1580	1660	1740	1820	1900

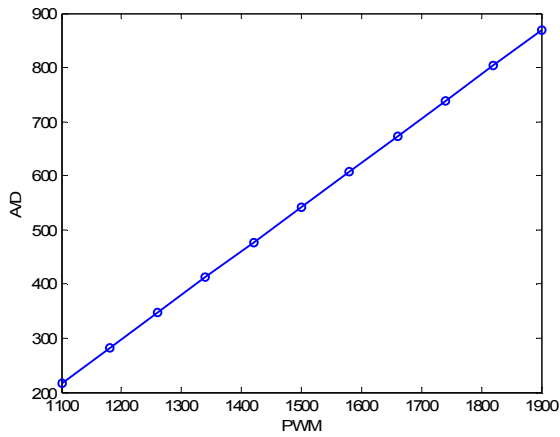
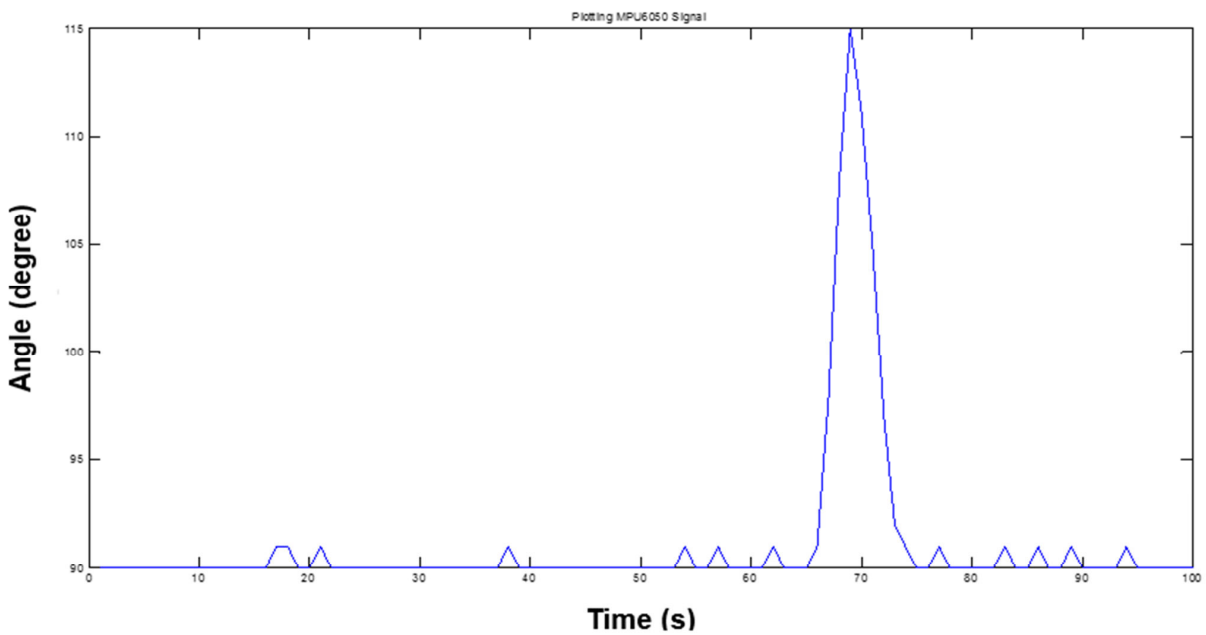

Fig. 10 The linear relationship of A/D and PWM

III. RESULTS

Using the gyroscope detects the slip angle and controlling the rotation angle of the servo motor, the experimental results are shown in Figs. 11 and 12. Based on different slip angle, the servo motor makes the front wheels to generate the correspondent steering angle. Figs. 11 (a) and 12 (a) show the servo motor's rotation angle converted by slip angle via the algorithm. Figs. 11 (b) and 12 (b) show the actual steering situation of front wheels. The time responses of MPU6050 gyroscope and the Arduino Uno can satisfy the required performance to achieve the goal of the steering angle. Even the RC car moving around the continuous curves with high speed, the drift assist control system can keep the car having traction and drifting more smoothly.



(a)



(b)

Fig. 11 (a) Servo motor's left rotation angle 25 degrees, and (b) servo motor making front wheels turn left with the correspondent steering angle

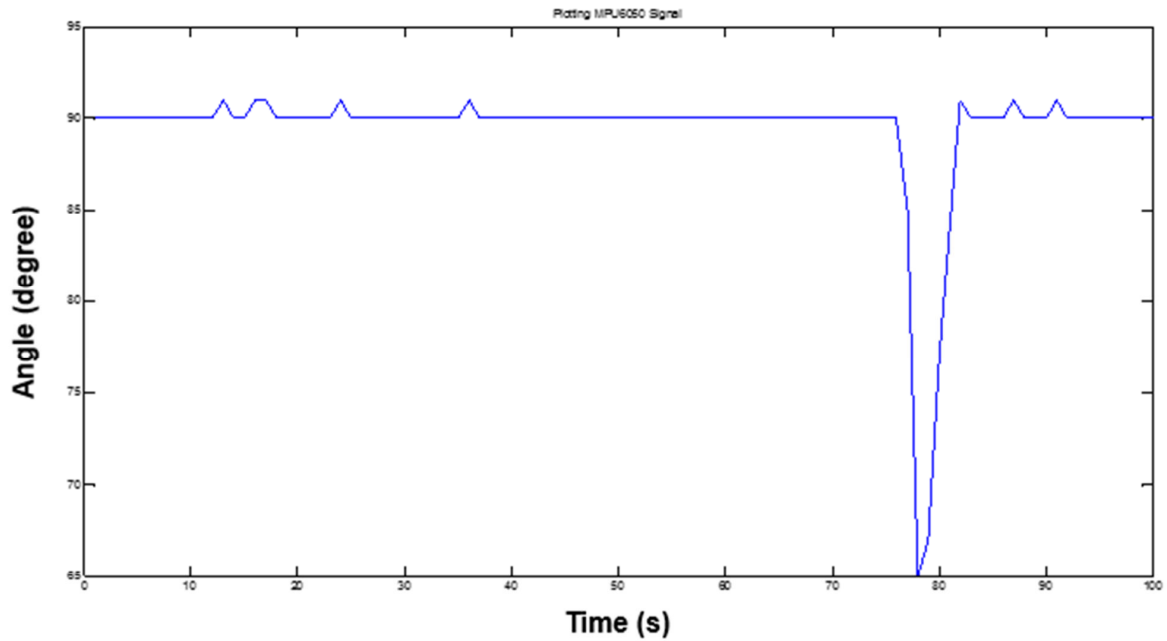

(a)



(b)

Fig. 12 (a) Servo motor's right rotation angle 25 degrees, and (b) servo motor making front wheels turn right with the correspondent steering angle

IV. DISCUSSION AND FUTURE SCOPE

Via the dynamic analysis of the drifting, this study can realize the method to control the steering of front wheels to counter balance the force that produced by drift. Using the gyroscope, the immediate information can be obtained by the car and calculate the optimal time to make the car come back to the normal traction. The results show that the proposed control system can be applied to RC drift car and make it drift more smoothly.

The difference of drifting and spinning is whether controlling the steering of front wheels to counter balance the force from spinning. In recent years, more active safety systems have been developed, such as vehicle stability assist, vehicle

stability control, and electronic stability program. These systems are used to keep vehicle having the traction on different pavements. It uses many sensors to detect speed of each wheel, steering angles and yaw rate. Besides, it can prevent vehicle from spinning when going through the low friction surface roads with controlling the engine power and brake force distribution. However, it cannot be applied to the large angle sideslip. Via controlling the steering of front wheels to counter balance the force from sideslip, the drift assist control system can efficiently stabilizes the vehicle and provides the normal active safety system.

REFERENCES

- [1] M. Abdulrahim. 2006. "On the Dynamics of Automobile Drifting," SAE Technical Paper 2006-01-1019, doi: 10.4271/2006-01-1019.
- [2] E. Velenis, D. Katzourakis, E. Frazzoli, P. Tsiotras and R. Happee. 2011. "Steady-state drifting stabilization of RWD vehicles," Control Engineering Practice, Elsevier.
- [3] G. Baffet, A. Charara and D. Lechner. 2009. "Estimation of vehicle sideslip, tire force and wheel cornering stiffness," Control Engineering Practice, Elsevier.
- [4] G. Baffet, A. Charara and D. Lechner. 2007. "Experimental evaluation of tire-road forces and sideslip angle observers," Control Conference (ECC), European, Kos, Greece.
- [5] R. Y. Hindiyeh. 2013. "Dynamics and Control of Drifting in Automobiles," PhD dissertation. California: Stanford University, U.S.A.
- [6] J. Wang and R. G. Longoria. 2007. "Coordinated and Reconfigurable Vehicle Dynamics Control," PhD dissertation. Austin: The University of Texas at Austin, U.S.A.
- [7] K.R.Radhakrishnan D.Sivaraj, A.Kandaswamy and S.Dinesh J.Prithiviraj. 2011. "Design of Automatic Steering Control and Adaptive Cruise Control of Smart Car," IJCA Proceedings on International Conference on VLSI, Communications and Instrumentation (ICVCI).
- [8] C. Vosera, Rami Y. Hindiyeh and J. Christian Gerdes. 2009. "Analysis and control of high sideslip maneuvers," in 21st International Symposium on Dynamics of Vehicles on Roads and Tracks, Stockholm, Sweden.
- [9] Y. H. Judy Hsu and J. Christian Gerdes. 2008. "The predictive nature of pneumatic trail: Tire slip angle and peak force estimation using steering torque," in International Symposium on Advanced Vehicle Control, Kobe, Japan.
- [10] J. Edelman and M. Plöchl. 2009. "Handling characteristics and stability of the steady-state powerslide motion of an automobile," Regular and Chaotic Dynamics, vol. 14, no. 6, pp. 682-692
- [11] E. Velenis, E. Frazzoli and P. Tsiotras. 2010. "Steady-state cornering equilibria and stabilization for a vehicle during extreme operating conditions," International Journal of Vehicle Autonomous Systems, Special Issue on Autonomous and Semi-Autonomous Control for Safe Driving of Ground Vehicles, vol. 8, no. 2/3, pp. 217-241
- [12] E. Velenis, E. Frazzoli and P. Tsiotras. 2009. "On steady-state cornering equilibria for wheeled vehicles with drift," in 48th IEEE Conference on Decision and Control, Shanghai, China.
- [13] E. Bakker, L. Nyborg, and H. Pacejka. 1987. "Tyre modelling for use in vehicle dynamics studies," SAE Paper No. 870421.