

Design and Simulation of CCM Boost Converter for Power Factor Correction Using Variable Duty Cycle Control

M. Nirmala

Abstract—Power quality in terms of power factor, THD and precisely regulated output voltage are the major key factors for efficient operation of power electronic converters. This paper presents an easy and effective active wave shaping control scheme for the pulsed input current drawn by the uncontrolled diode bridge rectifier thereby achieving power factor nearer to unity and also satisfying the THD specifications. It also regulates the output DC-bus voltage. CCM boost power factor correction with constant frequency operation features smaller inductor current ripple resulting in low RMS currents on inductor and switch thus leading to low electromagnetic interference. The objective of this work is to develop an active PFC control circuit using CCM boost converter implementing variable duty cycle control. The proposed scheme eliminates inductor current sensing requirements yet offering good performance and satisfactory results for maintaining the power quality. Simulation results have been presented which covers load changes also.

Keywords—CCM Boost converter, Power factor Correction, Total harmonic distortion, Variable Duty Cycle.

I. INTRODUCTION

IN recent years, the demand for energy is increasing rapidly and with the rapid development of power electronics technologies, usage of power electronic system has been expanded to a wide range of applications that include residential, industrial, commercial, and aerospace and traction systems. Most of the electrical and electronic appliances such as laptops, desktops, SMPS, UPS, and VFD work on D.C supply. Designing D.C power supplies for such applications is extremely.

AC to DC converter or rectifier is a device that converts ac to dc. This conversion is done by switching devices such as diodes, Thyristors, power MOSFET's, etc. AC to DC converter consisting of line frequency diode with a large output filter capacitor is cheap and robust but very inefficient. Due to the non linear behavior of the switches they tend to draw highly distorted input current in short bursts or spikes relative to the line voltage. As a result input power factor becomes very poor and also produces a large spectrum of harmonic signals that may interfere with other equipments. Low power factor results in poor output voltage regulation, increased current and therefore losses requiring utility source equipment, such as transformers and switchgears to have

higher VA ratings. Moreover utilities will charge a higher cost to industrial and commercial clients having a low P.F. Thus overall efficiency of the system is degraded.

A variety of passive and active PFC techniques have been proposed. Passive PFC techniques incorporating L and C components are the best choice for linear loads [1]. But for nonlinear loads active PFC techniques are preferred due to their superior performance. Some of the topologies widely used for active PFC are buck, boost and buck-boost [2], [3]. Buck and Buck-boost converters produces pulsed input current requiring additional filtering. The fundamental property of the boost converter is to produce a smooth input current waveform enough to meet Total Harmonic Distortion (THD) specifications for the input current. This results in much less EMI and therefore reduced filtering requirements. For these reasons, the boost PFC circuit operating in continuous-conduction mode (CCM) is, by far, the popular choice for medium- and high-power applications [4].

Whether analog or digital control, the boost PFC converter implements two control loops—a voltage loop and a current loop [5], [6]. The objective of voltage loop is to regulate the output voltage of boost converter. In contrast, the objective of current loop is to make the supply current to follow the sinusoidal waveform of the supply voltage, providing high power factor (PF) and low total harmonic distortion (THD). Current control loop implements average, peak or hysteresis current control. These control methodologies are most widely used by researchers in the study and implementation of front end converters for power factor correction.

The unity PF for DCM boost PFC converter with constant-switching frequency can be achieved by the variable-duty-cycle control scheme. This method requires complex analog circuit implementation [7]-[10]. If DCM mode is applied the input current is normally a train of triangle pulses with nearly constant duty ratio. Additional input filter is necessary for smoothing the pulsating input current to a continuous one. To ensure high power factor, the average current of the pulsating current should follow the input voltage in both shape and phase. This paper presents digital implementation of variable duty cycle control with constant switching frequency for CCM boost PFC converter which covers load changes also. Simulation results shows that the power factor and THD obtained meets proposed standards such as IEC 61000-3-2.

M.Nirmala was with the School of Electrical and Electronics Engineering, SASTRA University, Tirumalaisamudram, Thanjavur- 613401, Tamilnadu, India (e-mail: nirmala58ece@gmail.com).

II. BOOST PFC CONVERTER WITH VARIABLE DUTY CYCLE CONTROL

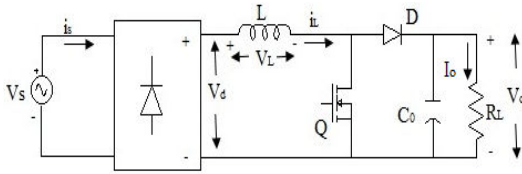

Fig. 1 Main circuit of boost PFC converter

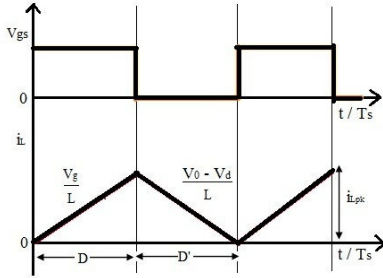

Fig. 2 Inductor current waveform for DCM operation

For simplicity, the following assumptions are made: 1) All the devices and components are ideal; 2) the ripple of the output voltage is too small to be neglected; and 3) the switching frequency is much higher than the line frequency.

Supposing that source voltage is purely sinusoidal and free from distortion, source voltage is defined as,

$$V_s(t) = V_p \sin \omega t \quad (1)$$

where, V_p is the peak value of the source voltage and ω is the angular frequency of the source voltage.

The rectified voltage is given as,

$$V_d = V_p |\sin \omega t| \quad (2)$$

Fig. 2 shows the inductor current waveform in a switching cycle for DCM operation of the converter. The inductor peak current is,

$$i_{Lpk}(t) = \frac{V_d}{L} D_y T_s = \frac{V_p |\sin \omega t|}{L} D_y T_s \quad (3)$$

where, D_y is the duty cycle corresponding to the ON time of the switch; T_s is switching period.

In a switching cycle, the inductor has a volt-second balance, i.e.,

$$V_d D_y T_s = (V_0 - V_d) D_r T_s \quad (4)$$

D_r is the duty cycle corresponding to the OFF time of the switch; V_0 is the output voltage of the boost converter

Equation (4) can be written as,

$$D_r = \frac{V_d}{V_0 - V_d} D_y = \frac{V_p |\sin \omega t|}{V_0 - V_p |\sin \omega t|} D_y \quad (5)$$

From (3) and (5) average inductor current is derived as,

$$i_{Lavg}(t) = \frac{1}{2} i_{Lpk}(t) (D_y + D_r) = \frac{V_p D_y^2}{2 L f_s} \frac{\sin \omega t}{1 - \frac{V_p}{V_0} |\sin \omega t|} \quad (6)$$

where, $f_s = \frac{1}{T_s}$ is the switching frequency

Thus the supply current is,

$$i_s(t) = \frac{V_p D_y^2}{2 L f_s} \frac{\sin \omega t}{1 - \frac{V_p}{V_0} |\sin \omega t|} \quad (7)$$

where, D_y is constant.

Fig. 3 shows that the envelope of the peak value of inductor current is sinusoidal. However the envelope of the average value of inductor current is not sinusoidal and contains distortion it. For analysis purpose the average inductor current is normalized with the base of $(V_m D_y^2 / 2 L f_s) (1 / (1 - V_m / V_0))$, so (7) is rewritten as

$$i_s^* = (1 - \frac{V_p}{V_0}) \frac{\sin \omega t}{1 - \frac{V_p}{V_0} |\sin \omega t|} \quad (8)$$

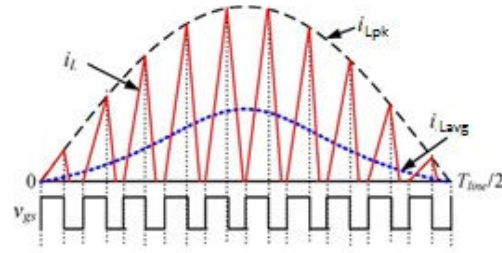

Fig. 3 Inductor waveform in a half line cycle

Assume 100% efficiency for the converter, i.e., $P_{in} = P_0$, the duty cycle is

$$D_y = \frac{1}{V_m} \sqrt{\frac{2\pi L f_s P_0}{\int_0^\pi \frac{\sin^2 \omega t}{1 - \frac{V_p}{V_0} |\sin \omega t|} d\omega t}} \quad (9)$$

III. VARIABLE DUTY CYCLE CONTROL TO IMPROVE THE INPUT PF

In (9) D_y is assumed to be constant. In order to achieve power factor nearer to unity D_y is assumed to be variable as follows

$$D_y = D_0 \sqrt{1 - \frac{V_p}{V_0} |\sin \omega t|} \quad (10)$$

D_0 is the coefficient which will be explained later.

Substitution of (10) into (7) leads to

$$i_s(t) = \frac{V_p D_0^2 \sin \omega t}{2 L f_s} \quad (11)$$

Assuming 100% efficiency for the converter the average input power is derived as

$$P_{in} = \frac{1}{2} V_m \frac{V_m D_0^2}{2L f_s} = \frac{V_m^2 D_0^2}{4L f_s} = P_o \quad (12)$$

From (12) D_0 is obtained as

$$D_0 = 2 \sqrt{\frac{P_o L f_s}{V_m}} \quad (13)$$

Substitution of (13) into (10) leads to

$$D_y = \frac{2\sqrt{L f_s P_o}}{V_p} \sqrt{1 - \frac{V_p}{V_0} |\sin \omega t|} = \frac{2\sqrt{L f_s P_o}}{V_p} \sqrt{1 - \frac{V_p}{V_0}} \quad (14)$$

A. Fitting Duty Cycle

The Duty cycle expressed in (14) is complicated to implement because a multiplier, a divider and a square root extractor are needed. It can be simplified as follows

Assuming $a = V_m/V_0$; $y = |\sin \omega t|$, (10) can be rewritten as,

$$D_y = D_0 \sqrt{1 - ay} \quad (15)$$

Based on Taylor's series

$$f(x) = f(x_0) + f'(x_0) + \frac{1}{2!} f''(x_0)(x - x_0)^2 + \dots + \frac{1}{n!} f^{(n)}(x_0)(x - x_0)^n + \dots \quad (16)$$

Equation (15) can be expressed as

$$D_y = D_0 \left[\sqrt{1 - ay} - \frac{a}{2} (1 - ay_0)^{-\frac{1}{2}} (y - y_0) - \frac{1}{2!} \frac{a^2}{4} (1 - ay_0)^{-\frac{3}{2}} (y - y_0)^2 + \dots \right] \quad (17)$$

Reserving only first derivative term, (17) is approximated as

$$D_{y_fit} = D_0 \left[\sqrt{1 - ay} - \frac{a}{2} (1 - ay_0)^{-\frac{1}{2}} (y - y_0) \right] = D_1 \left(1 - \frac{a}{2 - ay_0} y \right) \quad (18)$$

where, $D_1 = (D_0(2 - ay_0)) / (2\sqrt{1 - ay_0})$

The value for y_0 should be chosen such that it enables the maximum input PF at the highest input voltage. This value is obtained by substituting $a = 264\sqrt{2}/400$ in PF equation derived in [10] and then differentiating it with y_0 and setting it to zero, $y_0 = 0.866$ is obtained. Substituting a and $y_0 = 0.866$ into (18), the duty cycle can be simplified as,

$$D_{y_fit} = D_1 \left(1 - \frac{V_m |\sin \omega t|}{2V_0 - 0.866V_m} \right)$$

$$D_{y_fit} = D_1 \frac{2V_0 - 0.866V_m - V_m |\sin \omega t|}{2V_0 - 0.866V_m} \quad (19)$$

IV. CCM BOOST PFC CONVERTER

Equation (19) shows duty cycle equation using variable duty cycle control which governs the switching of MOSFET for the Boost converter. It clearly shows that duty cycle

depends only on boost converter's output voltage, rectifier's output voltage and its peak value thus eliminating current sensing requirements. Closed loop using variable duty cycle can be implemented using analog or digital control. In analog control, multiplication, division operation involved in the equation & the compensation requirements are implemented using op-amp. Pulses for the switch are obtained using PWM IC UC3525. But in digital control all these functions can be implemented using a simple low cost microcontroller

V. SIMULATION RESULTS

Fig. 4 shows the Matlab simulations of CCM boost PFC converter with variable duty cycle control. Design specifications considered are Peak voltage, $V_{peak} = 245$ Vac; Output voltage, $V_{out} = 18$ Vdc; Switching frequency, $f_s = 20$ kHz; Inductor, $L_{(ccm)} = 40$ uH; Load resistance, $R_L = 100 - 1000 \Omega$. A step down transformer is used here to step down primary $V_{peak} = 245$ Vac to secondary $V_{peak} = 12$ Vac. It serves as input for diode bridge rectifier and then the rectified voltage is boosted using boost converter. It clearly shows that only diode bridge rectifier's output voltage and boost converter's output voltage is sensed for closed loop control thus eliminating the inductor current sensing requirements. Fig. 5 shows waveform for Boost converter's output voltage. V_{out} is maintained to a constant value of 18V. Fig. 6 shows supply current waveform of the rectifier. This control technique shapes the distorted input current waveform to a sinusoidal shape resulting in reduced harmonics thereby meeting the standards. Fig. 7 shows the waveform comparing both supply current and supply voltage. Fig. 8 shows the THD measurement for the input current. For $R_L = 100 \Omega$, $THD = 1.91\%$ and $PF = 0.9997$ is obtained. By implementing this control technique active wave shaping for supply current is achieved and it follows the same shape as that of supply voltage.

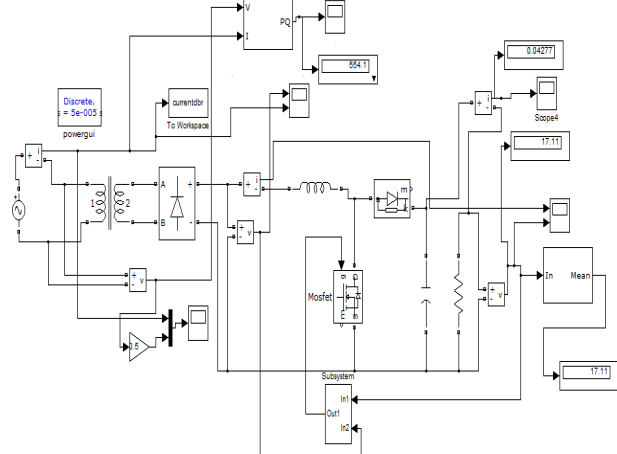

Fig. 4 CCM Boost PFC converter using variable duty cycle control

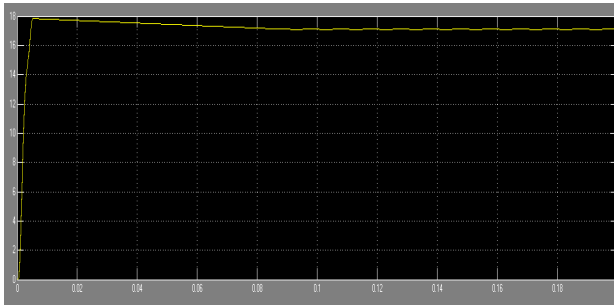

Fig. 5 Waveform showing Boost converter's output voltage

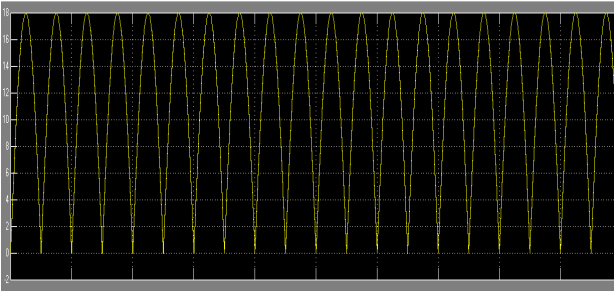

Fig. 6 Waveform showing supply current

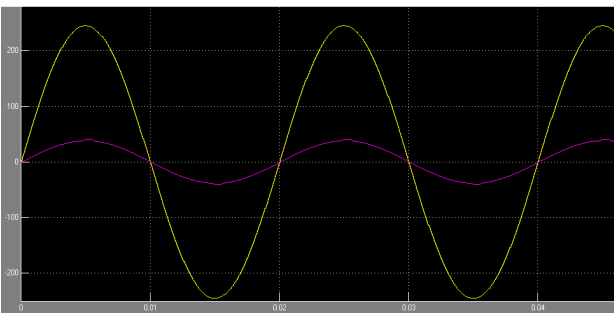

Fig. 7 Waveform showing supply current and supply voltage

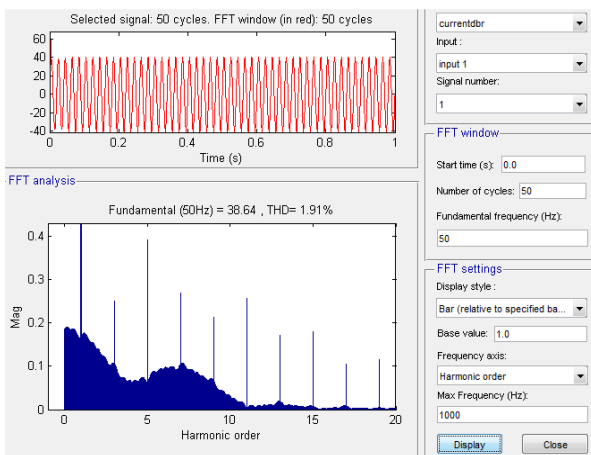

Fig. 8 THD measurement for input current

TABLE I
MEASUREMENTS OF OUTPUT VOLTAGE, PF, THD FOR LOAD VARIATIONS

$R_L(\Omega)$	V_{out} (vdc)	PF	THD(%)
100	17.06	0.998	1.32
200	17.09	0.998	1.06
400	17.1	0.998	0.8
600	17.11	0.997	0.93
800	17.12	0.998	0.93
1000	17.13	0.998	0.93

Table I shows the tabulation of Output voltage, V_{out} , Power factor, PF , Total harmonic distortion, THD by varying load resistance. In spite of these variations all the above mentioned parameters are maintained thus complying with standards.

VI. CONCLUSION

This paper implements variable duty cycle control for CCM Boost PFC converter. It differs from the conventional power factor correction techniques by eliminating inductor current sensing requirements. CCM mode is chosen which features smaller inductor current ripple resulting in low RMS currents on inductor and switch thus leading to low electromagnetic interference. By this technique supply current is made to follow supply voltage effectively. Thus the input power factor for diode bridge rectifier is improved and harmonic content in the supply current is reduced. It complies with standards for Total Harmonic distortion. In addition it also maintains output voltage regulation. All these together offer a satisfactory performance. Simulation results were presented for this technique which covers load variation also.

REFERENCES

- [1] O. Garcia, J. A. Cobos, R. Prieto, P. Alou, and J. Uceda, "Single Phase Power Factor Correction: A Survey," *IEEE Trans. Power Electron.*, vol. 18, no. 3, pp. 749–755, May
- [2] Z. Yang and P. C. Sen, "Recent Developments in High Power Factor Switch Mode Converters," in *Proc. IEEE Can. Conf. Elect. Comput. Eng.*, 1998, pp. 477–488.
- [3] Haipeng Ren, Tamotsu Ninomiya, "The Overall Dynamics of Power-Factor-Correction Boost Converter", IEEE, 2005.
- [4] Huai Wei, IEEE Member, and Issa Batarseh, IEEE Senior Member, "Comparison of Basic Converter Topologies for Power Factor Correction, IEEE, 1998.
- [5] Zhen Z. Ye, Milan M. Jovanovic and Brian T. Irving."Digital Implementation of A Unity-Power-Factor Constant – Frequency DCM Boost Converter", IEEE, 2005
- [6] A. Karaarslan, I. Iskender, "The Analysis of Ac-Dc Boost PFC Converter Based On Peak and Hysteresis Current Control Techniques, International Journal on Technical and Physical Problems of Engineering, June 2011.
- [7] Wei-Hsin Liao, Shun-Chung Wang, and Yi-Hua Liu, *Member, IEEE*, "Generalized Simulation Model for a Switched-Mode Power Supply Design Course Using Matlab/Simulink", IEEE Transactions on Education, vol. 55, No. 1, February 2012.
- [8] J. Lazar and S. Cuk, "Open Loop Control of a Unity Power Factor, Discontinuous Conduction Mode Boost Rectifier," in *Proc. IEEE INTELEC*, 1995, pp. 671–677.
- [9] K. Taniguchi and Y. Nakaya, "Analysis and Improvement of Input Current Waveforms for Discontinuous-Mode Boost Converter with Unity Power Factor," in *Proc. IEEE Power Convers. Conf.*, 1997, pp. 399–404.
- [10] Kai Yao, Xinbo Ruan, *Senior Member, IEEE*, Xiaojing Mao, and Zhihong Ye, "Variable-Duty-Cycle Control to Achieve High Input Power Factor for DCM Boost PFC Converter", IEEE Transactions on Industrial Electronics, vol. 58, no. 5, May 2011.