

# Design and Implementation of a Hybrid Fuzzy Controller for a High-Performance Induction Motor

M. Zerikat, and S. Chekroun

**Abstract**—This paper proposes an effective algorithm approach to hybrid control systems combining fuzzy logic and conventional control techniques of controlling the speed of induction motor assumed to operate in high-performance drives environment. The introducing of fuzzy logic in the control systems helps to achieve good dynamical response, disturbance rejection and low sensibility to parameter variations and external influences. Some fundamentals of the fuzzy logic control are preliminary illustrated. The developed control algorithm is robust, efficient and simple. It also assures precise trajectory tracking with the prescribed dynamics. Experimental results have shown excellent tracking performance of the proposed control system, and have convincingly demonstrated the validity and the usefulness of the hybrid fuzzy controller in high-performance drives with parameter and load uncertainties. Satisfactory performance was observed for most reference tracks.

**Keywords**—Fuzzy controller, high-performance, induction motor, intelligent control, robustness.

## I. INTRODUCTION

**D**UE to the recent advances in power electronic devices and microprocessors, high performance control and estimation for induction motor are very fascinating and a new alternative in robotics and mechatronic A.C drives [1]-[3]. This induction motor has many chances for application in controlled drives due to its inherent low cost, simplicity, high torque per volume and useful flux-weakening capability. However, high-performance industrial applications such as steel mills, robotics, machine tools, and electric vehicles, their control remains a challenging problem because they exhibit significant non-linearities and many of the parameters, mainly the rotor resistance vary with the operating conditions today [8]-[9].

The motor flux and motor speed can be controlled independently. FOC methods are attractive but suffer from one major disadvantage. Field orientation control FOC of induction motor is one the most important topics in the variable speed drive area. They are sensitive to plant

parameters variations and an incorrect flux measurement or estimation peed at low speed. One of the possible approach to robustly control in the case of plant uncertainties and unknown external disturbances is the application of modern control method such artificial intelligence techniques. Therefore, desired to develop a controller that has the ability to adjust its own parameters and even structure online, according to the environment in which it works to yield satisfactory control performance. An interesting alternative that could be investigated is the use of fuzzy logic control strategy. In the last decade, FLC has attracted considerable attention as a tool for a novel control approach because of the variety of advantages that it offers over the classical control techniques. In recent years, FLC was proposed for high-performance drives employing induction, synchronous reluctance and conventional DC machines [4]-[7]-[9]. Conventional control techniques require accurate mathematical models describing the dynamics of the system under study. These techniques result in tracking error when the load varies fast and overshoot during transients [4]-[5]. In this paper, a hybrid control system combining fuzzy logic and conventional control techniques, is proposed and applied to high-performance tracking of an induction motor. The paper is structured as follows. Section 2 describes a mathematical of induction motor drive; Section 3 gives the structure of the proposed hybrid fuzzy system. The basic concepts of the fuzzy sun-sets theory and the configuration of the control system are discussed in section 4, 5. Sections 6 and 7 provide the simulation results and conclusions, respectively.

## II. INDUCTION MOTOR DIFFERENTIAL EQUATIONS

The dynamics of the induction motor in the  $d-q$  motor reference frame fixed to the stator has a form of the following nonlinear differential equations (Morini, Peseda and Valogy, 1993).

Manuscript is received December 4, 2006

M. Zerikat is with the Department of Electrical and Computer Engineering, Laboratory of Automatic and Analysis Systems, Higher School of ENSET, Oran, Algeria (phone: +213 41 41 97 16; fax: +231 41 41 98 06; e-mail: mokhtar.zerikat@enset-oran.dz).

S. Chekroun is with the Department of Electrotechnics, Faculty of Electrical Engineering, University of Sciences and Technology UST, Oran-Algeria (e-mail: Chebrounsouf@yahoo.fr).

$$\frac{d}{dt} \begin{bmatrix} i_{ds} \\ i_{qs} \\ \psi_{rd} \\ \psi_{rq} \\ \omega_r \end{bmatrix} = \begin{bmatrix} -\frac{R_s L_r^2 - R_r L_m^2}{\sigma L_s L_r} \omega_e & \frac{R_r L_m}{\sigma L_s L_r} & \omega_r \frac{L_m}{\sigma L_s L_r} \\ -\frac{R_s L_r^2 - R_r L_m^2}{\sigma L_s L_r} -\omega_e & \frac{R_r L_m}{\sigma L_s L_r} & -\omega_r \frac{L_m}{\sigma L_s L_r} \\ R_r \frac{L_m}{L_r} & 0 & -\frac{R_r}{L_r} (\omega_e - \omega_r) \\ 0 & R_r \frac{L_m}{L_r} & -\frac{R_r}{L_r} (\omega_e - \omega_r) \\ p \frac{L_m}{J L_r} (\psi_{rd} i_{sq} - \psi_{rq} i_{sd}) - \frac{1}{J} T_L \end{bmatrix} + \begin{bmatrix} \frac{L_r}{\sigma L_s L_r} v_{sd} \\ \frac{L_r}{\sigma L_s L_r} v_{sq} \\ 0 \\ 0 \\ 0 \end{bmatrix} \quad (1)$$

where  $\sigma = 1 - \frac{L_m^2}{L_s L_r}$

$i_s, v_s, \psi_s, R, L$  denote the stator current and voltage vector components, the rotor flux linkage, resistance and inductance respectively. The subscripts s and r stand for stator and rotor, d and q are the components of a vector with respect to a synchronously rotating frame.  $\omega_e, \omega_r$  are the angular speed of coordinate system and the angular speed of rotor shaft respectively.  $\sigma$  is the dispersion coefficient, p denotes the number of pole pairs, J is the total rotor inertia and  $T_L$  is the load torque.

III. PROPOSED HYBRID FUZZY CONTROL SYSTEM

The conventional controllers, such as the Proportional Integral and Derivative (PID) require a mathematical model representing the system under control [5]. This can be a major limiting factor for systems with unknown varying dynamics such as inertia variations, components and magnetic saturation, parameter drifts and noisy environments. For most of the basic electric drive applications, these unknown conditions in addition to system nonlinearities can be ignored. High accuracy is not usually imperative. However, for high performance drive applications, disregarding these unknowns may lead to unacceptable tracking performance. Thus, the need for other types of controllers that can account for non linearities requires adaptable conditions in real time. Other methods are now being employed, such as the hybrid fuzzy logic controller, in order to achieve a desired performance level for a high performance motor drive. These controllers, as currently demonstrated by a number of experimenters, show encouraging results [2]-[4]-[10]. In order to get control schemes that would be less sensitive to parameter variations than traditional linear PI controllers, we consider the hybrid controller structure shown in Fig. 1.

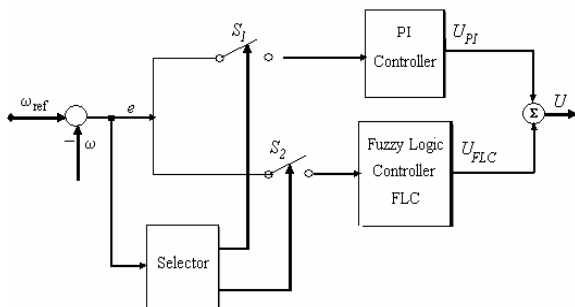

Fig. 1 Structure of hybrid controller

The objective of the hybrid controller is to utilize the best attributes of the PI-type and fuzzy controllers to provide a controller which will produce better response than either the PI or the fuzzy logic controller. The switching between the two controllers needs a reliable basis for determining which controller would be more effective. Both controllers yield good responses to steady-state or slowly changing conditions. To take advantage of the fast response of the PI-type controller, one needs to keep the system responding under the PI controller for a majority of the time, and use the fuzzy controller only the system behaviour is oscillatory or tend to overshoot. As can be seen, it is a controller that contains a PD-type fuzzy and a linear PI control algorithm. It has a single input error signal e(k), which internally yields another fuzzy controller input, change error signal Δe(k). This controller is meant as a multimode controller, which has tree modes of operation dictated by the mode of operation selector (Fig. 1).

IV. FUZZY LOGIC CONTROLLER

Fuzzy logic control design methodologies are justified because imprecision of the mathematical model used previously. Rule-based controllers try accounting the human’s knowledge about how to control a system without requiring a mathematical model [10]-[13]. The main preference of the fuzzy logic is that is easy to implement control that it has the ability of generalisation. The approach of the basic structure of the fuzzy logic controller system is illustrated in Fig. 2.

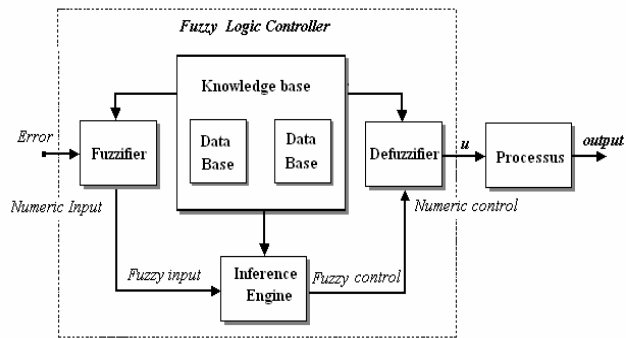

Fig. 2 Structure of Fuzzy Logic Controller

Input and output are non-fuzzy values and the basic configuration of the FLC is featured in Fig. 3.

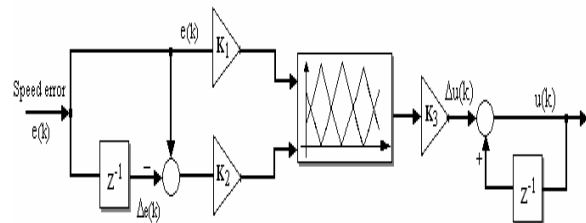

Fig. 3 Block diagram of fuzzy control system

In the system presented in this study, Mamdani type of fuzzy logic is used for speed controller [10]. The command signals to the speed controller are the error ‘e(k)’ and change rate of error ‘Δe(k)’. Speed error e(k) is calculate with comparison between reference speed command ω\_ref

and speed signal feedback  $\omega$ . Speed error and speed error changing are fuzzy controller inputs, so must speed error changing  $\Delta e$  is be calculated. Input variables require be normalized which range of membership functions specify them. The output of the fuzzy controller  $u(k)$  is given by:

$$u(k) = F_f(e(k) - \Delta e(k)) \quad (2)$$

Where  $F_f$  is a non linear function determined by fuzzy parameters,  $e(k)$ ,  $\Delta e(k)$  are the error and change-of-error respectively. A type of those controllers is fuzzy PI controller whose input is the error  $e(k)$ .

$$e(k) = \omega_r^*(k) - \omega_r(k) \quad (3)$$

where  $\omega_r^*(k)$  is the reference model and  $\omega_r(k)$  is the process output at time  $k$ . The fuzzy logic controller was used to produce and adaptive control so that the motor speed  $\omega_r(k)$  can accurately track the reference command  $\omega_r^*(k)$ . In Fig. 2, normalisation factors have be shown with  $K_1$  and  $K_2$ . Fuzzy logic controller is based on three well known blocs: Fuzzyfication bloc, block of rule bases and defuzzyfication block, whose function is following briefly explained. The fuzzyfication stage transforms crisp values from a process into fuzzy sets. The second stage is the fuzzy rule bases which expresses relations between the input fuzzy sets of linguistic description rules  $A$ ,  $B$  and the output fuzzy set  $C$  in the form of " IF  $A$  and  $B$  – THEN ", and the defuzzyfication stage transforms the fuzzy sets in the output space into crisp control signals. As fuzzy system, we are considering a fuzzy PD controller. The control algorithm is represented by fuzzy rules [3]-[7]-[10]. The first step in designing the fuzzy controller is to generate the fuzzy rules based on the knowledge of the expert. According to the expert, three situations can be distinguished for the motor speed, namely, above, around and below the desired reference speed. The linguistic representation of the motor speed with respect to a given desired reference speed can be easily translated into a linguistic characterisation of the system error. By defining the system error between the measured speed and the desired speed, the propositions, higher, around and beneath the desired reference speeds are otherwise expressed as Positive, Zero and Negative errors. Furthermore, for given system state variables, the expert can express how he would act if he was controlling the system. For example, a typical rule reads as follows:

**IF** speed error is Positive Small (**PS**),  
**AND** rate of change in speed error is negative small (**NS**)  
**THEN** change in motor voltage  
 (Output of fuzzy controller is Zero (**Z**))

The second step consists of modifying the rule-base in order to satisfy the requirements induced by the proposed strategy. The fuzzy controller has to produce a null action when the system has a normal behaviour. In other words, a dead zone has to be generated by the fuzzy controller, thus defining the zone where PI control is used. Furthermore, a null fuzzy action is desired when the system is not oscillatory and the overshoot very reduced. Nonetheless, the system is anomalous when it has oscillatory or tends to overshoot. Consequently, anomalous behaviour is defined as speed errors being zero and its change being not zero. Thus, the following set of rules:

Vol.1, No.2, 2007  
 If speed error is Zero (**Z**),  
**AND** rate of change in speed error is another value,  
**THEN** control is null.

For the proposed fuzzy controller, the universe of discourse is first partitioned into the five linguistic variables NB, NS, ZE, PS, PB, triangular membership functions are chosen to represent the linguistic variables and fuzzy singletons for the outputs are used. The fuzzy rules that produce this control action is reported in Table I.

TABLE I  
 SET OF GENERATED FUZZY RULES FOR PROPOSING SYSTEM

Error	NB	NS	ZE	PS	PB
Delta Error	NB	NS	ZE	PS	PB
NB	NB	NS	ZE	PS	PB
NS	ZE	NS	ZE	PS	ZE
ZE	PB	PB	ZE	PS	NB
PS	ZE	PS	PB	NS	NB
PB	PB	PS	NS	NS	NB

This implies an inference engine based on 5 implications rules for each of the speed error and its variation, thus a total 25 combinations take place. One can see on Table I, the rules sets of the fuzzy controller. Fig. 3 shows an example of Mamdani's fuzzy inference [10], assuming that applicable fuzzy rules are:

**Rule\_1:** IF  $e(k)$  is **PS** AND  $\Delta e(k)$  is **PM** , THEN  $u(k)$  is **PS**;  
**Rule\_2:** IF  $e(k)$  is **PM** AND  $\Delta e(k)$  is **PS** , THEN  $u(k)$  is **PM**

where  $e(k)$ ,  $\Delta e(k)$ ,  $u$  are the speed error, the change rate of speed error and the control action, respectively. The inference law is given as:

$$\mu_F(u) = \text{Max}_{(i,j,k)} \in I \text{ Min}(\mu_{L_{ei}}(e), \mu_{L_{\Delta e}}(\Delta e)), \mu_{L_{uk}}(u)) \quad (4)$$

$\mu_F(u)$  design the fuzzy control action.

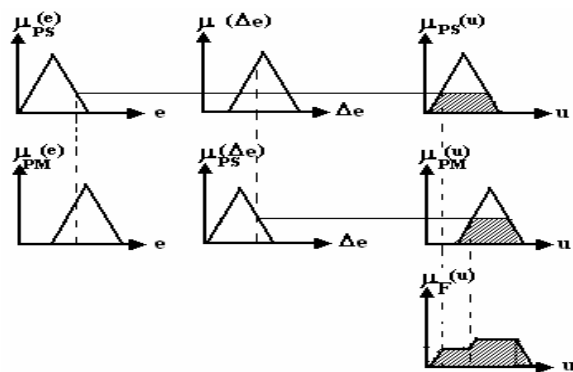

Fig. 3 Mamdani's fuzzy inference

The controller treats each measurement as a fuzzy singleton and fuzzifies it using the fuzzy sets shown in Fig. 4 where **NB**: Negative Big, **PB**: Positive Big, **NS**: Negative Small, **PS**: Positive Small and **ZE**: Zero Equal.

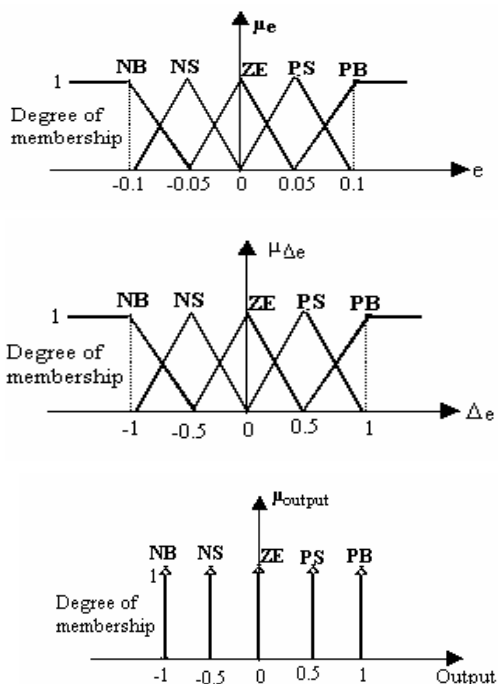

Fig. 4 Fuzzy sets and its memberships functions

Triangular shapes were chosen as the membership functions due to the linear equation in evaluation of membership functions and the output of the fuzzy controller is illustrated in Fig. 3.

V. CONFIGURATION OF THE PROPOSED CONTROL SYSTEM

Block diagram of implemented drive using fuzzy controller consists of the components illustrated in Fig. 5. The software environment used of these simulation experiments is Matlab with Simulink Toolboxes.

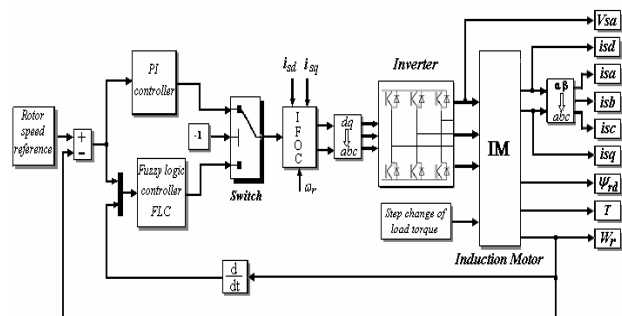

Fig. 5 Block diagram of implemented drive

The objective of the hybrid controller is to utilize best attributes of the PI-type and fuzzy controllers to provide a controller which will produce better response than either the PI or the fuzzy controller. The switching between the two controllers needs a reliable basis for determining which controller would be more effective. The answer could be derived by looking at the advantages of each controller. Both controllers yield good responses to steady state or slowly changing conditions. Careful choice of the method of combining the controllers may result in a highly adequate yet non-oscillatory response. To take advantage of the rapid response of the PI-type controller, one needs to keep the

VI. SIMULATION RESULTS

To demonstrate the proposed hybrid fuzzy control scheme success, it has been tested by simulation, in order to evaluate the performances under a variety of operating conditions. The numerical values for the tested induction motor are summarized in Table II. The controller algorithm is housed inside the personal computer with Pentium-4 microprocessor and all numerical values of the simulation model are obtained either by measurements. The software environment used of these simulation experiments is Matlab-software with Simulink Toolboxes. For all simulations performed in this paper, the best gain, found experimentally to be  $k_p=0.56$  and  $k_i = 10.04$ .

TABLE II  
 RATING OF TESTED INDUCTION MOTOR

Rated values	Power	4	kW
	Frequency	50	Hz
	Voltage Δ/Y	220/380	V
	Current Δ/Y	15/8,6	A
	Motor Speed	1440	rpm
	pole pair (p)	2	
Rated parameters	$R_s$	1,2	$\Omega$
	$R_r$	1,8	$\Omega$
	$L_s$	0,1554	H
	$L_r$	0,1564	H
	M	0,15	H
Constant	J	0,013	kg,m <sup>2</sup>

After designing the best stand alone PI and fuzzy controllers, all effectiveness of combining the two controllers to produce a hybrid design is demonstrated. Simulation results are given for motor speed tracking with the desired speed changing from the level to another (square-wave reference track with amplitude 150 rad/s). Figs. 6 and 7 show the speed trajectory when the desired speed changes from one value to another, using the PI controller and the Fuzzy controller, respectively. The measured speed is superimposed on the specified desired speed in order to compare tracking accuracy. Clearly, the fuzzy controller reduces both the overshoot and extent of oscillations under the same operating conditions. As shown in Fig. 6, the PI controller exhibits some overshoot or oscillations as the measured speed approaches the desired speed. To demonstrate the robustness of the proposed controller a different type of trajectory was considered in this test. Figs. 8, 9, 10, 11 show the results, in the case of a combined square-sinusoidal and square-triangular references speed track, for which  $\omega_r^*(k)$  has an amplitude of 150 (rad/s) and wavelength of 1.0 (sec). High tracking accuracy is observed at all speed. One can see from these figures that the results using fuzzy controller, were very successful.

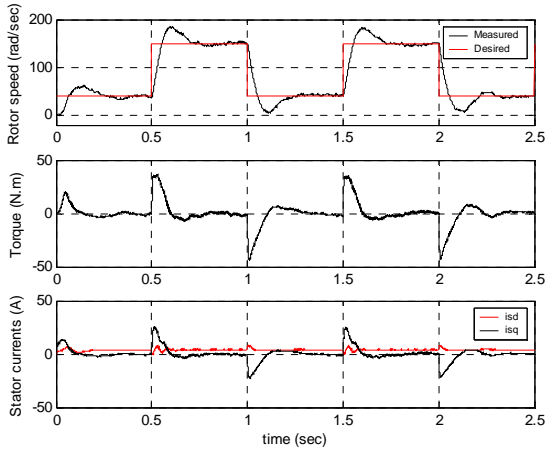

Fig. 6 Results of speed control system using PI Controller

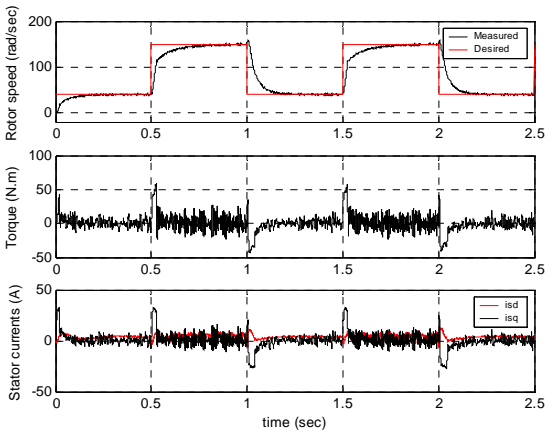

Fig. 7 Results of speed control using fuzzy controller with stochastic load changes

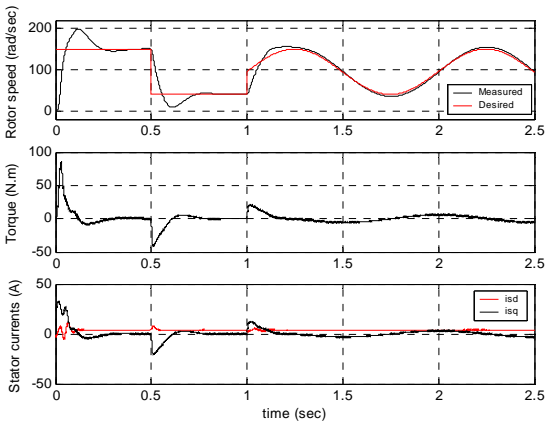

Fig. 8 Results of speed control of a square-sinusoidal reference track using PI controller

To illustrate the effectiveness of the switching strategy further, the hybrid controller was applied to control the motor under variable load torque. It is observed from Figs.12,13,14, that the hybrid controller closely tracks the motor speeds, even under changing conditions. Rejection of external disturbances is also achieved. Compared with the motor speed response with variable load, it can be seen that the undesirable oscillatory response is clearly evident.

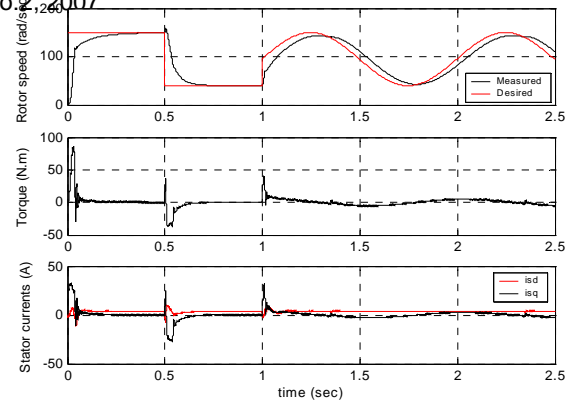

Fig. 9 Results of speed control of a square-sinusoidal reference track using fuzzy controller

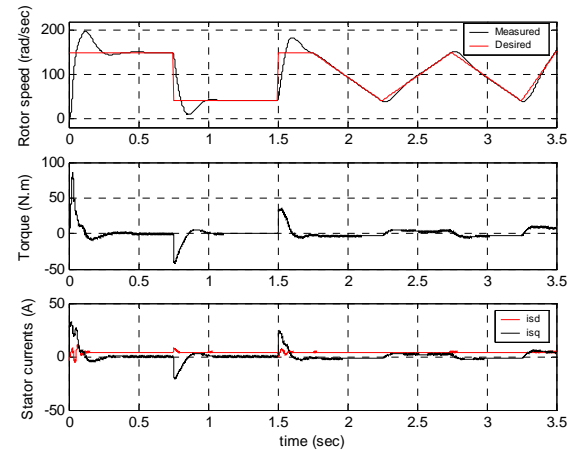

Fig. 10 Results of speed control of a square-triangular reference track using PI controller

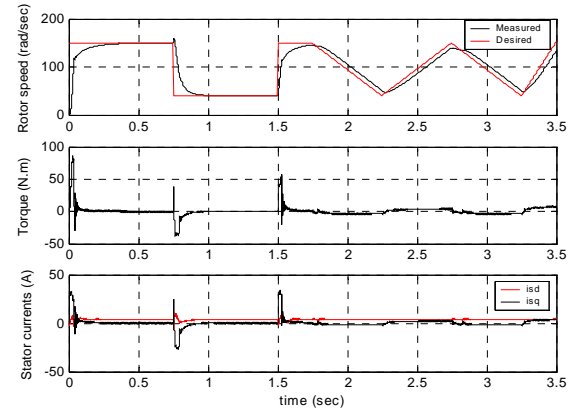

Fig. 11 Results of speed control of a square-triangular reference track using fuzzy controller

All test results show that the proposed hybrid fuzzy control strategy is very effective in tracking the selected tracks at all time, while the system transients are effectively reduced. The results presented in Figs. 10, 11, 12, 13, 14 show that the proposed control system works correctly. The plots of these figures show the performance as the proposed scheme of hybrid-fuzzy controller for variety of step changes in the desired set point. It can be observed that, the application of external force of 10 (N.m) to induction motor, the control and set-point following are satisfactory.

In order to examine the robustness of the proposed control scheme, we assume that the parameters of rotor resistance  $R_r$  and load inertia  $J$  have been perturbed from their nominal values.

Vol.1, No.2, 2007  
 conventional controllers, such as the Proportional Integral PI-type. The controller envisaged is capable of maintaining a high tracking accuracy even in the presence of sudden disturbances such as load of electric transients.

## VII. CONCLUSION

We have proposed a simple, yet effective, switching control strategy for tracking application of an induction motor drive. The proposed control system was analysed and implemented and its effectiveness in tracking application was verified. From the above results it is clear that the proposed controller despite of its simple structure has all of the futures of a high precision speed controller for operating in the whole of speed range and for any loading and environmental conditions. The proposed control scheme had a good speed response regardless of parameter variation or external force. The results are promising and further studied on similar schemes will be carried out. Satisfactory performance was observed for most reference tracks.

## REFERENCES

- [1] Y. Tang and L. Xu. Fuzzy logic application for intelligent control of a variable speed drive. *IEEE Trans. Energy Conversion*, Vol. 9, pp. 679-685, Dec. 1994.
- [2] G.C.D. Souza, B.K. Bose and J.G. Cleland. Fuzzy logic based on-line efficiency optimization control of an indirect vector controlled induction motor drive, *IEEE-IECOM Conf. Maui, HI*, pp.1168-1174, November 1993.
- [3] C.M. Liaw, Y.S. Kung and C.M. Wu. Design and implementation of a high-performance field-oriented induction motor drive. *IEEE Trans. Ind. Electron.*, vol.38, 4, pp. 275-282,1991.
- [4] A. Rubaai and M. D. Kankam, Experimental verification of hybrid fuzzy control strategy for high performance brushless DC drive system, *IEEE Trans. On industry applications* Vol.17, n°2, March-April 2001, pp. 503-512.
- [5] H.C. Tseng and V.H. Hwang. Servo-controller tuning with fuzzy logic. *IEEE Trans. Contr. Syst. Technol.* Vol. 1, pp. 262-29, Dec.1993.
- [6] C.C. Lee. Fuzzy logic in control systems: Fuzzy logic Controller I & II. *IEEE Trans. On Systems, Man and Cybernetic.* Vol. 20, pp.404-418, March-April 1990.
- [7] S. A. Mir, D.S. Zinger and M.E. Elbuluk. Fuzzy controller for inverter fed induction machines. *IEEE Trans. Ind. Applic.* Vol. 30, pp. 78-84, Jan-Feb. 1994.
- [8] Y. Edward, Y. Ho and C. Paresh. Control dynamics of speed drive systems using sliding mode controllers with integral compensation. *IEEE Trans. On Industry Applications*, Vol., 27, No.5, Sept-Oct. 1991.
- [9] Jie Zhang and T. H. Burton. New approach to field orientation control of CSI induction motor drive. *IEE Proceedings*, Vol.135, Pt. B. No.1; January 1988.
- [10] E.H. Mamdani and S. Assilian. An experiment in linguistic synthesis with a fuzzy logic controller. *International Journal of Machine Studies*. Vol. VII, pp.1-13, 1975.
- [11] G.C.D. Souza and B.K. Bose. A fuzzy set theory based control of a phase controlled converter DC machine drive, *IEE-IAS Annu. Meeting Conf. Rec., Dearborn, MI*, pp.854-861, October 1991.
- [12] C. Won, S. Kim and B.K. Bose. Robust position control of induction motor using fuzzy logic control. In *Con. Rec. IEEE-IAS Annu. Meeting, Conf. Rec.*, pp.472-451, Oct. 1992.
- [13] L. Zadeh. Outline of a new approach to the analysis of complex systems and decision processes. *IEEE Trans. Syst., Man, Cyben.*, Vol.3.pp.28-44, Jan. 1973.

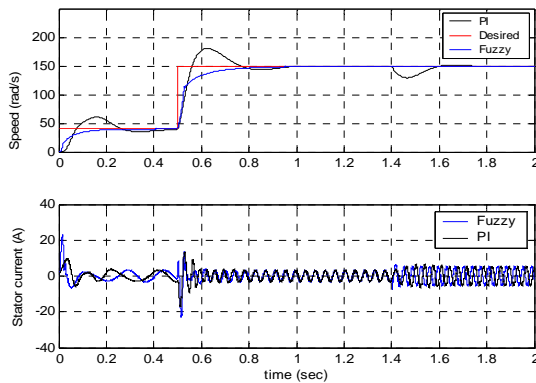

Fig. 12 Results of speed evolution after reference track step and inertia load changes

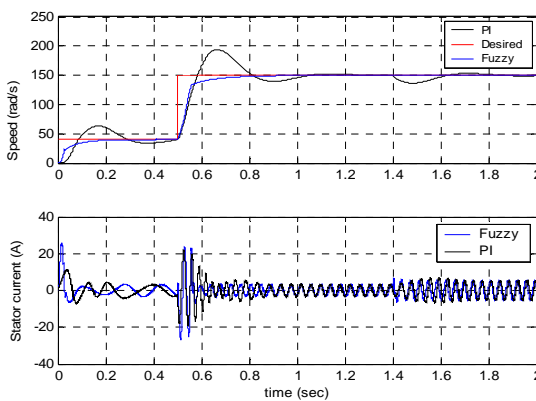

Fig. 13 Results of speed control after reference track and inertia changes, under load

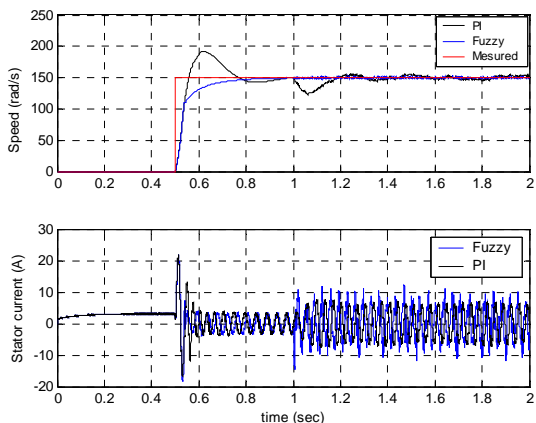

Fig. 14 Speed step response under load and rotor resistance changes

The parameters of stator resistance, inductances and viscous friction  $f$  maintain their nominal values. It is evident that the speed response of the proposed control scheme is not significantly affected by these variations. One can see from these all figures the results were very successful and the obtained results confirm the validity of the proposed control scheme. These figures reveal that the proposed controller based on the hybrid fuzzy scheme was superior to



**Mokhtar Zerikat** (M'05) received the V.B.S. degree in electrical engineering and the M.S. and Ph.D degrees in electronics from the University of Sciences and Technology of Oran, Algeria, in 1982, 1992, and 2002, respectively. Following graduation, he joined the university as a lecturer. He is currently a professor in the department of electrotechnics engineering. He is engaged in research and in education in the area of

electrotechnics. Actually he is associate Professor at Electrical Engineering Institute (ENSET) of Oran- Algeria. His current research includes electrical machines, High-performance motor drives, modelling and adaptive control systems, image processing and development intelligent applications. He is actively involved in many projects with industry while engaged in teaching, research and consulting in the area of artificial intelligence. Actually, he is associate Professor at the department of electrical engineering (ENSET) of Oran in Algeria. He has authored more than 45 technical papers published in international journals and conferences proceedings. He authored a book on automatic Control, which was recently published and regularly gives tutorials and industrial courses on these subjects.

Dr. Zerikat is a chairman of the institute of electrical and electronic engineers in the Algeria state. He is regularly reviews papers for several journals in his area. He is an active member of the industrial COST Education Committee.



**Sofiane Chekroun** was born in Oran, Algeria, in 1982. He received his B.S and M.S degrees in Electrical Engineering from the University of Sciences and Technology of Oran, Algeria. Following graduation, he joined the Institute of Electrical Engineering of ENSET Oran, Algeria, as a research h associate. His research interests include Electrical machines and development of

intelligent applications (fuzzy logic and neural networks) and the practical developments of high performance electrical motor derives and their related knowledge control schemes.