

# Design and Development of iLON Smart Server Based Remote Monitoring System for Induction Motors

G. S. Ayyappan, M. Raja Raghavan, R. Poonthalir, Kota Srinivas, B. Ramesh Babu

**Abstract**—Electrical energy demand in the World and particularly in India, is increasing drastically more than its production over a period of time. In order to reduce the demand-supply gap, conserving energy becomes mandatory. Induction motors are the main driving force in the industries and contributes to about half of the total plant energy consumption. By effective monitoring and control of induction motors, huge electricity can be saved. This paper deals about the design and development of such a system, which employs iLON Smart Server and motor performance monitoring nodes. These nodes will monitor the performance of induction motors on-line, on-site and in-situ in the industries. The node monitors the performance of motors by simply measuring the electrical power input and motor shaft speed; coupled to genetic algorithm to estimate motor efficiency. The nodes are connected to the iLON Server through RS485 network. The web server collects the motor performance data from nodes, displays online, logs periodically, analyzes, alerts, and generates reports. The system could be effectively used to operate the motor around its Best Operating Point (BOP) as well as to perform the Life Cycle Assessment of Induction motors used in the industries in continuous operation.

**Keywords**—Best operating point, iLON smart server, motor asset management, LONWORKS, Modbus RTU, motor performance.

## I. INTRODUCTION

INDIA is a highly populated country; larger the population, larger the demand for the product and other utilities. The global electricity demand by application wise [1] is shown in Fig. 1. The primary energy consumption in India is the third biggest after China and USA with 5.3% global share in 2015 [1]. One of the major features of the developing country is industrialization which leads to increase in energy consumption on a larger scale. India is expected to become the second largest contributor with respect to increased global energy demand by 2035 [4]. This accounts for 18% of the increase in global energy consumption [4].

Induction motors are considered to be the largest users of

This work was funded by Instrument Development Program - Department of Science & Technology (IDP-DST), New Delhi, India under Grant IDP/IND/2010/17 (Capital & General) dated 14-09-2012.

Ayyappan G.S. and Srinivas Kota are with Council of Scientific & Industrial Research-Central Scientific Instruments Organisation (CSIR-CSIO), Chennai Centre, CSIR Madras Complex, Taramani, Chennai 600113, India (e-mail: ayyappangs@csircmc.res.in, sriniwaskota@gmail.com).

Raja Raghavan M. and Poonthalir R. are with CSIR-CSIO Chennai Centre, Taramani, Chennai 600113, India (e-mail: mrajaraghavan@gmail.com, poonthalir09@gmail.com).

Ramesh Babu B. is with CSIR-Central Electro Chemical Research Institute (CECRI), Karaikudi 630005, India (e-mail: brbabu2011@gmail.com).

electrical energy among all motors. They are used in a wide range of commercial and industrial applications, including fans, compressors, pumps, conveyors, winders, mills, transports, elevators, home appliances, and office equipment. The energy consumption of motors is around 50% to 60% of the total plant consumption. As per the statistical report [2], the sector-wise energy saving potential through motors in India is shown in Table I.

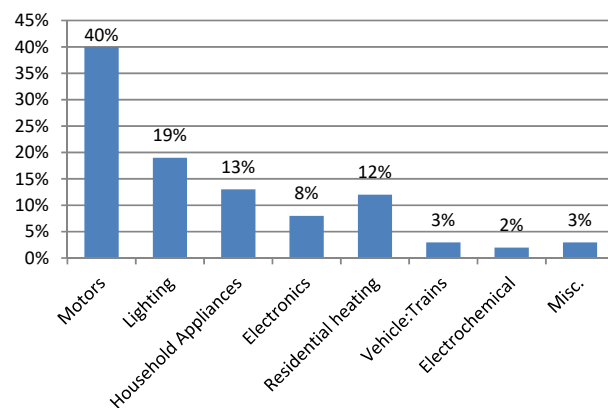

Fig. 1 Global Electricity demand by application [1]

TABLE I  
SECTOR WISE ENERGY SAVING POTENTIAL ON MOTORS IN INDIA [13]

Sector	Energy Handled by Motors (%)	Conservation Potential (%)
Industrial Sector	70-75%	Up to 25%
Agriculture Sector	20-25%	Up to 30%
Domestic Sector	2-3%	Up to 20%
Commercial Sector	4-5%	Up to 30%

In order to conserve energy, it is necessary to operate the motors very efficiently. Measuring the operating efficiency of motor on-line helps in identifying the motors for

- Refurbishment/Replacement of old motors with new motors through Motor Asset Management (MAM) [3],
- Checking the efficiency of the motor after rewinding [4],
- Operating the motor around its BOP wherever it is possible.

Wachter et al. [3] discussed the various effects of running a motor at low efficiency. A low energy efficiency motor will dissipate its losses in the form of heat. As a result, there will be a significant increase in the energy cost. Also, the heat generated will affect the motor condition, thereby reducing its

energy efficiency even further and increasing the risk of unplanned failures [3]. By keeping this in mind, CSIO has developed Universal Motor Performance Analyzer (UMPA) [5], [6], which is going to play a vital role in industries for monitoring the motor performance as well as conserving energy through induction motors. Fig. 2 shows the view of the developed UMPA unit. The developed UMPA system does not require the removal of motor from the load and conducting no-load and blocked rotor tests, which are cumbersome at site. The system measures the electrical input parameters and motor shaft speed on-line, and the stator resistance off-line. Measured data are coupled with few nameplate details of the motor; the system estimates the motor equivalent circuit parameters using Genetic Algorithm (GA) [5]-[8]. The estimated motor equivalent circuit parameters are stored in the system SD card. The motor losses are computed from the equivalent circuit parameters, motor input parameters, and motor shaft speed. The motor operating efficiency, mechanical power output, and torque are then calculated. The developed system is best suitable for conducting motor performance study on squirrel cage, slip ring induction motors both with and without VFD.



Fig. 2 View of the developed Motor Performance Analyzer (UMPA)

UMPA could be suitable for conducting on-site energy audits of existing motors which provides scientific data to replace or refurbish the existing motor, aiming to conserve energy. The advantages of the developed UMPA system over the existing methods are listed below:

- Monitoring the motor operating efficiency on-line, on-site and in-situ at any load conditions.
- No need to disconnect the motor from the load.
- No need to measure the output power or torque.
- No need to conduct no-load or blocked-rotor test.
- No more assumptions.

This paper deals with the design and development of Web Server based remote monitoring system for induction motors in continuous operations. The system uses embedded web server, number of Motor Performance Monitoring (MPM) nodes connected to a network and dedicated software for remote monitoring. MPM node is similar to MPA in all aspects except that MPA is a portable unit, whereas MPM node is a fixed unit. The MPM node is permanently installed near the motor using fixed panel Current Transformers (CTs) and speed sensor. The view of the developed MPM node is

shown in Fig. 3. The node monitors the motor performance data and communicates to the Embedded Web Server using MODBUS RTU communication protocol. Multiple MPM nodes could be coupled to the industrial RS485 network for continuous monitoring and targeting in the plant.



Fig. 3 View of the developed MPM Node

Each MPM node is built with RS485 connectivity and assigned with a unique ID. The nodes are connected to the RS485 network using twisted-pair wires for reliability. Modbus RTU slave side communication protocol is embedded in the nodes. The iLON Web server collects all the information pertaining to the motor performance and displays them online using dynamic web pages. Logging of motor performance data into database periodically at a predefined interval, analyzing the data, alarm & annunciation in the event of abnormalities via SMS and email alert, scheduled report generation & transmitting reports over emails, and configuration are implemented in the developed system. The system could be effectively used to operate the motor around its BOP as well as to perform the Asset Management on motors used in the industries in continuous operation.

The developed system will play a major role in MAM in the industries in continuous operations. The advantages of MAM are improved energy efficiency, reduced maintenance costs through predictive & precision maintenance, reduced risk of unplanned outages through repair or replace decision-making process, minimized Total Cost of Ownership (TCO) for the motor etc. [3]

## II. MATERIALS AND METHODS

### A. Hardware Description

Fig. 4 shows the system block diagram of the web-enabled & networked remote monitoring system for induction motors, which is used for monitoring multiple motor performances in the industries. The components of the system are MPM nodes & an embedded web server. The MPM nodes are designed & configured in the network mode for multi-motor performance analysis using the RS485 network. The nodes are networked

using twisted-pair wire in multi-drop mode, which can be connected to an Industrial Embedded Server. This enables the system to be viewed from the PCs connected in the intranet (LAN) or internet (WAN). User friendly web pages are incorporated in the system which facilitates the user to log on to the system, display the motor performance in multiple tabs, on-line trend graph of the selected parameters, configuring the

system, logging the data into database at a predefined interval, reporting the data with auto-generate features & analyze the motor for its performance. The system can generate auto report, alarm & annunciation in the event of any abnormal conditions in the performance by means of audio and visuals in the system and also by SMS, email services.

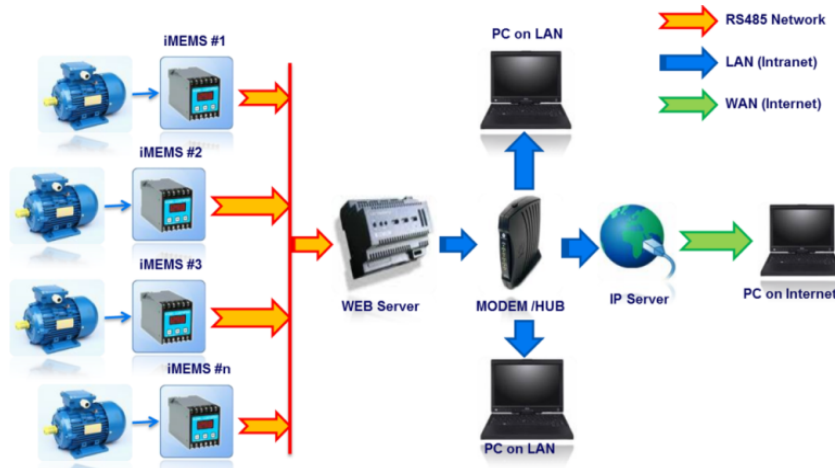

Fig. 4 Block diagram of the developed system

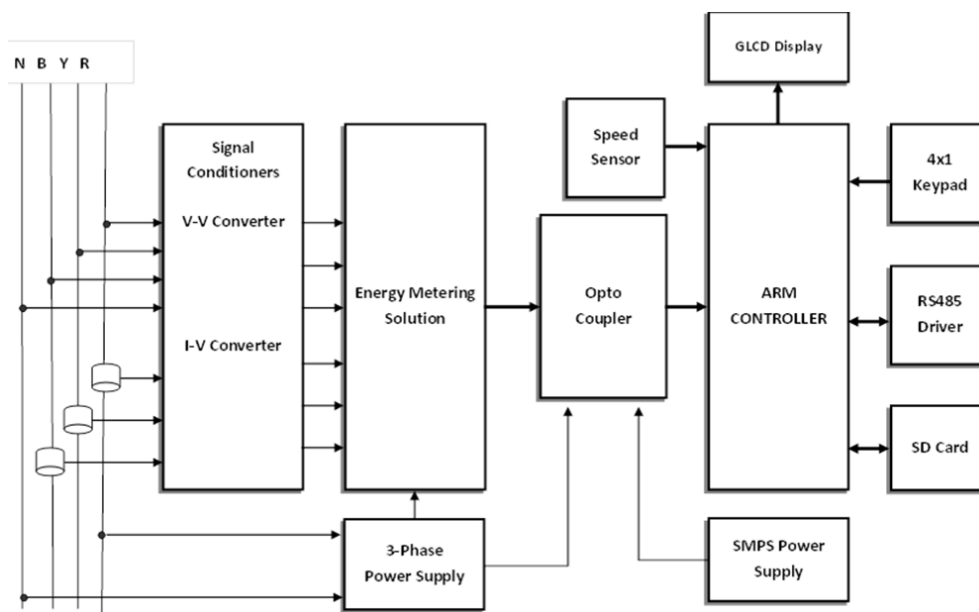

Fig. 5 Functional block diagram of MPM Node

### B. MPM Node

The MPM node is built around the cost-effective 32-bit ARM controller; measurement functions are built around ASIC chip-based energy metering solution and non-contact optical proximity speed sensor. The ARM controller is the best choice for this type of application, where large amount of data are to be handled with high-speed execution for running the powerful algorithm like GA etc. Fig. 5 shows the

functional block diagram of the developed MPM node. Fig. 6 shows the view of developed hardware of MPM node.

The sub-systems of the MPM node are listed below:

- Microcontroller Unit
- Power Measuring Unit
- Speed Measuring Unit
- Display & Keypad Unit
- Communication Unit

- Power Supply Unit

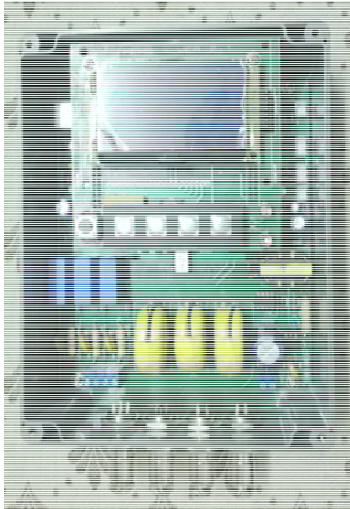

Fig. 6 View of the developed hardware

**Microcontroller Unit:** The developed node is built around the ARM Cortex M4 Microcontroller, which is a low-cost controller suitable to make it a cost-effective solution. Necessary hardware interfacing circuitries like the reset circuitry, clock oscillatory circuitry, etc., are provided in the Microcontroller Unit.

**Power Measuring Unit:** It is used to measure the electrical parameters like the phase-wise voltage, current, power factor, phase-wise power and cumulative powers (kW, kVA, kVAr), cumulative energies (kWh & kVarh), status and frequency of the 3-phase induction motor. This requires an accurate measurement of 3-phase power (kW) with an accuracy of  $\pm 1\%$  or less. Commercially available ASIC energy metering solution is employed along with necessary signal conditioners and protection circuitries.

**Speed Measuring Unit:** In order to find the efficiency of the motor, MPM node requires the measurement of motor shaft speed. Since the measurement of speed is to be carried out in the field and being continuous, a non-contact speed measurement is preferred. The Speed Measuring Unit is built around cost-effective optical proximity speed sensor as shown in Fig. 7 with necessary signal conditioning circuits.



Fig. 7 View of the Non-contact Optical Proximity Speed Sensor

**Display & Keypad Unit:** The Human Machine Interface (HMI) is provided by using an alphanumeric LCD display or

graphical LCD and a 4x1 membrane keypad. The user can feed some of the configuration parameters and select different display parameter screen using the keypad.

**Communication Unit:** The system is facilitated with the RS485 communication interface, which enables the MPM nodes to be remotely monitored from the embedded web server.

**Power Supply Unit:** Necessary power supplies at rated conditions are designed with protection features.

### C. Embedded Web Server

The system uses iLON Smart Server as shown in Fig. 8, a product of M/s Echelon Corporation, as embedded web server [9]. The Smart Server is a versatile smart energy manager that connects control devices to IP-based applications such as enterprise energy management, demand response programs, street light management systems, and high-value remote asset management programs.



Fig. 8 View of the iLON Smart Server

The key features of iLON Smart Server used in the system include built-in drivers for industry standard protocols like LonWorks® free topology, power line, and IP-852 and built-in Web-user and Web-services interfaces for scheduling, alarming, data logging, and meter reading. It can handle up to 300 devices as a stand-alone network manager or connects OpenLNS and LNS®-managed networks using seamless integration with the Echelon OpenLNS Server and LNS Server. It is also capable of local monitoring and control as well as integration with enterprise applications for energy management of commercial buildings, offices, street lights, solar arrays, etc. It allows customization for applications such as energy optimization, data analysis, and room and lighting control. It supports development of customized Web pages with the included i.LON® Vision tool.

The iLON Smart Server used in the system has the following connectivity:

- Ethernet Port: 10/100BaseT, auto-selecting, auto-polarity
- Serial Ports: One isolated RS485 port; One EIA232 port
- Modem: V.90 internal analog modem (Model 72012R-440) (Optional)
- Supports other External Modems: Cinterion MC75, Cinterion MC63i, ETM9300 1 3G, Janus Terminus GSM864Q, Multitech MTCBA-G-F1, Siemens 35 to 45 Series, Siemens MC55 3G, Siemens MC75 EDGE
- Console Port: EIA-232
- Digital Inputs: Two optically isolated dry contact inputs,

30V AC/DC

- Relay Outputs: 2 SPST Relays
- Impulse Meter Inputs

The MODBUS slave side protocol is implemented in the MPM nodes. Multiple MPM nodes will be connected to the iLON Smart Server through RS485 network. The iLON server is configured for data acquisition, browsing & data logging from the MPM nodes. The iLON server can provide email service, SMS service and also has limited built-in control capabilities. Necessary software modules are developed using Microsoft .Net Framework using C# under Visual Studio. The iLON Smart Server can be connected to any available LAN connection and configured.

#### D. Software Description

The software developed for the operation of MPM Node is called as the firmware software or embedded software. The program is written in a high level language like C and using the KEIL MDK-ARM Vision 4.0 as an Integrated Development Environment (IDE). The final output of the program, 'axf' file is then stored in the Flash Memory of the MPM Node. The software modules required for the functioning of MPM Node are developed and implemented. Fig. 9 shows the overall functions used in MPM node as

flowchart. Some of the modules used in this application are listed below:

- Initialization Algorithms
- Calibration Algorithm
- Configuration of MPM Node
- Power & Speed Measurement Algorithm
- Motor Parameter Estimation Algorithm
- Performance Computation Algorithm
- Display Parameters
- Modbus Communication

#### E. MODBUS Communication Protocol

MODBUS RTU Slave side communication protocol is implemented on MPM node. It is a point to point, open serial communication protocol. This protocol is employed in the developed system, which uses two-wired twisted-pair RS485 communication network. It is used to develop one-Master, Multi-Slave Server-Client communication between intelligent devices. In Modbus RTU, RS485 can be used as physical layer based on the specification of the physical layer. RS485 uses a half-duplex mode in which transmission and receiving process are carried one after another [10]. RS232, RS422, and RS485 can also differentiate on the basis of baud rate and data transport rate.

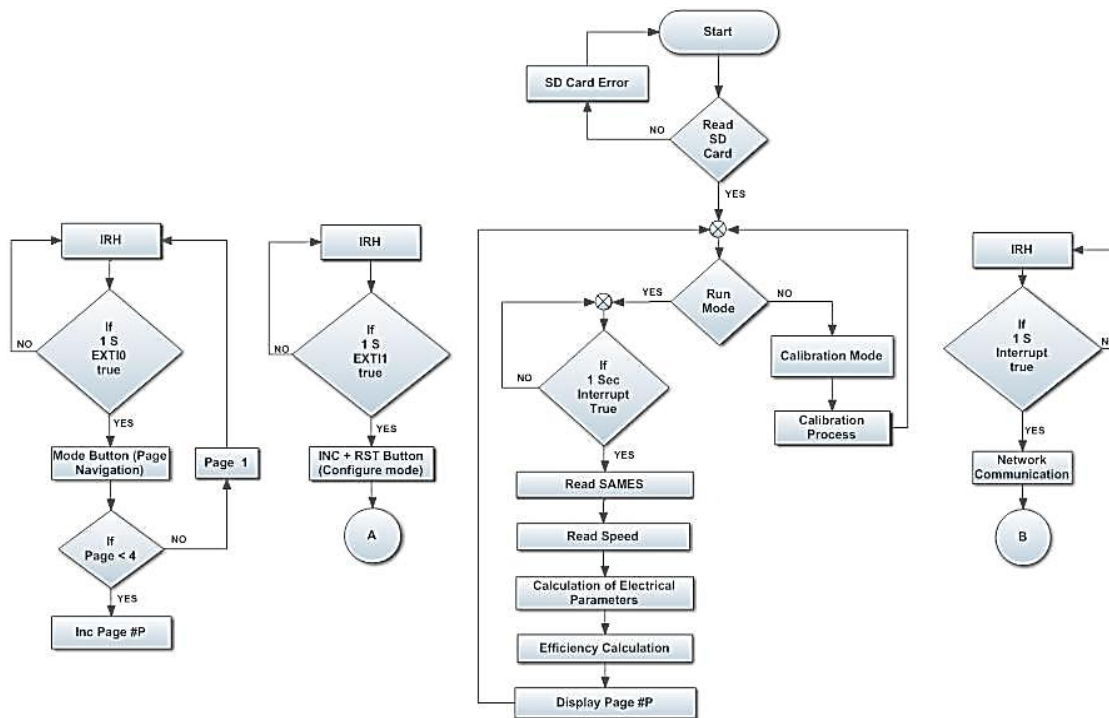

Fig. 9 Flowchart - Overall Functions of MPM Node

In MODBUS RTU, physical layer is responsible for slave address, start bit, stop bit, data, Cyclic Redundancy Check (CRC) code, time out and framing error detection. Data link layer is responsible for function code recognition or rejection and busy or re-pool data. In Modbus RTU, the master device sends a query to slave devices and slave devices receive the

query. A particular slave device with the given ID will send a response to master according to the specified function code. Fig. 10 shows the frame format of Modbus RTU.

Each transaction in MODBUS RTU uses packets and each packet consists of many fields which are shown in Fig. 11 and described below:

- Slave ID: Slave ID is one-byte address field. At maximum, we can connect 256 devices to MODBUS network. Slave ID 0 is used for broadcasting or as a master. Slave IDs 1 to 247 is used for slave devices and IDs 248 to 255 is used for gateways.
- Function Code: The function code is 1-byte address field. The function code in query tells the slave device what kind of action to be executed. Some of the function codes which are frequently used in this system are 08, 04 and 03.
- Data: The data field is a single byte address field. Data field consists of one start bit, 8-bit data and one or two stop bits. The data field contains data of field devices which are united into a network.
- Error Code: Two types of error codes are available in MODBUS protocol. CRC is used in MODBUS RTU protocol whereas Longitudinal Redundancy Check (LRC)

is used in MODBUS ASCII protocol for error check-in data transmission over the physical layer.

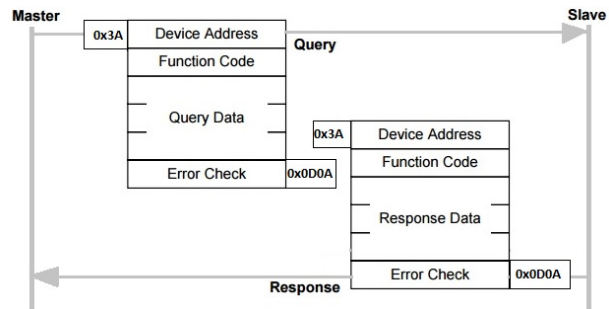

Fig. 10 Frame Format in Modbus RTU protocol

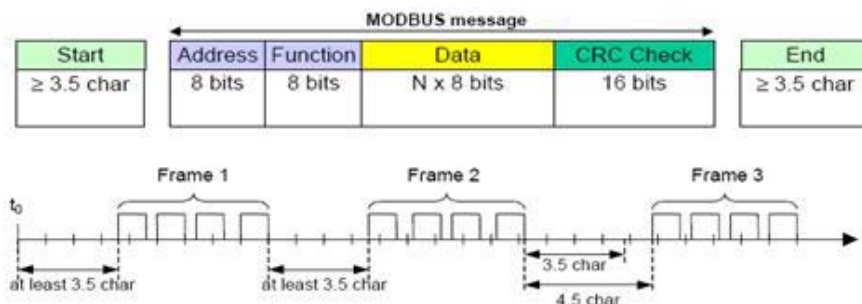

Fig. 11 Message Packet in Modbus RTU Modbus Message

#### F. Web Server Software

Necessary software modules are developed and incorporated in the iLON Smart Web server. Two types of software modules are developed. They are named as Win App and Web App. The Win App software is developed using C# platform and back-end using SQL server. The Win App consists of the following software modules:

- Configuration Module with password authentication
- MODBUS Master Communication Protocol (built-in)
- Data Acquisition from the MPM Nodes
- Storing the data in the online database which gets updated at one-second interval with time-stamp
- Logging of nodes' data in the offline database which gets appended periodically at a predefined interval with time-stamp

The Web App software is developed using C# & .Net platform and back-end using SQL server. The Web App software consists of the following modules:

- Registered user Login with username and password protection
- Online display of data by accessing the online database with status of node
- Report generation
- Offline data analysis like peaking, averaging, cumulative energy details etc.
- Online and offline historical trending, bar chart, pie chart

etc.

- Alarm and annunciation in the event of abnormalities.
- The motor performance details like motor operating efficiency along with electrical power input, mechanical power output, speed, torque, and motor losses are displayed on the dynamic web pages. The information collected is stored in the database periodically at a predefined interval. The software developed has three level of authentications such as administrative, supervisory and operator level.

### III. RESULTS AND DISCUSSION

#### A. Testing of MPM Node with Standards

The MPM node is designed, developed, calibrated, and tested for its functionality in the lab using simulated data. The developed unit is then evaluated to the IEEE112-B Standard [11] and IEC-60034-2-1 Standard [12]. In order to evaluate the developed MPM node, the Motor Test Centre established in the lab is used, which is shown in Fig. 12. The Motor test bench is used to evaluate the developed MPM node with different motor capacities. The performance is compared for 5 HP and 10 HP motors with the conventional method (IEC 60034-2-1) using the test bench. The MPM Node was evaluated on 10 HP motor installed on the test bed against the standards and found less than  $\pm 1\%$  error on efficiency as shown in Fig. 13.



Fig. 12 View of the Motor Test Centre available at Lab

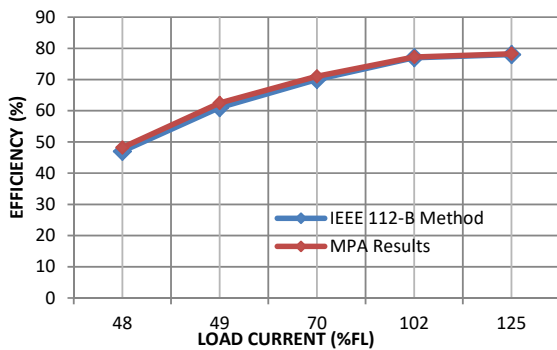

Fig. 13 Comparison of test results of MPM Node against Standards

**B. Installation & Testing of Remote Monitoring System**

The web-enabled and networked remote monitoring system for induction motor is successfully developed, tested and demonstrated at one of the site. The industry uses a compressor system driven by nine numbers of 100 HP 3-phase induction motors and one 15 HP motor for the cooling tower. Ten numbers of MPM nodes are assembled, fabricated, tested and calibrated in the lab. The system is tested for its

functionality and found satisfactory. Fig. 14 shows the view of the developed and tested Networked Remote Monitoring System installed at that site.



Fig. 14 View of the developed system installed in the field

All the ten MPM nodes along with iLON Smart Server are integrated and assembled into an industrial panel. Necessary terminal blocks, CT short links, and MCBs are installed in the system for safety precautions. The MPM nodes are networked through RS485 and connected to the iLON Smart Server to provide web connectivity. The system is connected to the LAN and an IP address is assigned to the iLON server. The speed sensors are placed near the motor shaft and necessary shielded cables are used to connect to the system. For the power measurement of the individual motors, the PT & CT connections are taken from the control panel. Fig. 15 shows the screenshots of the web pages during its operations.



(a)



(b)

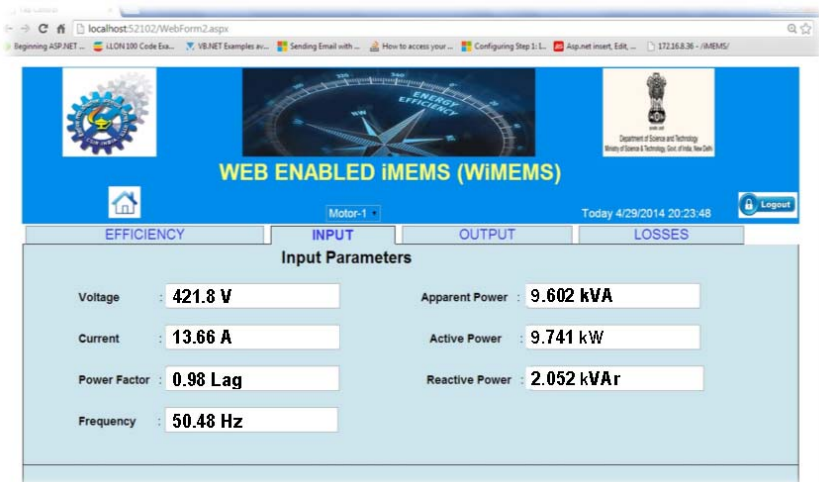

(c)



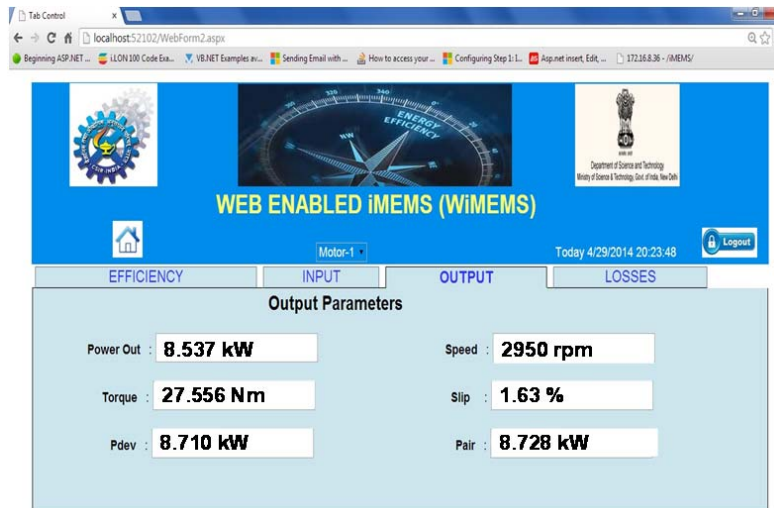

(d)

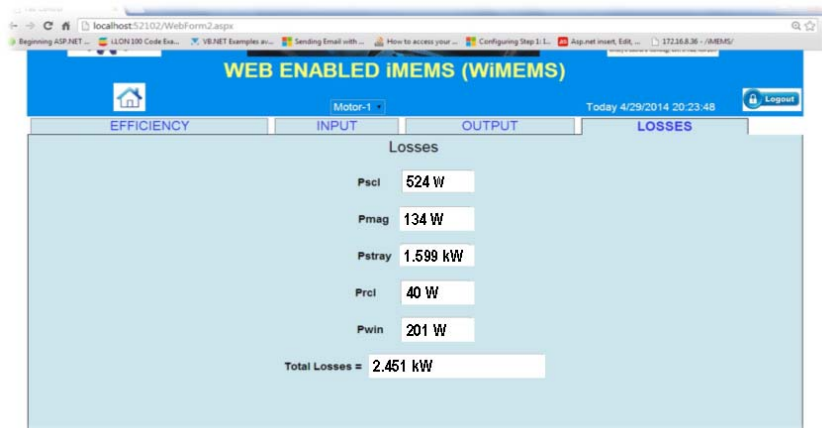

(e)

Fig. 15 View of web pages during operation

#### IV. CONCLUSION

iLon Smart Server based Remote Monitoring System for Induction Motors for monitoring the performance of motors on-line, on-site and in-situ on continuous operation is developed successfully and evaluated. The developed system is also field-trialed at many industries that include engineering industries, cement industries, water supply schemes, and Universities. The results obtained during the field-trials are very much satisfactory for the industries. This system can become a part of MAM System in future.

#### ACKNOWLEDGMENT

We sincerely thank Prof. R. K. Sinha, Director, CSIR-CSIO Chandigarh for his unstinted support and allowing us to undertake such a challenging work at CSIR-CSIO Chennai Centre. We also extend our gratitude to Dr. Anita Aggarwal, Scientist-E for her support extended to execute this work. We also acknowledge our industrial partner M/s BETA Technologies (I) Private Limited, Coimbatore and M/s

Industrial Controls & Drives (I) Private Limited, Chennai.

#### REFERENCES

- [1] "Total Primary Energy Production 2014", International Energy Statistics.
- [2] Statistical report presented by Bureau of Energy Efficiency (BEE) through "Standards & Labeling (S&L) Program for Motor in India", in MEPSA 2009
- [3] Bruno De Wachter, "Application Note – Electric Motor Asset Management", European Copper Institute, Publication No: Cu0104, Issue: 02, August 2011. [www.leonardo-energy.org/node/6186](http://www.leonardo-energy.org/node/6186)
- [4] Yang, M., "Energy efficiency policy impact in India: case study of investment in industrial energy efficiency. In: Energy Policy, 34 (17), 2006, pp. 3104-3114.
- [5] Ayyappan. G.S et.al., "Design and Development of on-Line, on-Site, in-Situ Induction Motor Performance Analyser", World Academy of Science, Engineering and Technology (WASET), International Journal of Energy and Power Engineering, Vol. 11, No. 1, 2017.
- [6] G. S. Ayyappan et. al, "Genetic algorithm based on-site Induction Motor Efficiency Monitoring Systems", Journal of Instrument Society of India, Vol. 39, No. 4, pp. 280-282, December 2009.
- [7] T. Phumiphak and C. Chat-Uthai, "Estimation of Induction Motor Parameters Based on Field Test Coupled with Genetic Algorithm", Proceedings of 2002 International Conference on Power System

Technology, PowerCon 2002, vol. 2, Kunming, China, Oct. 2002, pp. 1199–1203.

- [8] Jafar Mohammadi, Mohammad B.B. Sharifian, Khalil Banan, "Induction Motor Efficiency Estimation using Genetic Algorithm", Proceedings of World Academy Of Science, Engineering and Technology, January 2005, Volume 3, ISSN 1307-6884.
- [9] iLon Smart Server 2.2 FT, Echelon Corporation, <https://www.echelon.com/products/smartservers>
- [10] Sadik Tamboli, Mallikarjun Rawale, Rupesh Thoraiet and Sudhir Agashe, "Implementation of Modbus RTU & Modbus TCP Communication using Siemens S7-1200 PLC For Batch Process", International Conference on Smart Technologies and Management for Computing, Communication, Controls, Energy and Materials, 2015, pp. 258 - 263.
- [11] "IEEE Standard Test Procedure for Polyphase Induction Motors and Generators", IEEE 112 Standards, 2004.
- [12] "Guide for the use of Electric Motor Testing Methods Based on IEC 60034-2-1", May 2011, Version 1.1, Electric Motor Systems, Annex (EMSA) Task C – Testing Centers.
- [13] "Unlocking National Energy Efficiency Potential (UNNATEE)", Bureau of Energy Efficiency, Ministry of Power, Govt. of India, February 2019.



**Ayyappan G.S.** born in Pattiveeranpatty, Dindigul Dist., TamilNadu, India on the 4<sup>th</sup> June 1972. He did his schooling in Pattiveeranpatty and Diploma in Electrical & Electronics Engineering from P.A.C. Ramasamy Rajas Polytechnic, Rajapalayam, Tamilnadu, India during 1987-90 and stood State first rank. Later he did his undergraduate degree in Electrical & Electronics Engineering from Anna University, Chennai, India during 1998-2001 and recipient of University Gold Medal and General Proficiency Award conferred by the University; Later he did M. Tech., in Electronics & Control Engineering from Satyabhama University, Chennai, Tamilnadu, India during 2007-09 and received the University Gold Medal. At present, he is pursuing Ph.D. with the dissertation title Motor Asset Management on Continuous Operation from AcSIR-CECRI, Karaikudi, Tamilnadu, Chennai.

He started his profession as Junior Technical Assistant at CSIR-Central Scientific Instruments Organisation (CSIO) during 1990 and presently he is a Principal Scientist. Also, he is contributing in the academic field as Associate Professor at AcSIR-SERC-Renewable Energy program. Recently, he has completed a DST funded project titled "On-line, on-site and in-situ Induction Motor Efficiency Monitoring System" and developed the technology called Induction Motor Efficiency Monitoring System (IMEMS). The developed technology is transferred to two Indian firms for its commercialization. At present, he is heading a DST funded project titled "In-situ and non-intrusive Motor Stethoscope for monitoring the health of Induction Motor" and "Life Cycle Assessment of induction motors on continuous operations". He holds three international patent rights and one Indian Patent in the field of Energy Monitoring and Control Systems. He has transferred more than 10 technologies to the industries for commercialization. He has about 20 research papers published in the international & national journals in the area of energy management instrumentations and signal processing. He presented more than 30 papers in National & International Conferences, Symposiums and Workshops. He has delivered about 200 lectures to the student's community of Engineering and Arts & Science Colleges in India. He bagged two National level best paper awards conferred by ISOI, Bengaluru, India. His area of interests are embedded solutions, metering & industrial networking in the area of energy management instrumentation and achieving energy efficiency through motors and pumps in industries.

Mr. Ayyappan has many academic awards, distinctions, and scholarships to his credit including the Raman Research Fellowship award for the year 2011-12 instituted by CSIR. Indira Gandhi Sadbhavana Gold Medal Award, Bharat Ratna Dr. Abdul Kalam Gold Medal Award, Bharat Ratna Dr. Radhakrishnan Gold Medal Award and Padma Jyoti Gold Medal Award for the outstanding individual contribution in the field of Engineering & Research and Life Time Achiever Award from Sree Dharma Saastha Trust, Chennai & Rotary Club, Edappadi. He visited Lawrence Berkeley National Laboratory (LBNL), Berkeley, California, USA for the period of 4-months under deputation. He has 28 plus years of mammoth splendid experience in R&D in the fields of scanning tunneling microscopy, process control instrumentation, biomedical instrumentations and energy management instrumentation.



**Raja Raghavan M.** born in Chennai on 6<sup>th</sup> October 1991. He has completed his bachelor degree in Electronics and Instrumentation Engineering from Jeppiaar Engineering College, Anna University, Chennai, India in April 2013 and Master degree in Control & Instrumentation Engineering from Easwari Engineering College, Anna University, Chennai, India in May 2015.

He is also pursuing his Ph.D on condition monitoring on Electrical machines in Anna University, Chennai from January 2018.

He worked in the position of Junior Research Fellow at CSIR-CSIO Chennai Centre, Taramani, Chennai and presently he is working as Senior Research Fellow at CSIR-CSIO Chennai Centre, Taramani, Chennai. He is well-versed in Embedded C, C++, C#, Hardware Design and Simulation. He presented two papers in the international conference and five papers in the national conferences.

Mr. Raja Raghavan has been awarded CSIR Fellowship. He also received first prize for his paper presented in the national level professional conference. He has the expertise in the field of energy instrumentation and motor efficiency monitoring system. Presently, he is working in the development of Condition Monitoring of Induction Motor using hybrid techniques. He is a national level football player and has played many tournaments for the college and won many prizes.



**Poonthalir R.** born in Virudhunagar on 13<sup>th</sup> November 1994. She obtained her bachelor degree in Electronics and Communication Engineering from Kamaraj College of Engineering and Technology, Virudhunagar, India in 2016 and master degree in Embedded System Technologies from College of Engineering, Guindy campus, Anna University, Chennai, India in 2018.

Ms. Poonthalir is presently working as Project Assistant at CSIR-CSIO Chennai Centre, Taramani, Chennai, India. She is involved in the design and development of hardware and software systems for Condition Monitoring of Induction Motor using hybrid techniques. She is also responsible for the implementation of signal processing techniques & MATLAB simulation. She has presented a paper in the international conference.



**Prof. Srinivas Kota**, born at Gundur, India on 3<sup>rd</sup> November 1960. He obtained his M.Sc (Tech) from Regional Engineering College, Warangal, India in 1983 and M.S degree in Electronics & Control Engineering branch from BITS, Pilani during the year 1994.

He joined as Scientist-B at CSIR-Central Electronics Engineering Research Laboratory (CSIR-CEERI) in 1984 presently he is Chief Scientist at CSIR-Central Scientific Instruments Organisation (CSIO) Chennai Centre & heading the Chennai Centre as Scientist-in-charge. He is also a faculty in Academy of Scientific & Innovative Research (AcSIR), Renewable Energy course as Professor in India. He got 32 years of R&D experience and worked on various projects in the level of team members and leaders in field of energy management instrumentation, process control instrumentation, bio-sensor based instrumentation for health etc. He has got 11 national & international research papers published and one patent in his credit. He has transferred 7 technologies to the industries. He has presented more than 50 papers in the conferences and published about 5 reports. His areas of expertise are embedded systems & electronics in the field of energy management instrumentation and process control instrumentation.

Prof. Srinivas has got more awards in his credits; DAAD fellowship award and deputed to The Federal Army University, Munich, Germany for the period of two years from 1992, NRDC (National Research & Development Centre) award as a team member for pH control system 1990, WIPO Award and CSIR technology Shield for 1992.



**Dr. B. Ramesh Babu**, born on 25th May 1966. He obtained his Bachelor degree in Mechanical Engineering from Coimbatore Institute of Technology, Coimbatore, India during 1987, and Ph.D. in Metallurgical Engineering from Banaras Hindu University, Varanasi during 1997. Later he obtained his M.Sc degree in Environmental Science from Bharathiar University, Coimbatore, India during 2010. He also obtained

PGDCA course on Hardware and Software from Madurai Kamaraj University, Madurai, India.

He joined CSIR Central Electro-Chemical Research Laboratory (CSIR-

CECRI), Karaikudi in 8th February 1989 and presently he is in the position of Senior Principal Scientist. He is also a coordinator and faculty in Academy of Scientific & Innovative Research (AcSIR) – CECRI, Karaikudi. He is holding a position of Dean, Centre for Education at CSIR-CECRI, Karaikudi His areas of expertise are Sustainable energy and environmental research, Green chemistry and Green Technology, Advanced treatment of water and industrial wastewater, Management of solid waste disposal and air pollution. Presently he is guiding two Ph.D. scholars at AcSIR-CECRI, Karaikudi.

Dr. Ramesh Babu is the recipient of DAAD Long-Term fellowship at Germany from June 1997 to Sept. 1998. He has 25 publications in the international journals and 12 publications in national journals. He has presented papers in 17 international conferences & 15 national conferences. He has received three best paper award.