

Design and Development of an Innovative Advertisement Display with Flipping Mechanism

Raymond Yeo K. W., P. Y. Lim, Farrah Wong

Abstract—Attractive and creative advertisement displays are often in high demand as they are known to have profound impact on the commercial market. In the fast advancement of technology, advertising trend has taken a great leap in attracting more and more demanding consumers. A low-cost and low-power consumption flipping advertisement board has been developed in this paper. The design of the electrical circuit and the controller of the advertisement board are presented. A microcontroller, a Darlington Pair driver and a unipolar stepper motor were used to operate the electrical flipping advertisement board. The proposed system has been implemented and the hardware has been tested to demonstrate the capability of displaying multiple advertisements in a panel.

Keywords—Advertisement board, microcontroller, stepper motor.

I. INTRODUCTION

COMMERCIAL advertising trend has experienced a great transformation in the past decade. From the static billboard and the mechanical advertising board, this industry has taken another step into the digital advertising. This form of advertising includes the use Liquid Crystal Display (LCD) panel and Light Emitting Diode (LED) display panel. These digital outdoor advertising has turned the old-fashioned outdoor advertising industry into a fast growing industry. These technologies however, are consuming a great amount of energy due to the requirement of auxiliary components such as computer, wireless communication unit and cooling equipment. Also, proliferation of the digital advertising will incur recyclability issues. [1]

Due to the increasing environmental awareness of the public, many companies are looking for environmental friendly and cost-effective solutions in their commercial advertising. For example, Fig. 1 shows an example of a mechanically moving billboard that is used to display multiple advertisements. The downside of this advertisement board is that the maximum advertisement that it can show are limited to three advertisements only.

In order to reduce the environmental impacts done by digital advertising and to overcome the limitation of a conventional mechanical moving billboard, this project was initiated based on the idea of Solari Board created by Remigio Solari. [2] The Solari Board was used in the airports to announce flight arrival and departure. [3] It was then evolved to the electro-mechanic flip clock that can be seen today.

Raymond K. W. Yeo*, P. Y. Lim, and Farrah Wong are with the School of Engineering & Information Technology, Universiti Malaysia Sabah, Kota Kinabalu, Malaysia (e-mail: lpy@ums.edu.my).



Fig. 1 A advertisement board with rotating sections

By introducing the flipping mechanism into the world of outdoor advertising, it will be able to attract pedestrians to notice the flipping effects, sounds and hence, the advertisement itself. The advertisement board developed in this paper can display five or more advertisements. There is only a small amount of power used when the display is in the static mode. The proposed advertising system can be a low-cost sustainable solution due to the minimal quantities of electronic components required.

II. SYSTEM COMPONENTS

A. Mechanical Components

The mechanical structure of the system consists of the gears, split slaps and shaft as shown in Figs. 2 (a) and (b). The split slap is used as the base of the advertisement. The slap dimension is approximately 50mm x 30mm x 2mm. The slap must be durable especially on the small tip of both side of the slap. Those tips will be holding the whole slap onto the sprockets. Fig. 3 shows the physical set-up of the proposed system.



Fig. 2 (a) Plastic, 70 teeth, 3.5cm diameter gear

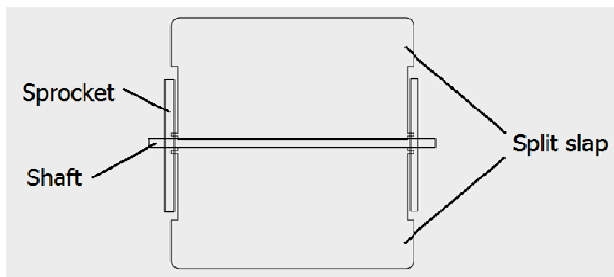

Fig. 2 (b) The front view of the split slap



Fig. 3 The front view of the electrical flipping advertisement board

The gear used in electrical flipping advertisement board is the 70 teeth, 3.5cm diameter and plastic type gear. Five gears of the same size and ratio was used in the rotating the shafts. Fig. 4 shows the arrangement of the gears used in the rotating mechanism from top to bottom. When all the ratio and size of the gears is the same, the rotation each shafts can be synchronised as well. The 70-teeth gears can provide better precision of angle of rotation driven by the stepper motor. Notice that the stepper motor was placed on the middle row. This is to ensure the load is evenly distributed to the top and bottom row. If the motor is placed in top or bottom row, friction produced will be higher on the either end compare when placed at the middle row.

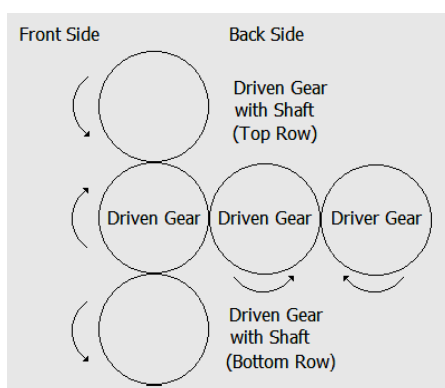

Fig. 4 The arrangement of the gears

B. Electrical Components

The core component of the proposed system is a stepper motor. A stepper motor is controlled using electrical pulses generated by a control unit to provide mechanical shaft rotation. It is able to perform accurate positioning by rotating a shaft to a precise angle. [4] It is a high reliability device and it has high torque at low speed.

In this paper, the stepper motor system constitutes of four sections as shown in Fig. 5. They are the user interface, controller, driver and the motor itself. The motor can be controlled by a micro-controller that is capable of generating step pulses and direction signals for the driver.

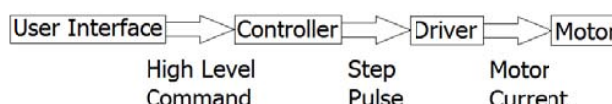

Fig. 5 Stepper motor system

A micro-controller PIC16F877A [5] was adopted to generate signals to the motor driver. The ULN2003 high voltage and high current 7-channel Darlington Transistor array was used as the driver for the motor. [6] The pin connection of the driver is arranged as in Table I. The driver controls the output voltage and current depending to the signal received from the controller.

TABLE I
PIN CONNECTION FOR PIC16F877A

Pin	Connection to
2 (RA0)	1B (ULN2003-1) 2B (ULN2003-1)
3 (RA1)	3B (ULN2003-1) 4B (ULN2003-1)
4 (RA2)	1B (ULN2003-2) 2B (ULN2003-2)
5 (RA3)	3B (ULN2003-2) 4B (ULN2003-2)
11 (VCC)	+5V Supply
12 (GND)	GND
15 (RC0)	Button 'A'
16 (RC1)	Button 'B'
17 (RC2)	Button 'C'
18 (RC3)	LED 1
23 (RC4)	LED 2
24 (RC5)	LED 3

The ULN2003 high voltage and high current 7-channel Darlington Transistor array is used as the driver for the motor. ULN2003 is a NPN Darlington pair that features high voltage output with common-cathode clamp diode for switching inductive loads. The collector current rating of a single Darlington pair is 500mA. The Darlington pair can be paralleled for higher current capability. Compare to the ULN2803, both have the same specifications except that the ULN2803 has one extra channel more than ULN2003.

The arrangement of the IC has Pin 1 to Pin 7 as the terminal to receive control signal. These are terminals are connected to the microcontroller. The output pins of the driver are Pin 13 to

Pin 16 and they are connected to the motor. Pin 9 is connected to the 12V voltage source. Table II shows the absolute maximum rating specification (at 25°C) of ULN2003 and the connections of the pins are listed in Table III.

TABLE II
SPECIFICATION OF ULN2003 DRIVER

Characteristic	Value
Collector Emitter Voltage, V_{CE}	50V
Input Voltage, V_I	30V
Peak Collector Current, I_O	500mA
Total Emitter-terminal	500mA
Power Dissipation, P_d	950mW (at 25°C ambient temperature) 495mW (<85°C ambient temperature)
Operating Temperature	-20°C to +85°C

TABLE III
PIN CONNECTION OF ULN2003 DRIVER

Pin	Connection to
1 (1B)	RA0 (PIC)
2 (2B)	RA1 (PIC)
3 (3B)	RA2 (PIC)
4 (4B)	RA3 (PIC)
8	GND
9(Common)	+12V
13 (1C)	Yellow (Motor)
14 (2C)	Blue (Motor)
15 (3C)	Red (Motor)
16 (4C)	Green (Motor)

The stepper motor adopted is the LINIX 42BYGHD439-02 stepper motor. [7] Table IV shows the specification of the motor and Fig. 6 shows the simple diagram of this unipolar stepper motor. From the physical view, the dimension of motor is 42mm x 42mm x 39mm. It has 6 lead wires where black and white are the common wires while blue, green, red and yellow are the coil end wire. Each coil or phase is 7.5Ω and 2 phases are serially connected, giving a total of 15Ω from coil end to another. The common wires are to be connected with the +12V supply and the rest of the lead wires are to be connect into the output of the driver. This motor's lead wires is arrange as Green, Red, Blue and Yellow for Phase 1 until Phase 4 respectively.

The actual speed of the stepper motor is dependent on the step angle and step rate from the bottom equation. Hence, the RPM of the motor is controllable depending on the step rate and the step angle as given in (1).

$$MotorSpeed(RPM), N = \frac{\varphi(ns^{-1})}{6} \tag{1}$$

where,

φ = stepangleindegree

n = number of step

The rotation of the stepper motor can be adjusted to display more advertisements. The step angle of the stepper motor has to be taken into the consideration. Since the motor is only operating at 1.8°, the number of advertisements compatible with this stepper motor is listed in Table V.

TABLE IV
LINIX42BYGHD439-02 SPECIFICATION [7]

Characteristic	Value
Nominal Voltage	12V
Current	0.8A
Phase	4
Resistance	7.5Ω
Holding Torque	2.5kg.cm
Lead wire	6
Step angle	1.8° ±5%

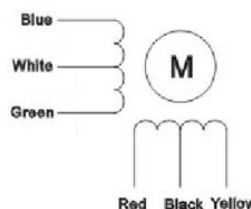

Fig. 6 Unipolar coil winding

TABLE V
NUMBER OF ADVERTISEMENTS AND STEP ANGLE

No. of advertisement	Degree per advertisement	Motor Step
5	360°/5 = 72°	72°/1.8° = 40 steps
10	360°/10 = 36°	36°/1.8° = 20 steps

C. Physical Connections

The schematic of the proposed system consists of two main parts, mainly the input user interface module as well as the driver module. This modular design was created in order to ease the design of the schematic as well as the soldering processed. Any fault in connection can also be traced easily also. Another reason of the modular design is to ease the placement of these circuits to the project structure. Fig. 7 shows the layout of the stripboard for the input user interface switch buttons and Fig. 8 depicts the layout of the driver module. The 'X' marking indicates that the copper in on the stripboard was separated using drill bit to avoid short circuit. The bolded vertical lines represent the wires or jumpers.

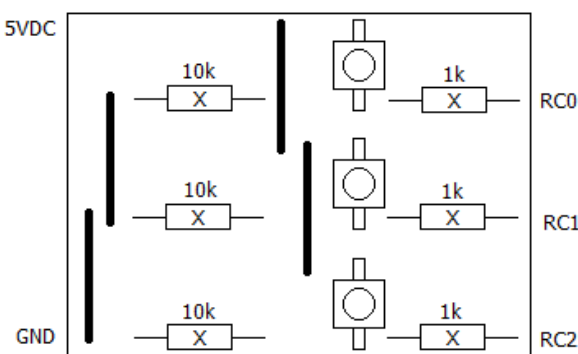

Fig. 7 Stripboard diagram of input user interface module

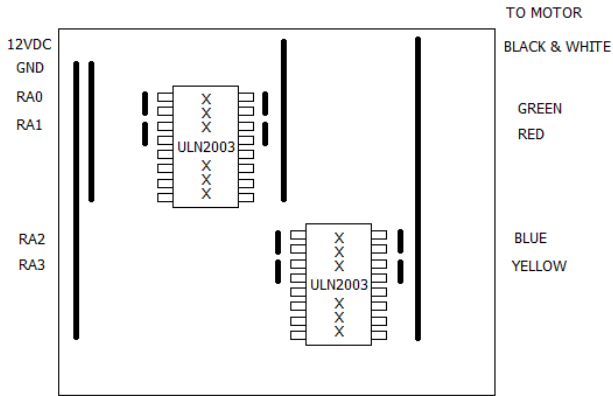

Fig. 8 Stripboard layout for driver module

III. SIMULATION

The electric circuit diagram of the proposed advertisement board is shown in Fig. 9. At the upper left corner of Fig. 9 are two ULN2003 motor drivers that receive signals from the PIC microcontroller. The LCD display and three buttons at the upper right corner are used for user interfacing purposes. Fig. 10 shows the signals generated from the micro-controller to operate the stepper motor in the PROTEUS simulation software. The speed of the motor can be changed by adjusting the delay time for each pulse being sent into the driver. In Fig. 10, each pulse width is 74ms. In 1 minute, total pulse sent was 810 pulses. The pulses are equivalent to the number of steps move by the rotor. To complete one revolution, it takes 200 steps for the wave drive. Hence, this motor is running at 4.05 revolution per minute (RPM). The revolution per minute at the same delay time for the programming of half step drive is only 2.02 RPM. The speed of the rotation can be adjusted by changing the output step pulse in the programming codes.

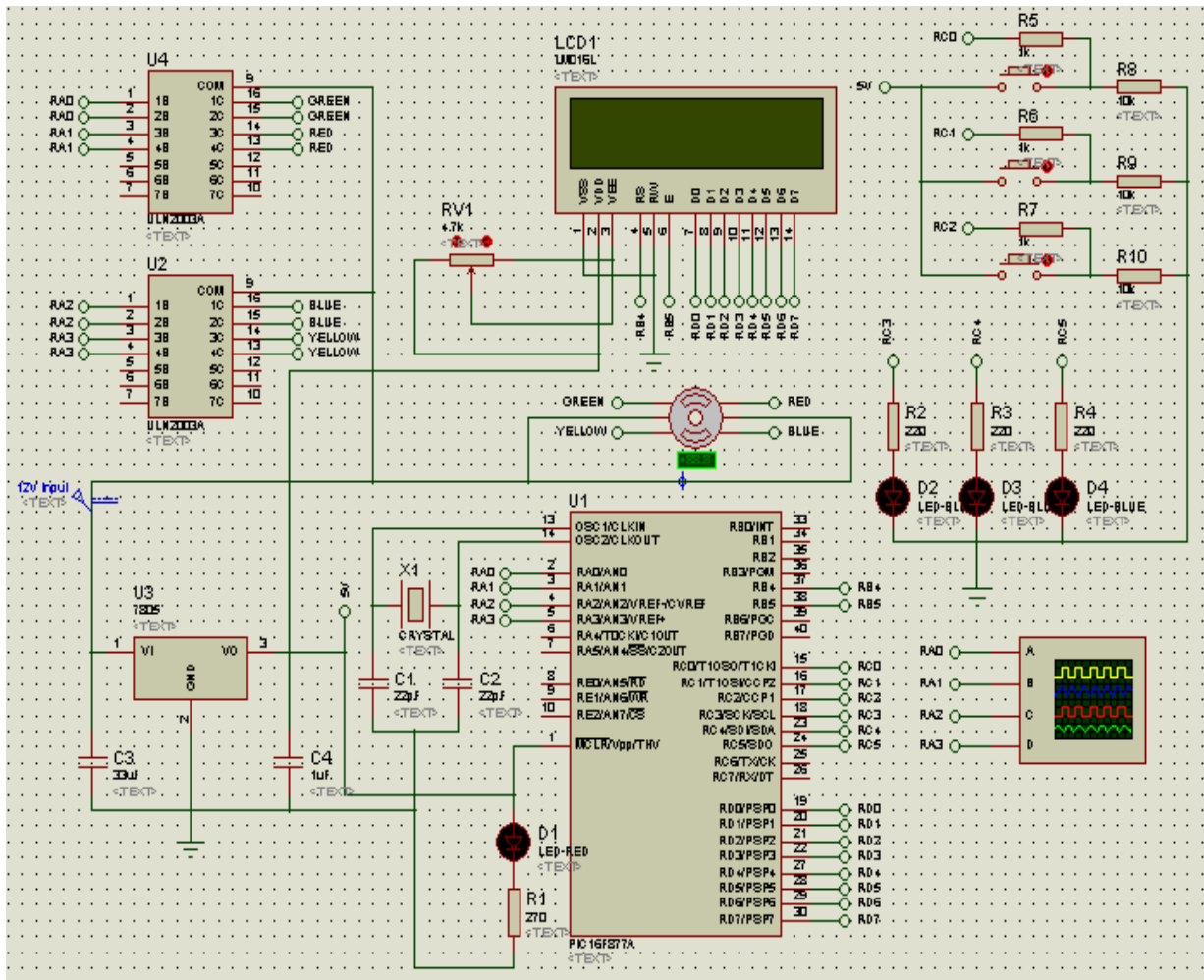

Fig. 9 Schematic diagram of the proposed microcontroller based flipping advertisement board

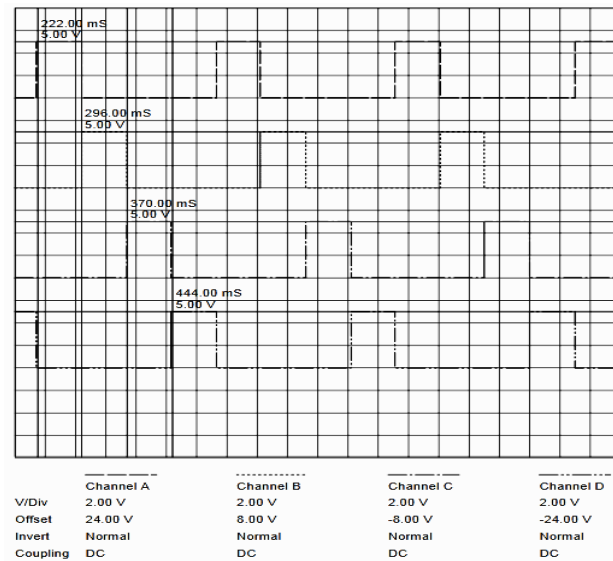

Fig. 10 Output signals from the micro-controller to operate the stepper motor

From the simulation result, there are total of four waveforms in the two coils of the stepper motor. Since this stepper motor uses unipolar coil winding, it has total of 6 lead wires where 4 wires (namely Green, Red, Blue and Yellow) used for driving the motor. The result shows the wave drive output waveform from the micro-controller, which is 5V signal that will trigger the ULN2003 driver to move the motor. The arrangement of the waveforms is shown from top to bottom Yellow, Blue, Red and Green respectively. In other word, the system is driving the motor in anti-clockwise just as needed to flip the flaps over.

IV. EXPERIMENTAL RESULTS

Fig. 11 shows the microcontroller LCD display and three buttons used to change the mode of operation of the proposed system. The power supply for the PIC was supplied from the USB cable directly from laptop. USB can supply 5V DC with a range of 100mA to 500mA. As for the motor and the driver, an external 12V DC adapter was used as power supply. The connection of the microcontroller to the stepper motor is shown in Fig. 12.

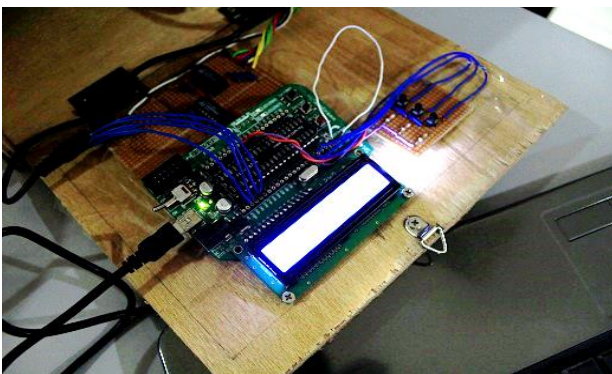

Fig. 11 The user interface of the system

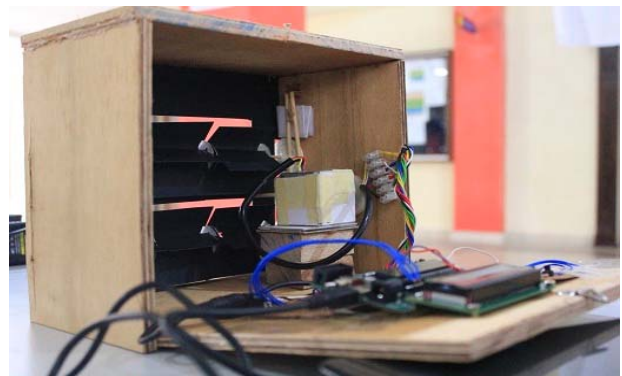

Fig. 12 The back view of the electrical flipping advertisement board

The signals from the PIC micro-controller were measured to ensure that the wave drive signal to the driver is as the simulated results. The output signal consists of 5V pulses which represent the on-states. Each pulse that is sent to the stepper motor was in sequence just like the wave drive signal but in anti-clockwise rotation. In this way, the motor will be constantly moving in a single direction only. The output signals obtained from the PIC micro-controller are shown in Fig. 13. The waveforms were captured when the wave drive signal was send to the motor. From the waveform shown in result section, the time for each pulse was showing to approximate of 74ms.

The upper waveform in Fig. 13 is the output from pin RA0 of the micro-controller, while the lower waveform is from pin RA1. The pulse from RA1 came in first and as the RA1 signal goes to zero. The signal is generated in this sequence in order to operate the stepper motor to rotate in counter clockwise. The stepper motor needs for at least of 40 pulses or steps to flip to the next advertisement, meaning that 72° of rotation is required to display the next advertisement.

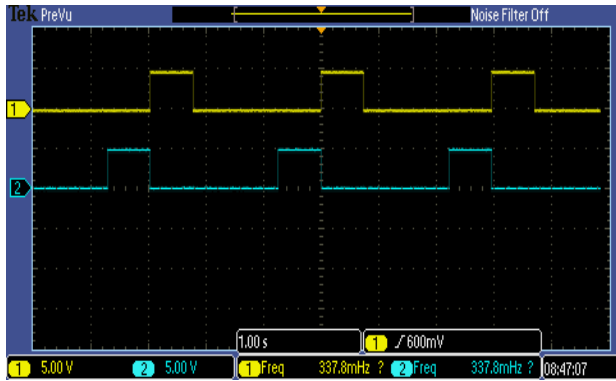

Fig. 13 The output signal of the PIC

The proposed advertisement board has the flexibility to allow the users to select the mode of operation. Two modes of operation are available, namely the fast mode and the slow mode. In the fast mode operation, the duration of displaying an advertisement is set to 10 seconds, where the advertisement board is in static condition. The upper board of each row will be flipped down once the duration set-point is reached. The flipping process lasts for 5 seconds.

The power consumption of the proposed advertisement board has been measured using an ARLEC Energy Meter. During the flipping phase, the peak power consumption reached 28W, whereas during static phase, only 1W of power consumption is measured.

V. CONCLUSION

In this paper, a flipping advertisement board that could display multi-advertisement has been developed and tested. The system consists of simple mechanical structure and reliable stepper motor and control unit. The experiment set-up has demonstrated the capability of the system to display of multiple advertisements compared to a static board. The proposed flipping advertisement system could definitely emerge as a low cost and feasible solution for indoor and outdoor advertising. In addition, it is also superior to the electronic advertising due to lesser auxiliary components required and lower energy consumption when the board is in the static mode.

ACKNOWLEDGMENT

We would like to express our deepest gratitude and appreciation to the School of Engineering & Information Technology, Universiti Malaysia Sabah for the financial support provided for this project.

REFERENCES

- [1] Young, G. "Illuminating the Issues – Digital Signage and Philadelphia's Green Future", Retrieved from: <http://www.scenic.org/resources/studies-and-reports/digital-billboard-studies>
- [2] Solari, R. "Electromechanic Wall Calendar Clock", 1954, Retrieved from <http://www.google.com/patents/US2667735>
- [3] "Split-flap display", Retrieved from: http://en.wikipedia.org/wiki/Split-flap_display

- [4] Chapman S. J., "Electric Machinery Fundamentals", McGraw-Hill, Fifth Edition, 2012.
- [5] Microchip Technology Inc. "PIC16F87XA Data Sheet". Retrieved from <http://ww1.microchip.com/downloads/en/devicedoc/39582b.pdf>
- [6] ST Microelectronics, "Seven Darlington Array", 2012, Retrieved from www.st.com
- [7] Cytron Technologies Catalogue, 2009, Retrieved from www.cytron.com.my