

# Design and Control of DC-DC Converter for the Military Application Fuel Cell

Tae-Yeong Lee, Eun-Ju Yoo, Won-Yeong Choi, and Young-Woo Park, *Member, IEEE*

**Abstract**— This paper presents a 24 watts SEPIC converter design and control using microprocessor. SEPIC converter has advantages of a wide input range and miniaturization caused by the low stress at elements. There is also an advantage that the input and output are isolated in MOSFET-off state. This paper presents the PID control through the SEPIC converter transfer function using a DSP and the protective circuit for fuel cell from the over-current and inverse-voltage by using the characteristic of SEPIC converter. Then it derives them through the experiments.

**Keywords**—DC-DC Converter, Fuel-Cell, Microprocessor Control, Military Converter, SEPIC Converter

## I. INTRODUCTION

THE fuel cell is receiving great interest recently as an alternative energy source. Existing batteries charging problems due to the military equipment is not appropriate. Due to this, the research has been going on which this alter to fuel-cell. The fuel cell has a slow response, and therefore the power demand from the load and the power supply from the fuel cell do not coincide during a transient load [1]. Therefore, the use of fuel cell as possible, and sulfur stable power conversion device is required. In this paper, DC-DC converter design and control have been researched for the military portable equipment which satisfies 24 watts, 12 voltages output fuel cell that requires needed output and consider the characteristic of fuel cell.

DMFC stacks used in the fuel cell pack output nonlinearly (Fig. 1) and need preheating period in beginning operation. For this period, the output is unstable (Fig. 2). Existing DC-DC converters can work out nonlinear output but this paper presents a novel converter control method using 32bit microprocessor to make converters small which have a protective function of fuel cell battery and a cutoff-output function in preheating.

This work was supported by the Next Generation Military Battery Research Center Program of Defense Acquisition Program Administration and Agency for Defense Development.

T. Y. Lee is with BK21 Mechatronics Group, Graduate School at Chungnam National University, Daejeon, Korea 305-764 (e-mail: kdemcr@nate.com).

E. J. Yoo is with BK21 Mechatronics Group, Graduate School at Chungnam National University, Daejeon, Korea 305-764 (e-mail: hcwsj5@naver.com).

W. Y. Lee is with BK21 Mechatronics Group, Graduate School at Chungnam National University, Daejeon, Korea 305-764 (e-mail: cwr0614@naver.com).

Y. W. Park is with the Department of Mechatronics Engineering Chungnam National University, Daejeon, Korea 305-764 (phone:+82-42-821-6874, fax:+82-42-823-4919, e-mail: ywpark@cnu.ac.kr).

The SEPIC converter which is a type of inductive energy storage converter is similar to a buck-boost converter in producing stable output regardless of its fluctuation of input voltage to output voltage, and has an advantage that the input isolates from the output. Using this, fuel cell battery can be protected for the inverse voltage at the output by applying MOFET without any additional circuit.

A transfer function is gotten through the small signal analysis of the SEPIC converter, based on that controller is designed. A transfer function which is an important design element is determined according to converter. When a control transfer function determined, then a controller is designed. It has additional protective functions of inverse voltage and over discharge.

This paper designed and experimented 24 watts, 12 voltages SEPIC converter using fuel cell stacks which follow the output of Fig. 1 as the power.

## II. DESIGN AND CONTROL OF DC-DC CONVERTER

### A. Fuel Cell Stack

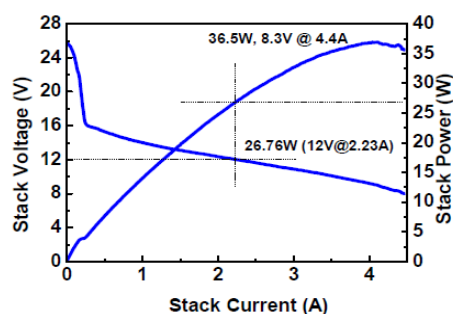

Fig. 1 Output of Fuel Cell Stacks

Fig. 1 shows the output of fuel cell stacks used in the fuel cell pack of the military application [2]. Having 8~30 voltages output region, the output decreases inversely according to the amounts of current in stacks. The output is 24 watts reaches to 24 watts as the 2 amperes load occurs.

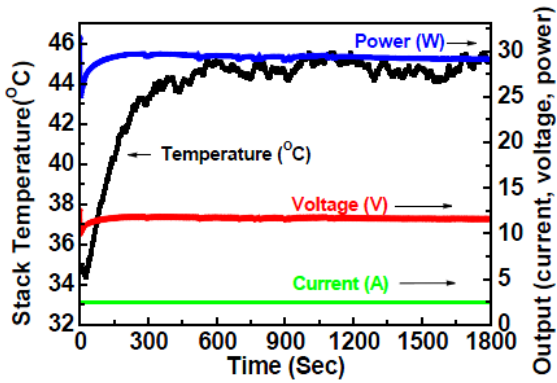

Fig. 2 Output of Fuel Cell Stacks with Temperatures

Fig. 2 shows the output of fuel cell stacks according to its temperature [2]. As shown in Fig. 2, fuel cell output is unstable from stack starting operation to after 3 minutes. Therefore it needs to confine the output by the end of preheating. By adding a temperature sensor to the microprocessor which controls the SEPIC converter, the function was added which confines current. A coupling capacitor between first and second inverters allows energy transition and protection of inverse voltage.

The power supplied from fuel cell stacks is rectified to 12 voltages output through the SEPIC converter. SEPIC converter controlled by a microprocessor prevents inverse voltage and over discharge by feeding back voltage and current from the resistance.

B. SEPIC Converter Analysis

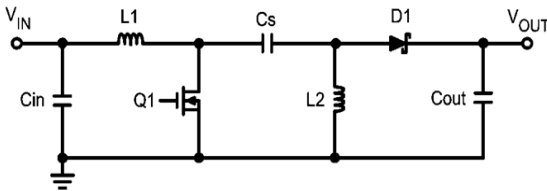

Fig. 3 Topology of SEPIC Converter

Fig. 3 shows a typical topology of a SEPIC converter [3]. It consists of inductors (L1 and L2), capacitors (Cin, Cout and Cs), a MOSFET (Q1) and a diode (D1). A microprocessor is connected to Q1, and used to control SEPIC converter was designed to be controlled. In order to control the SEPIC converter using a microprocessor, small signals of the converter are analyzed, and then transfer function should be obtained [4].

General state equations are expressed as

$$\begin{aligned} \dot{x} &= Ax + Bu \\ y &= Qx + Ru \end{aligned} \quad (1)$$

, where,  $\dot{x}$  = electric charge,  $y$  = output voltage,  $A$  = system

matrix,  $B$  = input matrix,  $Q$  = output matrix,  $R$  = direct transmission matrix and  $u$  = control input.

Equation (2) is the state equations for SEPIC converter. At this time, state transition of the SEPIC converter can be calculated twice: one is MOSFET-on; the other MOSFET-off

$$\begin{aligned} \dot{x} &= \left[ A_1 \frac{t_{ON}}{t_p} + A_2 \frac{t_{OFF}}{t_p} \right] x + \left[ B_1 \frac{t_{ON}}{t_p} + B_2 \frac{t_{OFF}}{t_p} \right] u \\ y &= \left[ Q_1 \frac{t_{ON}}{t_p} + Q_2 \frac{t_{OFF}}{t_p} \right] x + \left[ R_1 \frac{t_{ON}}{t_p} + R_2 \frac{t_{OFF}}{t_p} \right] u \end{aligned} \quad (2)$$

, where,  $t_{ON}$  = MOSFET-on,  $t_{OFF}$  = MOSFET-off and  $t_p$  = control period.

Fig. 4 shows the state while energy goes to inductors L1 and L2 at MOSFET-on [3]. The voltage on capacitor C1 increases toward negative direction while energy goes to inductors L1 and L2 by the input power. And the voltage on output side gets equal to the voltage on output capacitor C2. When get the state equation about the voltage of SEPIC converter, it's like Equation (3), (4) and (5).

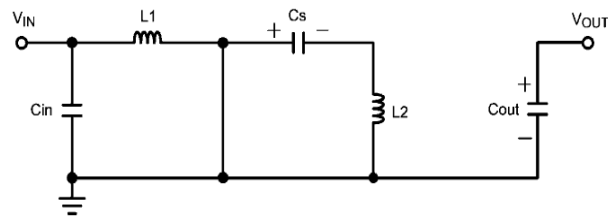

Fig. 4 SEPIC Converter during MOSFET-On

Equation (3) is input voltage state equation of MOSFET-on for SEPIC converter.

$$\begin{bmatrix} \dot{x}_1 \\ \dot{x}_2 \\ \dot{x}_3 \\ \dot{x}_4 \end{bmatrix} = \begin{bmatrix} 0 & 0 & 0 & 0 \\ 0 & 0 & \frac{1}{C_{in}} & 0 \\ 0 & -\frac{1}{L_2} & 0 & 0 \\ 0 & 0 & 0 & -\frac{1}{R \cdot C_s} \end{bmatrix} \begin{bmatrix} x_1 \\ x_2 \\ x_3 \\ x_4 \end{bmatrix} + \begin{bmatrix} \frac{1}{L_1} \\ 0 \\ 0 \\ 0 \end{bmatrix} V_{IN} \quad (3)$$

Equation (4) is output voltage state equation of MOSFET-on for SEPIC converter.

$$V_{OUT} = \begin{bmatrix} 0 & 0 & 0 & 1 \end{bmatrix} \begin{bmatrix} x_1 \\ x_2 \\ x_3 \\ x_4 \end{bmatrix} \quad (4)$$

From Equations (3) and (4),  $\dot{x}_1$ ,  $\dot{x}_2$ ,  $\dot{x}_3$  and  $V_{OUT}$  are obtained as

$$\dot{x}_1 = \frac{V_{IN}}{L_1}, \quad \dot{x}_2 = \frac{x_3}{C_{in}}, \quad \dot{x}_3 = \frac{x_2}{L_2}, \quad V_{OUT} = x_4 \tag{5}$$

, where, Equation (5) each voltage on the elements and the output voltage are independent each other [5].

Fig. 5 shows the state which the energy from L1, L2 inductors as MOSFET-off discharges and then supplies to the load [3]. As the energy discharges from inductors, diode S2 is on by induced voltage hence the voltage on output side gets equal to the voltage of inductors.

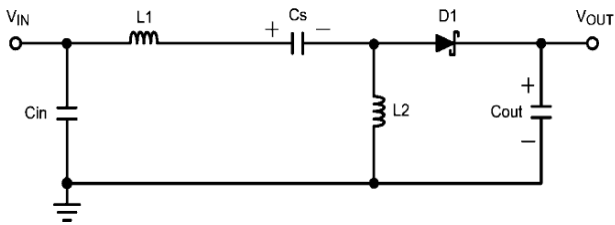

Fig. 5 SEPIC Converter during MOSFET-Off

Equations (6), (7) and (8) show the state equations about the induced voltage caused by the energy from inductors. Equation (6) is input voltage state equation of MOSFET-off for SEPIC converter.

$$\begin{bmatrix} \dot{x}_1 \\ \dot{x}_2 \\ \dot{x}_3 \\ \dot{x}_4 \end{bmatrix} = \begin{bmatrix} 0 & -\frac{1}{L_1} & 0 & -\frac{1}{L_1} \\ \frac{1}{C_{in}} & 0 & 0 & 0 \\ 0 & 0 & 0 & \frac{1}{L_2} \\ \frac{1}{C_s} & 0 & -\frac{1}{C_s} & -\frac{1}{R \cdot C_s} \end{bmatrix} \begin{bmatrix} x_1 \\ x_2 \\ x_3 \\ x_4 \end{bmatrix} + \begin{bmatrix} \frac{1}{L_1} \\ 0 \\ 0 \\ 0 \end{bmatrix} V_{IN} \tag{6}$$

Equation (7) is output voltage state equation of MOSFET-off for SEPIC converter.

$$V_{OUT} = \begin{bmatrix} 0 & 0 & 0 & 1 \end{bmatrix} \begin{bmatrix} x_1 \\ x_2 \\ x_3 \\ x_4 \end{bmatrix} \tag{7}$$

From Equation (6) and (7),  $\dot{x}_1$ ,  $\dot{x}_2$ ,  $\dot{x}_3$  and  $V_{OUT}$  are obtained as

$$\dot{x}_1 = -\frac{x_2}{L_1} - \frac{x_4}{L_1} + \frac{V_{IN}}{L_1}, \quad \dot{x}_2 = \frac{x_1}{C_{in}}, \quad \dot{x}_3 = \frac{x_4}{L_2}, \quad V_{OUT} = x_4 \tag{8}$$

, where, Equation (8) Output voltage is determined by the voltage of L1, L2 inductors. Equation (9) and (10) are the sum of state equation (5) and (8).

$$\begin{bmatrix} \dot{x}_1 \\ \dot{x}_2 \\ \dot{x}_3 \\ \dot{x}_4 \end{bmatrix} = \begin{bmatrix} 0 & 0 & 0 & 0 \\ 0 & 0 & \frac{1}{C_s} & 0 \\ 0 & -\frac{1}{L_2} & 0 & 0 \\ 0 & 0 & 0 & -\frac{1}{R \cdot C_{OUT}} \end{bmatrix} d + \begin{bmatrix} 0 & -\frac{1}{L_1} & 0 & -\frac{1}{L_1} \\ \frac{1}{C_s} & 0 & 0 & 0 \\ 0 & 0 & 0 & \frac{1}{L_2} \\ \frac{1}{C_{OUT}} & 0 & \frac{1}{C_{OUT}} & -\frac{1}{R \cdot C_{OUT}} \end{bmatrix} \dot{d} \begin{bmatrix} x_1 \\ x_2 \\ x_3 \\ x_4 \end{bmatrix} + \begin{bmatrix} \frac{1}{L_1} \\ 0 \\ 0 \\ 0 \end{bmatrix} d + \begin{bmatrix} \frac{1}{L_1} \\ 0 \\ 0 \\ 0 \end{bmatrix} \dot{d} V_{IN} \tag{9}$$

$$V_{OUT} = \begin{bmatrix} 0 & 0 & 0 & 1 \end{bmatrix} d + \begin{bmatrix} 0 & 0 & 0 & 1 \end{bmatrix} \dot{d} \begin{bmatrix} x_1 \\ x_2 \\ x_3 \\ x_4 \end{bmatrix} \tag{10}$$

From Equation (9) and (10), state equation is obtained as

$$\begin{aligned} \dot{x} &= \left[ A_1 d + A_2 \dot{d} \right] x + \left[ B_1 d + B_2 \dot{d} \right] u \\ y &= \left[ Q_1 d + Q_2 \dot{d} \right] x + \left[ R_1 d + R_2 \dot{d} \right] u \end{aligned} \tag{11}$$

, state equation about the SEPIC converter's continuous states is shown as equation (11). For the obtained state equation, the output transfer function according to MOSFET switching duty rate can be expressed as

$$\frac{V_{OUT}(S)}{d(S)} \approx \frac{1}{D^2} \frac{\left(1-s \frac{L_1 D^2}{R D^2}\right) \left(1-s \frac{C_{in}(L_1+L_2)R D^2}{L_1 D^2} + s^2 \frac{L_2 C_{in}}{D}\right)}{\left(1+\frac{s}{\omega_1 Q} + \frac{s^2}{\omega_1^2}\right) \left(1+\frac{s}{\omega_2 Q_2} + \frac{s^2}{\omega_2^2}\right)} \quad (12)$$

, where,

$$\omega_1 \approx \frac{1}{\sqrt{L_1 \left(C_s \frac{D^2}{D^2} + C_{in}\right) + L_2 (C_{in} + C_s)}} \quad (13)$$

$$\omega_2 \approx \sqrt{\frac{1}{L_2 \frac{C_{in}}{D^2} \square \frac{C_s}{D^2}} + \frac{1}{L_1 C_{in} \square C_s}}$$

$$Q_1 \approx \frac{R}{\omega_1 \left(L_1 \frac{D^2}{D^2} + L_2\right)}$$

$$Q_2 \approx \frac{R}{\omega_2 (L_1 + L_2) \frac{C_{in}}{C_s} \omega_2^2}$$

The controller is designed through the obtained equation (12).

C. Control Using the Microprocessor

For the control SEPIC converter, this paper uses the DSP28335 processor. DSP processor is proper to apply for fuel cell pack of the military use because it has high-speed processing for the signal process and guarantees the operation of low temperature from -40 to 125 degrees.

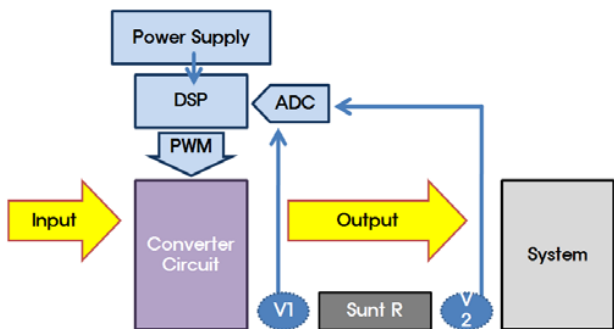

Fig. 6 Control Block Diagram of SEPIC Converter

Fig. 6 shows the SEPIC converter control block diagram using a microprocessor. The output voltage and current are estimated by the shunt resistance R. The processor uses the estimated voltage as a SEPIC converter control feed-back and the estimated current as a protective feed-back of the fuel cell stacks over-current.

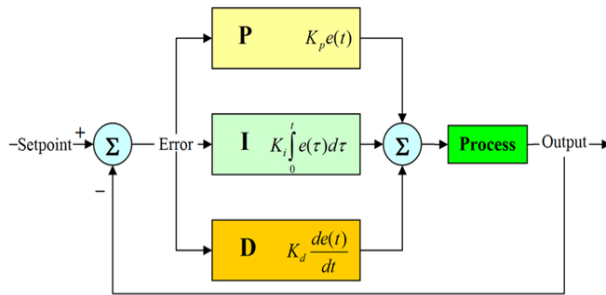

Fig. 7 PID Control Loop of SEPIC Converter

Fig. 7 shows PID control loop. Control loop is completed by using zigler-nicols method and obtaining gains based on the transfer function in equation (6). Also, in the case of inverse voltage and over-current as the amounts of the voltage and current feed-back, MOSFET will be off then it can protect the fuel cell stacks.

D. Fabrication

Fig. 8 shows the developed 24 watts SEPIC converter. Fig. 9 shows the experimental control board.



Fig. 8 SEPIC Converter

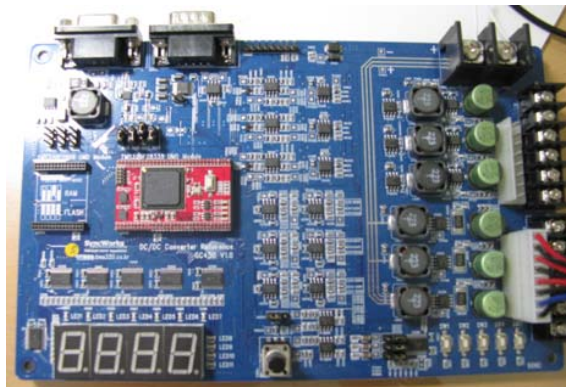

Fig. 9 Control Board

III. THE EXPERIMENT RESULT

TABLE I  
SETTING OF THE SEPIC CONVERTER

Parameters	Unit	Value
Input Voltage	V	8-28
Output Voltage	V	12
Max load current	A	2
Max power	W	24
Switching frequency	kHz	100

Table I shows the setting of the experiment circuit. The experiment is about the characteristic of the output voltage and the circuit protective function.

Fig. 10 shows the output voltage as the loads. According to respectively load in compliance with the characteristic of fuel cell the input voltages are different as each load, but the outputs are constant with 12 voltages.

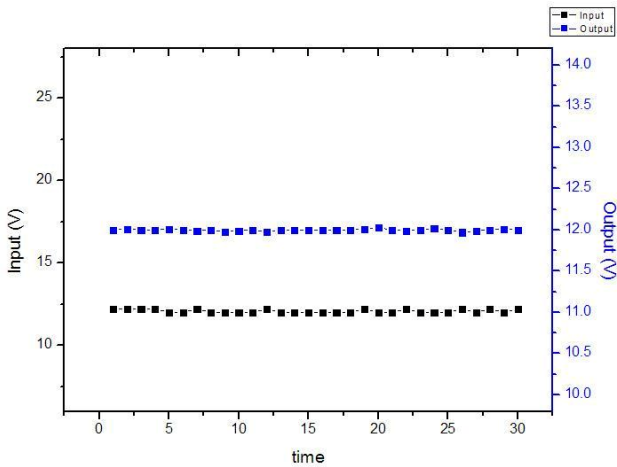

(a) The average Output: 12.2V 2.292A

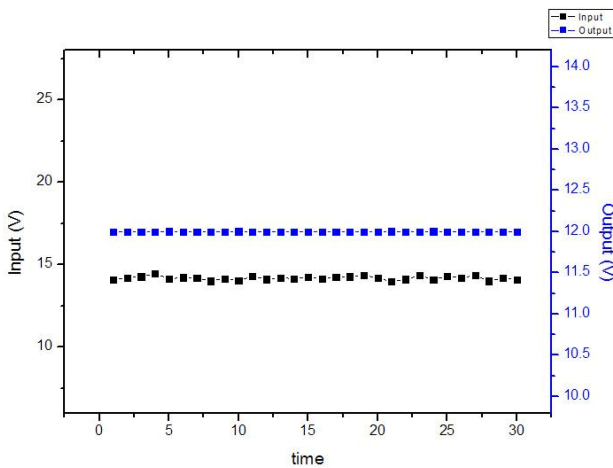

(b) The average Output: 14.3V 0.96A

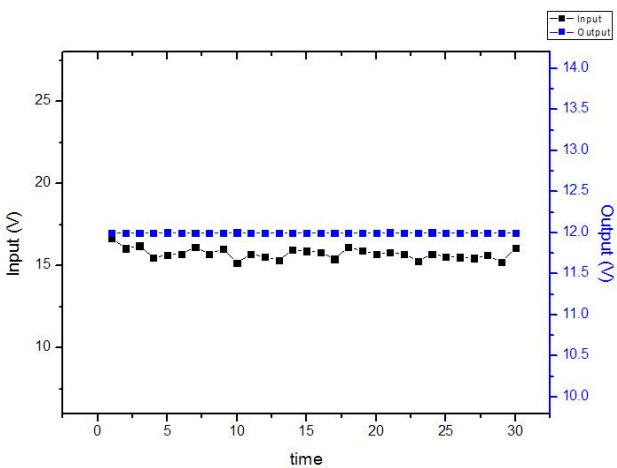

(c) The average Output: 15.8V 0.448A

Fig. 10 Fuel Cell Application of SEPIC Converter

TABLE II  
FUEL CELL APPLICATION EXPERIMENT OF SEPIC CONVERTER

<i>Fuel-Cell</i>		<i>SEPIC Converter</i>		<i>Efficiency</i>
V	A	V	A	%
12.2	2.292	12	1.886	80.94
14.3	0.96	12	0.927	81.03
15.8	0.448	12	0.482	81.71

Table II shows the output power according to the power from fuel cell and the accuracy calculated by the amounts of current at that time. These all satisfy the accuracy over 80% which fuel cell pack of the military use needs.

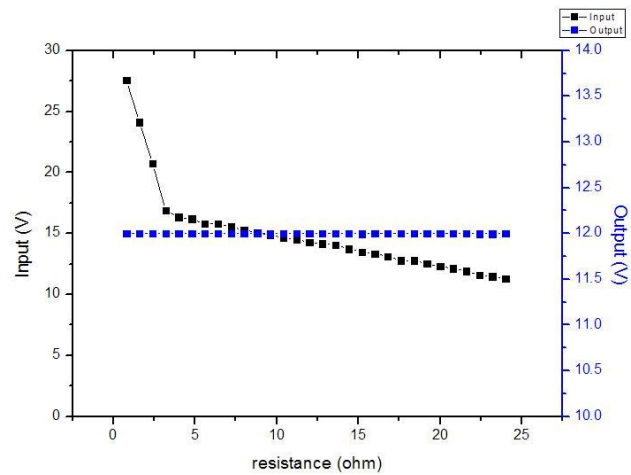

Fig. 11 Fluctuating Load Conditions, the Output Voltages and Current of SEPIC Converter

Fig. 11 shows the output voltage and current as the time in the load fluctuation condition. Output is 12 voltages stably regardless randomly changing load.

Fig. 12 shows the current graph as the time. It is the taking time to cut off power supply when the controller controls MOSFET, in case of over-current occurs due to load used over 24 watts power. It shows that the power is cut in 5 us after over standard current 2 amperes.

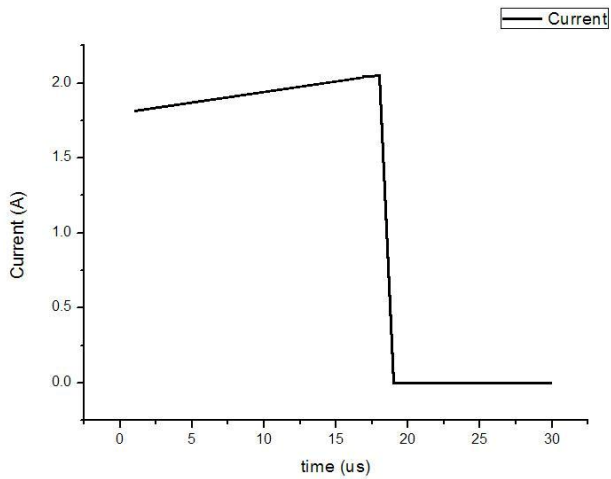

Fig. 12 Controlled Over-Current Condition

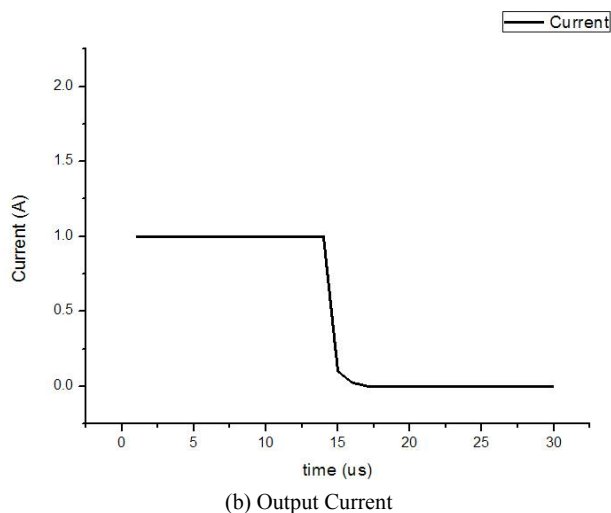
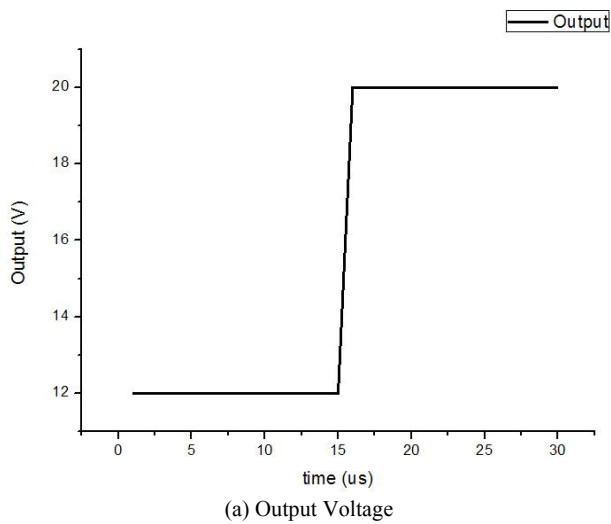

Fig. 13 Control of the Time Over-Current

Fig. 13 shows the voltage graph as the time. In case of

inverse voltage at the load, the processor controls MOSFET according to control equation. However if the voltage is unstable and exceeds the standard voltage value, the processor makes MOSFET-off in circuit. At this time, output voltage is overvoltage state but the input voltage keeps the voltage of fuel cell, so there is no current flow. Output current (b) shows that.

#### IV. CONCLUSIONS

These data are obtained through the DC-DC converter design and control experiment for fuel cell pack of the military application.

- 1) This paper presents dynamic characteristic analysis of the SEPIC converter and controller which is able to step-up and step-down.
- 2) Fuel cell protective function is realized using the controller without any additional circuit.

#### REFERENCES

- [1] Su-Jin Jang, Tae-Won Lee, Won-Chul Lee, Chung-Yuen Won, "Bi-directional DC-DC Converter for Fuel Cell Generation System", Power Electronics Specialists Conference, Germany, 2004, pp. 4722-4728.
- [2] Su-Hwan Baek, Seongyop Lim, Young-Chul Park, Doo-Hwan Jung, Sang-Kyung Kim, Mignon Park, Dong-Hyun Peck, "Performance and Operating Characteristics of a 20W Class DMFC Stack", 44<sup>th</sup> Power Sources Conference, Las Vegas, Nevada, June, 2010, pp. 223-226.
- [3] Wei Gu, Dongbing Zhang, "Designing a SEPIC Converter", Excellent Design Guidelines, National Semiconductor in Application Note, April, 2008, pp. 1-6.
- [4] Ray Ridley, "Analyzing the Sepsic Converter", Power Systems Design Europe, November, 2006, pp. 14-18.
- [5] "SEPIC Equations and Component Ratings", Maxim Integrated Products, April, 2002, Appnote 1051, 2005