

Design and Construction of Microcontroller-Based Telephone Exchange System

Aye Sandar Win

Abstract—This paper demonstrates design and construction of microcontroller-based telephone exchange system and the aims of this paper is to study telecommunication, connection with PIC16F877A and DTMF MT8870D. In microcontroller system, PIC 16F877 microcontroller is used to control the call processing. Dial tone, busy tone and ring tone are provided during call progress. Instead of using ready made tone generator IC, oscillator based tone generator is used. The results of this telephone exchange system are perfect for homes and small businesses needing the extensions. It requires the phone operation control system, the analog interface circuit and the switching circuit. This exchange design will contain eight channels.

It is the best low cost, good quality telephone exchange for today's telecommunication needs. It offers the features available in much more expensive PBX units without using high-priced phones. It is for long distance telephone services.

Keywords—Control software, DTMF receiver and decoder, hook sensing, microcontroller system, power supply, ring generator and oscillator based tone generator.

I. INTRODUCTION

ANY business cannot survive without the availability of a telephone. Communication is very important in today's business world. If the business is small, then a single telephone line may suffice. Nowadays, any business must have at least two lines, one for telephone calls and the other for use with a facsimile machine or personal computer. When more than two lines are needed, it needs to extension lines.

The systems for doing this are given the general name Call Routing Apparatus (CRA). The largest type CRA is a Private Branch Exchange (PBX). The earliest PBXs were manually switched Private Manual Branch Exchange (PMBX). The later PBXs were automatically switched (PABX) [1].

The first regular telephone exchange was established in New Haven in 1878. Early telephones were leased in pairs to subscribers. The subscriber was required to put up his own line to connect with another. In 1889, Almon B. Strowger a connect Kansas City undertaker invented a switch that could one line to any of 100 lines by using relays and sliders. This switch became known as "The Strowger Switch" and was still in use in some telephone offices well over 100 years later.

The author is with the Ministry of Science and Technology (corresponding author to provide phone: 033-315-08; fax: 033-315-53; e-mail: ayesandarwincht.1@gmail.com). She is now with the Material Science and Material Engineering Research Centre, Dattaw, Kyaukse, Myanmar.

Almon Strowger was issued a patent on March 11, 1891 for the first automatic telephone exchange.

The first exchange using the Strowger switch was opened in La Porte, Indiana in 1892 and initially subscribers had a button on their telephone to produce the required number of pulses by tapping. An associate of Strowgers' invented the rotary dial in 1896 which replaced the button. In 1943, Philadelphia was the last major area to give up dual service (rotary and button) [2].

Telephone exchange is a system that allows and controls the sharing of phone lines between telephones and other communication devices. It is widely used by office, hotel applications and the business organizations. A telephone exchange system is useful for a bank or brokerage house speech system or the like, which can accommodate a large number of lines. It features internal calls without getting changed, because calls are routed internally. It has connectivity to the telephone network in most cases. It provides more features than the telephone network provides.

The telephone exchange is also the private automated branch exchange. It is used on the subscriber's private premises. It provides a switching facility for telephone on extension lines within the building and across the PSTN. Today, almost all PBXs use digital technology to control microprocessor components as public exchanges progressed from using analog technology to digital. PABXs are available in size ranging from a few extensions and one exchange line up to several thousands of extensions and hundred of exchange lines [8].

A PABX is a telephone exchange that serves a particular business or office, as opposed to one a common carrier or Telephone Company operates for many businesses or for the general public [3].

Even with the recent birth of the World Wide Web and other new generation digital communication techniques the public switched telephony network is still one of the most important communication systems in the world.

The telephone exchange system is popular among organizations because of the communication freedom; it is capable of supplying its users with. Having a fast, efficient and user-friendly local phone network can often be a major requirement for a successful business organization. The popularity of the telephone exchange system can be seen by the extensive use of their applications around the globe. From this popularity the understanding of the fundamentals of an exchange system's operation and its popularity are the primary motivator for this paper.

A. Overview of the Microcontroller-Based Telephone Exchange System

This paper demonstrates the eight line telephone systems with full signaling and switching functions similar to those of the central office systems. The eight telephones are connected to the switching devices and common line. In microcontroller system, PIC16F877A microcontroller is utilized to control tone control, ring relay and on/off-hook switch when the telephone is used. Tone generator is used to get dial tone, busy tone, and ring tones. Ringing is generated at the receiving end of the phone being called. Ring relay is used to get tone and ring processes. DTMF is the basis for voice communication control. Each number consists of a combination of two frequencies. DTMF decoder converts the DTMF tones to the binary numbers and sends to the microcontroller.

In the signaling and switching system, transistors and relays are used to switch audio signals and control signals and to decode the DTMF signals. These switches are controlled by powerful software procedures to be implemented.

Battery feeds are 24V DC for telephone operation, 90V AC for ringing and 5V DC for microcontroller, DTMF receiver and decoder. DC power supplies are needed mainly to produce the large voltages required to power the phone during normal operation.

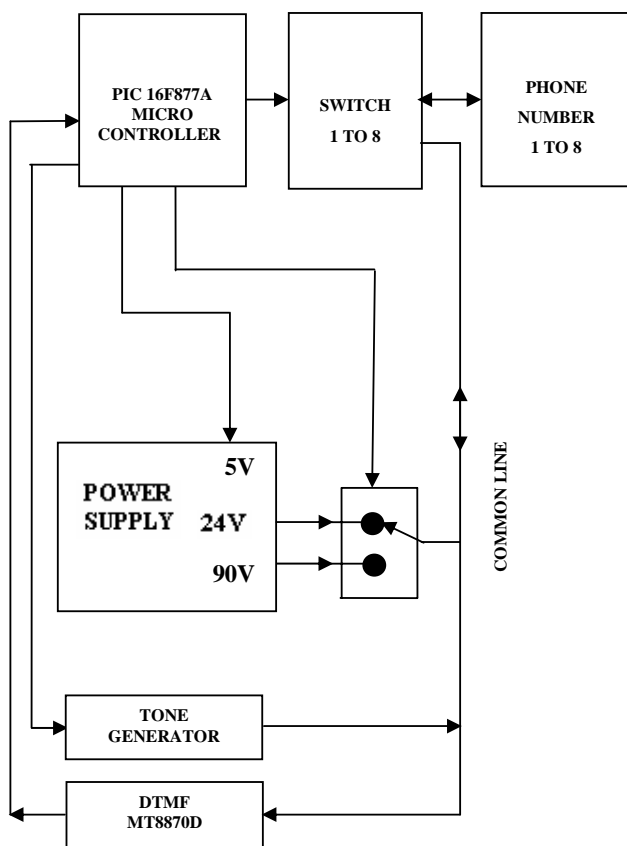

Fig. 1 Block Diagram of Microcontroller-Based Telephone Exchange

Most of the telephone exchange systems are implemented with phone line interface module design. In this paper, line driver and switching circuit will be used which has eight internal phone lines. The executed programs of this paper are the technical features, the hardware design and the control software of telephone exchange system.

II. BORSCHT FUNCTIONS

B: Battery - 48V central office battery supplies DC loop current (about 40 mA) to energize the voice transmitter and the outgoing signal circuit. The battery feed must provide the following for the local loop:

1. Power (typically 48V DC) to the subscriber's telephone set
2. The capability to allow signaling to and from the telephone set
3. Low DC resistance
4. High AC impedance

O: Overvoltage protection - Bypassing or fusing or a combination to prevent damage from lightning, power line induction, or accidental power line contact.

R: Ringing - Ringing is often provided by means of a dedicated ringing generator that is connected onto the loop by means of a relay. It is possible to generate ringing voltages at the line interface if the current generators have a high enough voltage source available to them. Or alternately, a switching converter with step up capability can be placed on the interface. Connection of the AC ringing signal to the loop for outgoing signaling (typically about 90V at 20Hz, interrupted for 4s of every 6s).

S: Supervision - Detection of loop current to signal demand for service (or off-book), termination of connection (or on-hook), and dial pulsing of routing codes for setting up the switches along the route (or detecting the same as outputs of a multi-frequency Touch Tone signaling unit).

C: Coding / Decoding - Provision of the PCM CODEC functions for connection to a digital switching system (only provided in recent digital switching machines).

H: Hybrid - Two-wire to four-wire conversion before connection to a digital switching machine (as for the CODEC function).

T: Testing - Provision to allow either automatic or manual testing of the subscriber's loop circuit from the central office [7], [9].

This system provides only the BORS functions from the list above. In this paper, 24V DC is used to communicate in the surroundings and the buildings, offices at most 500 yards because there is no purpose for long distance. Positive or negative battery can be chosen because 24V is grounded. It is compatible for large exchange by using negative battery.

Moreover, only one processor is used because it is enough for applications. In this circuit two transistors are used as astable flip flop. Oscillation frequency is used based on RC timing using charge and discharge.

It means that when a design is implemented, optimization is used depend on intension. There are some differences depend

on the countries which are manufactured the exchanges.

In this paper, 24V DC for telephone operation, 90V AC for ringing and 5V zener voltage regulator for microcontroller, DTMF, tone generator and switching devices. Surge arrestor is used for overvoltage protection. Ring relay is used for ringing. Opto-coupler is used for supervision. Surge arrestor or surge protector is an appliance designed to protect electrical devices from power surges and voltage spikes.

III. HARDWARE DESIGN OF MICROCONTROLLER-BASED TELEPHONE EXCHANGE

The microcontroller-based telephone exchange system is designed and built by both hardware and software controlled. In this system, the main control unit parts are involved as hardware implementation. The whole reading and controlling is done by PIC software.

The telephone exchange uses line driver and switching circuit such as transistors and relay. The eight telephones are connected to the collector of the transistors and common line. The LEDs are shown whether the telephone is on-hook or off-hook. The important portions of telephone exchange system are microcontroller and dual tone multifrequency. DTMF is the name for the standard touch-tone. It is the basis of voice communication control. Each number consists of a combination of two frequencies. DTMF decoder converts the DTMF tones to the binary numbers and sends to the microcontroller. Microcontroller knows which key is pressed. Opto-coupler is sensed for hook sensing. Tone generator is based on astable multivibrator. Ring relay is used for ringing.

A. Power Supply

In most power supply applications, the standard 60Hz AC power line voltage must be converted to a sufficiently constant DC voltage [6]. In Fig. 2, the output of a bridge rectifier must be filtered to reduce the large voltage variations. The capacitor filtered the output of the bridge rectifier. The filtering concept shows a nearly smooth DC output voltage from the filter. The small amount of fluctuation in the filter output voltage is called ripple.

In this paper, there are three kinds of power supply: 5V DC for microcontroller, DTMF and switching devices 24V for telephone operation and 90V for ringing.

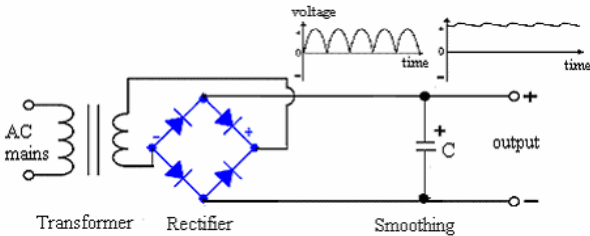

Fig. 2 Output Voltage of a Power Supply

B. Ripple Voltage

The capacitor quickly charges at the beginning of a cycle and slowly discharges after the positive peak (when the diode is reverse-biased). The variation in the output voltage due to the charging and discharging is called the ripple voltage [4].

C. Pi Low-Pass Filter

Low pass filters using LC components, i.e. inductors and capacitors are arranged in either a pi or T network. For the pi section filter, each section has one series component and either side a component to ground [5].

Transformer steps down high voltage AC mains to low voltage AC. Rectifier converts AC to DC, but the DC output is varying. DC is smoothed from varying greatly to a small ripple. Generally, ripple is undesirable; thus, the smaller the ripple, the better the filtering action. If the circuit connected to the power supply takes a lot of current, the capacitor will discharge more quickly and there will be a higher ripple voltage. The more frequent the voltage peaks from the rectifier, the more often the capacitor will be charged, and the lower the ripple voltage will be.

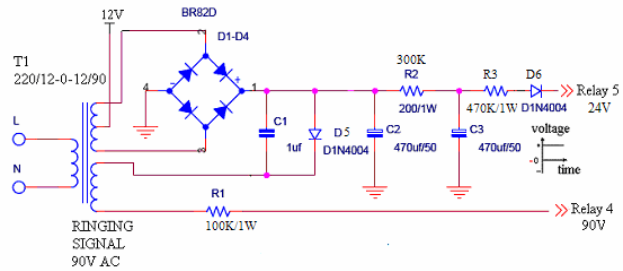

Fig. 3 Output Voltage of Pi Low-Pass Filter

If the ripple voltage is calculated, this formula can be used.

$$V_r = I_o / 2fC \tag{1}$$

where V_r is the ripple voltage in Volts, I is the current taken by the circuit in Amps, C is the value of the smoothing capacitor in Farads, and f is the frequency of the peaks from the full-wave rectifier, in Hertz. This frequency will be double the normal mains frequency, i.e. 100Hz in the case of the UK mains supply, or 120Hz in the case of the US mains supply.

Assume that $C = 4700\mu\text{F}$, $I = 20\text{mA}$

$$V_r = 20 \times 10^{-3} \text{A} / 2 \times 50 \times 4700 \times 10^{-6} = 42\text{mV (approximately 40mV)}$$

The ripple voltage should not be more than 10% of V_s - if it is, increase the value of the smoothing capacitor. The larger the capacitor value, the more charge it can store, and the slower it will discharge. Therefore, smoothing capacitors are normally electrolytic capacitors with values over $470\mu\text{F}$. $4700\mu\text{F}$ capacitor is the largest and 20mA is the smallest value. Even using these values noise are appeared. As it is

impossible to use more than 4700µF capacitor, pi low-pass filter is used in this circuit.

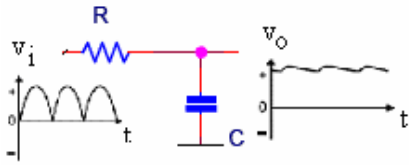

Fig. 4 RC Filter Circuit

$$v_o = v_i * \left[\frac{1}{R + j2\pi fC} \right]$$

$$= v_i * \left(\frac{1}{1 + j2\pi fCR} \right)$$

$$v_o = v_i * \left(\frac{1}{\sqrt{1 + (2\pi fCR)^2}} \right) \quad (2)$$

In this equation the more the frequency, the less the output voltage. DC current is needed but noise frequency is 100 Hz that is twice of the line frequency.

C₁ and D₅ are used because AC for ringing and DC for telephone operation are used together. When AC converts to DC, ripples are appeared. C₁ reduces the output ripples from the bridge rectifier and low pass filter reduces the output ripples again from C₁. This circuit is called pi-filter. R₃ (470Ω/1W) limits the current that draws the telephone. D₆ protects the circuit from the reverse current. In this paper, R₁, C₂ and C₃ act as a pi low-pass filter, to eliminate harmonics of the supply frequency.

D. 5V Zener Diode Regulator

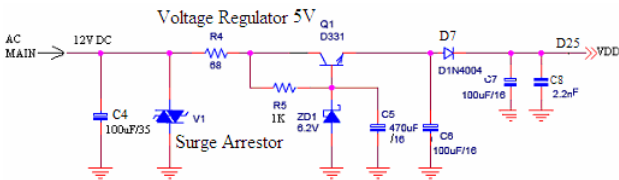

Fig. 5 5V Zener Diode Regulator

A regulator circuit can use to provide a DC voltage that not only has much less ripple voltage but also remains the same DC value even if the input DC voltage varies somewhat, or the load connected to the output DC voltage change. The large value of the capacitor is needed to filter the ripple voltage according to charging and discharging actions. The unregulated DC voltage is achieved from the capacitor filter which is regulated to have 5V DC voltage by using zener diode regulator. 24V DC and 90V AC are not regulated. Because the voltage must be stable for microcontroller. The supply voltage needs to be between 5.5V and 4.5V at most. The line voltage 220V AC is transformed to 12V. The step-down voltage is then applied to the bridge rectifier. In this

circuit, transformer center tap is kept 12V DC is got because of the bridge rectifier. 12V DC is reduced by using transistor Q1. Q1 acts as a voltage follower. Q1 base is stabilized by using 6.2V zener diode. Q1 emitter is 12-6.2 = 5.6V. Zener diode is used with a transistor because sufficient current is needed. If only zener diode is used, the current is not enough. C₅ and C₆ are reduced the output ripples from 12V. Diode D₇ protects the transistor from the reverse current that emerges from logic circuit. 0.6V is reduced and the output voltage is got 5V passing through diode D₇. 5V is supplied the microcontroller 16F877, DTMF MT8870D and switching devices. Using 5V zener diode regulator is cheap.

E. Powering the Telephone

Telephones require large DC voltages for standard operation. When a phone is in the on-hook state (receiver in cradle) the required voltage is 24V DC. This is said to be called the idle voltage. When the phone is in the off-hook state (receiver has been picked up) the required voltage is 12V DC.

When the phone is on-hook no DC current actually flows. This is because the only circuitry connected to the line is the ringer circuitry, which includes a capacitor. The capacitor will only allow AC signals to pass through such as the ringing signal.

When the phone becomes off-hook the resistance of the whole phone circuitry was found to be 600Ω. Once off-hook, DC current can now pass through the phone.

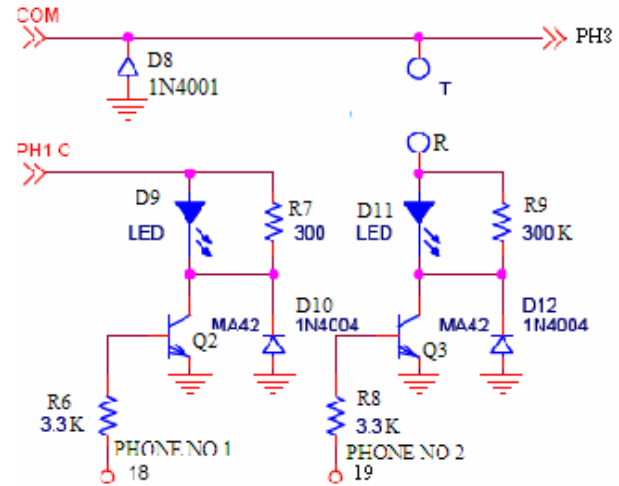

Fig. 6 Telephones and Switching Circuits

Each telephone is connected in series with the common line and the collector of the transistor. Microcontroller always scans which phone is off-hooked by giving high voltage to the transistors alternately. If one of the phones is off-hooked, the transistor associated with the off-hooked phone will turn on and the collector current flows through the phone line and the common line to the opto-coupler. The opto-coupler is used to detect hook sensing.

F. Design of On-Hook/Off-Hook Sensing

In controlling environment must always be aware of the current hook state of each telephone. Obviously the phone can either be in the on or off-hook state. In the hook sensing design, NEC 2403 opto-coupler is used to sense the line current. Opto-coupler is designed to provide complete electrical isolation between an input circuit and an output circuit.

The input circuit of an optical coupler is typically an LED, but the output circuit can take several forms, such as the photo transistor. When the input voltage forward-biases the LED, light transmitted to the photo transistor turns it on, producing current through the external load. When the phone becomes off-hook, current flows through the opto-coupler causing it to switch. The switching normally changes an external circuit so that the phone becoming off-hook can be reported to the microcontroller.

When the phone is on-hook, no current flows through the opto-coupler and phone circuitry because the capacitor within the phone's ringer circuitry blocks DC current. This means there is no connection in the switching circuitry and the value of the hook sensing pin is 5V. When the phone becomes off-hook current will now flow down through the opto-coupler and phone circuitry. The current through the opto-coupler causes it to switch. Therefore current now flows in the switching circuitry and the value of the hook sensing pin will 0V.

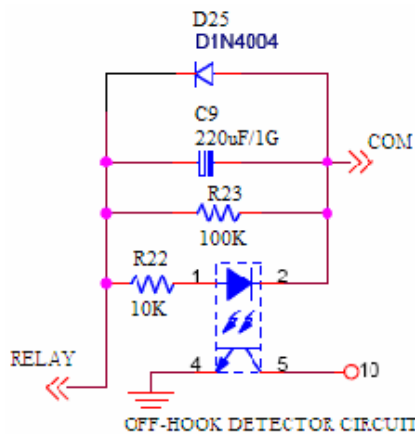

Fig. 7 Off-Hook Detector Circuit

The current is applied to the input of the opto-coupler, its LED lights, its light sensor then activates, its transistor is turn on and the output voltage is low. The output voltage goes to pin 10 (PORT RB1) in the microcontroller. Microcontroller always scans until PORT RB1 is low level. If PORT RB1 is low level, one of the phones will off-hook. Then microcontroller stops scanning and give high level to tone control pin 16 (PORT RB4). C₉ is used for not letting DC to pass through opto-coupler, R₂₃ is shut resistor and R₂₂ is used to limit the current passing through opto-coupler LED and one reverse connected diode in parallel with opto-coupler LED to prevent negative voltages from damaging the LED.

G. Tone Generator

The proper name for this circuit is "astable multivibrator". It is a simple, free - running oscillator circuit timed by the sizes of the resistors, capacitors, and power supply voltage. Unfortunately, its output waveform is much distorted. For the simple purpose of making an audio tone, however, distortion doesn't matter much. With a 5V supply and 22nF capacitors, the oscillation frequency will be in the low audio range. This signal is amplified by the amplifier. The multivibrator itself is just two transistors, two resistors, and two cross-connecting capacitors.

When pin 16 is high, two transistors Q₁₁ and Q₁₂ get supply voltage. Two transistors are used as astable flip flop. Two capacitors C₁₇ and C₁₈ are feedback each other. So two transistors turn on alternately. Oscillation frequency is got based on RC timing due to the charging and discharging. The output frequency is amplified by amplifier. R₅₀ and Q₁₀ (MA42) act as an amplifier. The amplified frequency is produced via tone line through relay to the common line. Then the auto dialing tone is heard in off-hooked phone and key is pressed.

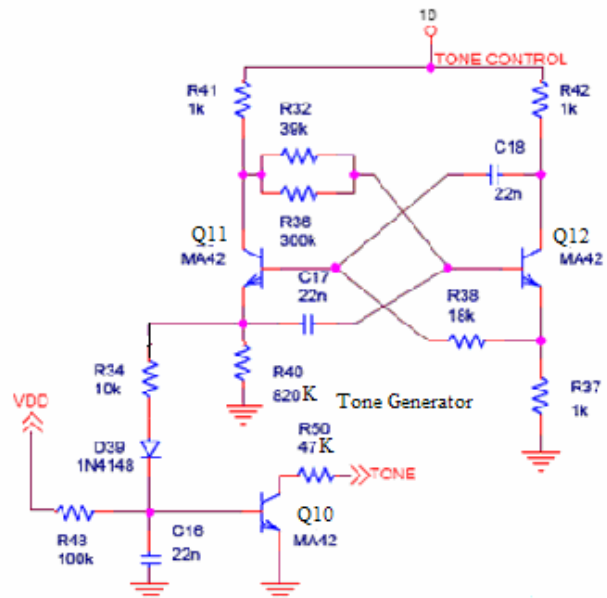

Fig. 8 Astable Multivibrator Tone Generator

H. Ring Generation

A ring generation system needs to be present on telephone exchange. Ring relay is connected to the tone line and ring line. More commonly the ring signal is at about 25 Hz and around 90 V. This AC ring signal is then superimposed onto the 24V DC required when the phone is in the on-hook state. The ring signal circuitry has been designed a technique needs to be implemented so that the ring signal can be cadenced. The technique used to achieve this based around one relay. The relay controls when the ring signal is cadenced, by connecting 24V DC for tone and 90V AC for ringing.

I. Generation of Progress Tones

A Telephony network needs a system whereby users can be informed of the current state of their telephone. Signals such as dial tones, ring tones and busy tones do just this. Without these signals the user can be left wondering if the network is even responding to their requests.

J. DTMF Detection

DTMF deals with interpreting which buttons on the telephone the user presses. When a button is pressed on a phone, a signal representing that button can be transmitted. This design will be based around only interpreting DTMF tones. The telephone exchange system needs is a DTMF detection system.

The circuit connects to the phone's audio line via a capacitor, which is used to block any DC current from going to the DTMF receiver IC. The DTMF tone was received. The circuit when tested was able to detect all DTMF tones and handle a tone separation as small as 90 ms.

When a button is pressed on a phone, key frequency passes through C₁₀ and R₂₄ to DTMF. The input tone signal is decoded by the DTMF decoder and the decoded number can be read by the PIC at D0-D3 output pins. There is no tone signal, the output is '0'. If key '1' is pressed, the output is '0001'. PIC microcontroller knows which number is pressed by scanning the output from DTMF decoder.

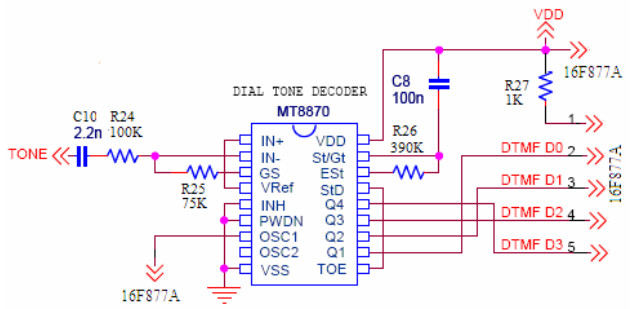

Fig. 9 Connection between Microcontroller System and DTMF

K. The Microcontroller

Pin diagram of microcontroller system is as shown in Figure 10. The PIC16F877 microcontroller is used to control the overhaul system. Oscillator can be 4M Hz crystal and either two 15pF capacitors or the ceramic resonator of the same frequency (ceramic resonator already contains the mentioned capacitors, but unlike oscillator has three termination instead of only two). The rate, at which the program runs, depends heavily on the oscillator frequency. The 4MHz crystal and capacitors connected to Pins 13 and 14 of the 16F877A produce the clock pulses that are required to step the microcontroller through the program and provide the timing pulses. The most common power supply connecting for the controller is 5V zener diode voltage regulator.

PORTA is configured to interface with DTMF receiver. The incoming frequencies are decoded by DTMF and appear at

RA0:RA3. The microcontroller needs to send DTMF tones to the telephone line. RA0:RA3 read or write binary number while decoding tones. RB1 bit is configured as input pin from on-hook and off-hook the phone line. The microcontroller uses RB0 bit to scan 25HZ ringing signal. RB2 is used to control the ring relay. The common line of relay contacts relay pin 4, ring tone can be heard. RB4 is utilized to control the tone generator. PORT C is just used to know which phone is using with LED signals. PORT D is used to sense the eight phones.

IV. SOFTWARE OF THE SYSTEM

The firmware program for the microcontroller is compiled with the CCSC Compiler Tool suite version 8.02 from HI-TECH Software. The source code is written in the MPLAB IDE version 7.5 from Microchip Corporation.

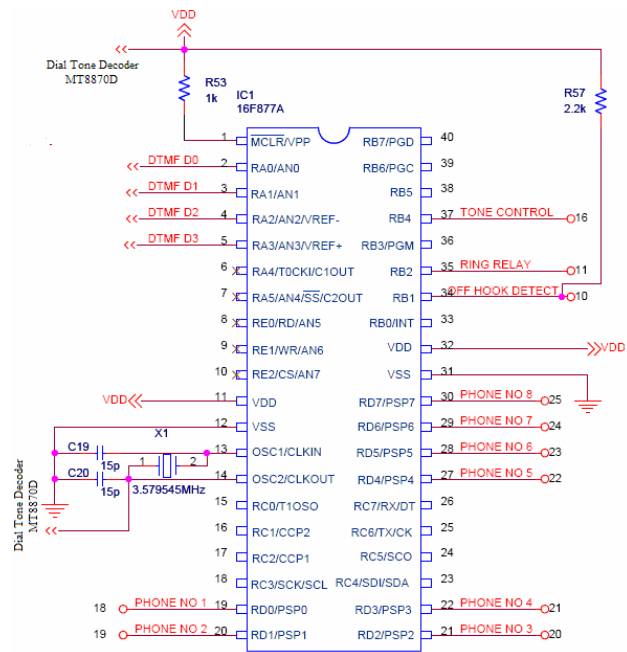

Fig. 10 Pin Diagram of Microcontroller System

The operation of the phone is broken down into seven states based around what part of the communication process the phone is currently in. A particular state is the "Off Hook – Dial" state. This state requires the audio circuitry to be switched to the phone and a dial tone to be generated. If a phone needs to be put into this state, the microcontroller knows signaling it to fulfill these requirements. Table I below lists all telephone states and describes what the requirements are for each.

The state chart allows the user to see which states the user can move to from a particular state. It is track the operation of the telephone exchange by seeing Fig. 11.

V. IMPLEMENTATION OF STATE CONTROL SYSTEM

Firstly, when the telephone is off-hook, a signal is sent to the microcontroller which the microcontroller understands to receive the phone number and the first digit is dialed. The first digit is internal code (*). When the code is dialed, the microcontroller knows whether the code is correct or wrong. It begins the routing process. If internal key (*) is received, the number the user want to call is entered. When the number is correct, the call progress starts. If there is invalid code or invalid phone number or idle called phone or self call, busy tone will be heard. In call progress state, there are four sub states: tone wait, tone generate, ring wait and ring generate. If the called phone is off-hook, success state begins. If the caller phone is on-hook in any state, the state must be idled and if the time is out, the busy tone will be heard.

TABLE I
PHONE STATE REQUIREMENTS

State	Phone Connection	Ring Generated	Tone Generation
On Hook	Ring Circuitry	No	No Tone
On Hook - Ringing	Ring Circuitry	Yes	No Tone
Off Hook	Audio Circuitry	No	No Tone
Off Hook-Dial	Audio Circuitry	No	Dial Tone
Off Hook-Busy	Audio Circuitry	No	Busy Tone
Off Hook-Ring	Audio Circuitry	No	Ring Tone
Off Hook-Connect	Audio Circuitry	No	No Tone

VI. CONCLUSION

The design concept for the microcontroller-based telephone exchange system has been defined.

The telephone exchange system demonstrates call switching concepts. In this paper, 220V transformer steps down to 90V, 50Hz. It is not a standard design but useful. 24V DC is employed for telephone operation because telephone exchanges are used only for the surroundings, buildings and offices within 500 yards and 24V DC is for low power consumption. But 48V DC can be used for long distance. 5V zener diode voltage regulator is applied because it is enough to operate and the required current is not more than 1A.

Instead of using ready made tone generator IC, oscillator based tone generator is used. Hence, there is no need to spend the foreign exchange. Continuous tone is dial tone, discrete tone (2 second on/off alternatively) is call progress tone or ring tone and fast tone (0.5 second on/ off alternatively) is busy tone. If tone generator IC can easily be got, there will be more functions to operate. Although only human can understand these tones, it is not convenient for the machine.

Only one processor is used for all functions because there is no much function. Hybrid is not used but common line and ground line are employed because there is no switch matrix. This circuit is a kind of non-extensible exchange that is compact and low cost. A pair of telephones is used at the same

time because only one common line is used. If two pairs are used, two common lines must be used.

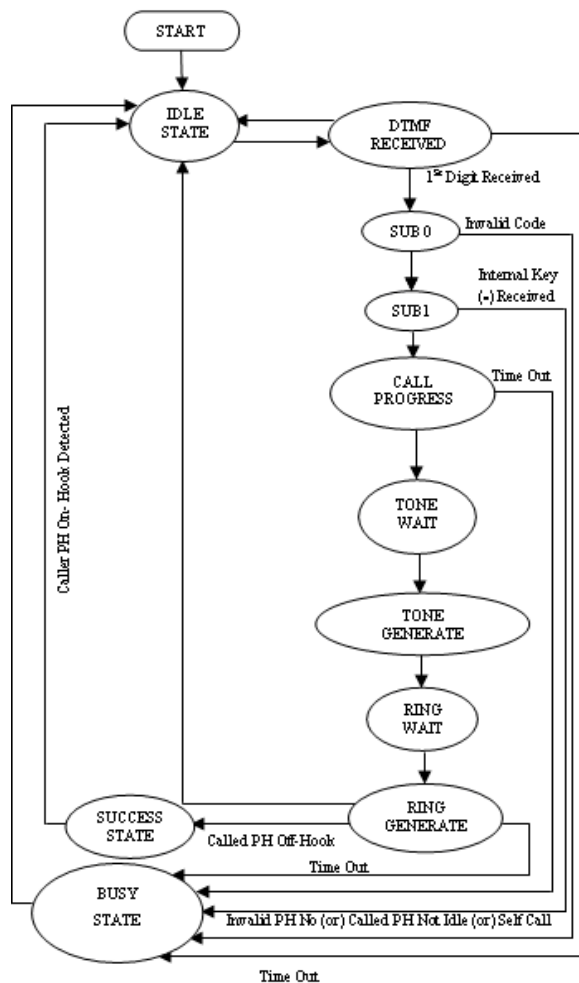

Fig. 11 State Chart of the Control Program

ACKNOWLEDGEMENT

We would like to thank U Kyaw Zwa Soe, U Aung Aung Thein and Dr. Win Aye for their comments on the early drafts of this paper. We would also like to thank the referees for their help in improving the clarity of the presentation.

REFERENCES

- [1] <http://www.innovexpo.itee.uq.edu.au/2001/projects/s369342/poster.pdf>
- [2] http://www.nps.gov/nhl/DOE_dedesignations/Telephone.htm
- [3] http://en.wikipedia.org/wiki/Private_branch_exchange#PBX_functions
- [4] <http://www.mitedu.freemove.co.uk/Design/dcpsu.htm>
- [5] http://www.radio-electronics.com/info/circuits/lc_lowpassfilter/lc_lpf.php
- [6] <http://en.wikipedia.org/wiki/powersupply>
- [7] http://en.wikibooks.org/wiki/Communication_Systems/Telephone_System
- [8] R.Blake. "The Telephone System. *Comprehensive Electronic Communication*", 1997, pp. 325-344.
- [9] S.J.Bigelow, J.J. Carr, S.Winder, "Understanding Telephone Electronics," Fourth Edition, Butterworth-Heinemann, 2001.