

Delay and Packet Loss Analysis for Handovers between MANETs and NEMO Networks

Jirawat Thaenthong and Steven Gordon

Abstract—MANEMO is the integration of Network Mobility (NEMO) and Mobile Ad Hoc Network (MANET). A MANEMO node has an interface to both a MANET and NEMO network, and therefore should choose the optimal interface for packet delivery, however such a handover between interfaces will introduce packet loss. We define the steps necessary for a MANEMO handover, using Mobile IP and NEMO to signal the new binding to the relevant Home Agent(s). The handover steps aim to minimize the packet loss by avoiding waiting for Duplicate Address Detection and Neighbour Unreachability Detection. We present expressions for handover delay and packet loss, and then use numerical examples to evaluate a MANEMO handover. The analysis shows how the packet loss depends on level of nesting within NEMO, the delay between Home Agents and the load on the MANET, and hence can be used to developing optimal MANEMO handover algorithms.

Keywords—IP mobility, handover, MANET, network mobility

I. INTRODUCTION

MANEMO [1], [2] refers to a network that integrates a Mobile Ad Hoc Network (MANET) and with a mobile network using the IETF Network Mobility (NEMO) protocol. In other words, a Mobile Node (MN) can potentially access Internet hosts via the MANET and/or via NEMO. Such a case may occur in scenarios that utilize vehicular networking, personal/body area networks, and emergency services and military networks. If a mobile node has access to two or more different networks, it is important for that node to be able to choose the *best* network, and possibly utilize both networks.

NEMO Basic Support Protocol [3] is an extension of Mobile IPv6 [4] to support network mobility. It allows entire networks, consisting of a Mobile Router (MR) and its attached hosts, to change IP networks (similar to how Mobile IPv6 allows a mobile node to change IP networks). While visiting foreign networks the MR maintains a bi-directional tunnel to its Home Agent (HA). When a MR attaches to another MR the case of Nested NEMO arises.

NEMO is especially suitable for vehicular communications where a MR on-board a vehicle provides network access to other devices in the vehicle. A major issue with NEMO is the overhead/extra delay of routing via potentially several HAs when nesting is present. To overcome this problem there are several proposals for route optimization in NEMO, including utilizing MANEMO (see [5]).

A MANET is an unstructured network formed dynamically among a set of mobile nodes. Nodes within a MANET may

access the Internet via a MANET Gateway. There are several methods for MANET/Internet integration [6]—in this paper we assume Mobile IPv6 is used to allow packets to be delivered from the Internet to a MANET node.

In a truly heterogeneous network there will be cases where a MN has access to the Internet¹ via both NEMO and a MANET. For example, a MN or MR on board a vehicle using NEMO also has a MANET routing protocol and Internet connectivity via a MANET Gateway. There are several issues being researched for such a MANEMO node. For example, techniques for discovering the MANET gateway, criteria and algorithms for selecting the MANET or NEMO interface, especially for route optimization [7], [8], and using MANETs as a backup in event of NEMO infrastructure failure [9]. As far as we are aware, optimal handover procedures and algorithms are yet to be defined for MANEMO.

In this paper we define the handover procedure between MANET/NEMO, and characterise the costs in terms of delay, packet loss and network overhead that occurs for a handover. This is a step towards defining handover algorithms for MANEMO, as well as utilizing multihoming in MANEMO.

In Sec. II we explain the concept of handover in MANEMO, and then in Sec. III describe the MANEMO scenario under consideration. In Sec. IV we define the protocol operations for completing a MANEMO handover, as well as calculate the handover time. Sec. V gives numerical results for handover delay and packet loss, while Sec. VI concludes the paper.

II. MANEMO HANDOVERS

Handover procedures can be classified as either layer 2 (e.g. between IEEE 802.11 APs) or layer 3 (e.g. using Mobile IP). In this paper we focus on L3 handover, in particular when a mobile node or router can attach to two different IP networks, one via NEMO and the other via a MANET.

A. Handover in NEMO

NEMO allows an entire IP network (mobile router and its members) to perform a L3 handover. When a Mobile Router loses access to its old access router, or decides to connect to a new access router, NEMO will perform a Binding Update with the MR's HA, informing the HA of its Mobile Network Prefix and establishing a bi-directional tunnel. During the NEMO handover, nodes within the mobile network cannot communication with correspondent nodes (CNs).

¹In this paper when referring to "the Internet" we mean IP hosts outside the MANET and NEMO networks

J. Thaenthong and S. Gordon are with Sirindhorn International Institute of Technology, Thammasat University, Pathumthani 12000, Thailand (phone: +66-2-501-3505; fax: +66-2-501-3524; email: jirawat@ict.siit.tu.ac.th; steve@siit.tu.ac.th)

B. Handover in MANETs

Consider a MANET connected to the Internet via a MANET Gateway. One approach to allow a MANET node to communicate with hosts on the Internet is to use Mobile IP. The MANET Gateway is an IP access router. When a MANET node wants to communicate with an external host, it must discover the gateway, obtain an IP prefix and sending a Binding Update to its HA. The communications between MANET node and gateway is dependent on the MANET routing technology. Essentially the MANET is treated as a link by IP/Mobile IP. With this model of MANET/Internet connectivity, a L3 handover in a MANET occurs when a mobile node (with MANET functionality) changes access routers (where at least one is the MANET Gateway).

C. Handover in MANEMO

In MANEMO, we consider a handover as a MN changing access to the Internet from via a MANET Gateway to via a fixed access router (and vice versa). When the MN is using the fixed access router, we assume NEMO is utilized, and hence will refer to the access router as a *NEMO Gateway*. Although the MANEMO node may have only one physical interface, it may use virtual interfaces and we can refer to the MANET interface and NEMO interface. A MANEMO handover is changing the interface used for packet delivery to/from the CN. The handover procedures on both networks are explained in Sec. IV. In this paper, we assume the a handover algorithm exists so the MANEMO node knows when to initiate a handover.

III. MANEMO SCENARIO AND ASSUMPTIONS

A. MANEMO Scenario Description

We assume there is a MANET connected to the Internet via a gateway, as well as a nested NEMO network (i.e. multiple mobile routers) as illustrated in Fig. 1. At least one node has access to both networks. That is, the MANEMO node runs a MANET routing protocol to connect to the MANET, as well as capabilities to connect to the nested NEMO network.

This scenario may depict a vehicular communications network where there are a number of vehicles equipped with on-board IP nodes, as well as passengers with personal devices. In a heterogeneous network it is unlikely all nodes will support the same capabilities. For example, some vehicles may act as MRs, others may only support a particular MANET routing protocol, while some may be able to connect to either a MANET or NEMO network. The MANEMO node can communicate with other nodes in the MANET/NEMO or with a CN in the Internet.

There are four types of NEMO nodes. The handover procedure depends on the role of the MANEMO node in NEMO.

A *Local Fixed Node* (LFN) is permanently attached to a Mobile Router. By definition, a LFN does not run Mobile IP and will always use the MR. Although at L2 it could connect to the MANET, it cannot perform a L3 handover via the MANET Gateway. Therefore in this paper we ignore the case of a MANEMO node being a LFN.

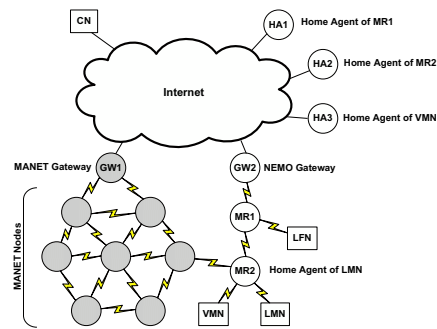

Fig. 1. The scenario of MANEMO handover in Vehicle Network

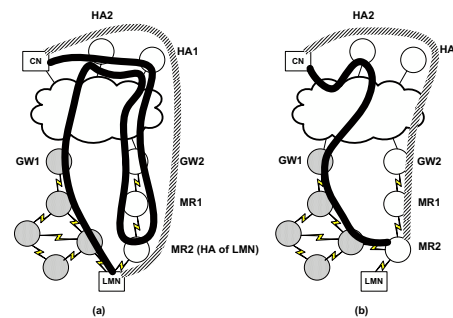

Fig. 2. Packet delivery for different node types: (a) LMN; (b) MR

A *Local Mobile Node* (LMN) is a mobile node currently in its home mobile network. Normally, a LMN runs Mobile IP, allowing it to move to other networks. While in the home network, although a LMN may be able to connect to a MANET, in most cases it will be inefficient to have packets delivered via the MANET Gateway (rather than the NEMO MR). Consider Fig. 2(a). As a LMN is in its home network, the path used via NEMO is optimal. If a LMN was to handover to the MANET, packets must be sent through a bi-directional tunnel from the LMN to MANET Gateway to the MR (the LMN's HA) and then to the CN [5]. In most cases² if the LMN has a choice between routing via the NEMO or MANET, the NEMO will be chosen. For brevity, we do not consider the case of a MANEMO being a LMN in this paper.

A *Visiting Mobile Node* (VMN) is a mobile node currently in a foreign mobile network. Unlike a LMN, it may be beneficial for a VMN to route packets via the MANET Gateway, rather than the NEMO network. For the case of a nested NEMO, doing so may avoid sub-optimal routing via multiple HAs. In Fig. 1 if using the NEMO interface packets are routed via HA1 and HA2; while using the MANET interface packets are routed only via HA3.

A *Mobile Router* (MR) is a router capable of changing its point of attachment to the Internet, moving from one link to another link. The hosts attached to a mobile router can be LFN, LMN or VMN. As with the VMN, if the MR's HA is outside the NEMO network, then packets routed via the

²An exception may be if the CN is in the MANET, however in this paper it is assumed the CN is in the Internet.

MANET traverse a single HA, whereas via NEMO traverse a HA for each level of nesting (see Fig 2(b)).

If the MANEMO node is a VMN or MR, then the handover procedures are similar. For this paper we consider the case of a MR—the case for a VMN can easily be extended from this. The handover procedure for a MR is defined in Sec. IV.

B. Assumptions

In the remainder we assume a CN is an IPv6 host in the external network (Internet), not within the MANET or NEMO network. NEMO Basic Support Protocol is used (no route optimization), meaning all packets from MANEMO to CN must traverse relevant HAs.

The MANET is formed using AODV, and the MANET Gateway can advertise its network prefix periodically based on [10]. Stateless Address Autoconfiguration is used, and nodes can use the advertised prefix with their MAC address to define a unique Link Local address. All MAC addresses are unique.

All wireless interfaces use IEEE 802.11g. A MANEMO node has only a single IEEE 802.11g physical interface, however using virtual interfaces, we assume it may receive broadcast/multicast packets from multiple nodes on different subnets (e.g. NEMO MR and MANET neighbours). Although not normal operation of IEEE 802.11 devices, the virtual interface capability is supported in some operating systems (e.g. virtual stations in Linux 2.6.30). As the interface needs to be associated with either NEMO or MANET, the MANEMO cannot transmit on both interfaces at the same time.

IV. MANEMO HANDOVER PROCEDURE

Assuming the MANEMO is a MR, in this section we define the steps involved in the handover procedure when changing between MANET and NEMO networks. We also define the time necessary for each step.

A. Information Gathered Prior to Handover

A handover is initiated when the MANEMO node determines that using the alternate (new) interface will be better than using the current (old) interface. No matter the handover algorithm used, it is likely that the MANEMO node will gather information about both networks prior to a handover decision. This is possible because while using one interface, the MANEMO can still receive broadcast/multicast packets from the alternative interface.

While using the MANET interface a MANEMO node can also receive Route Advertisements (RAs) from NEMO MR's or the NEMO Gateway. From these Route Advertisements (and the included network prefix) the MANEMO node can immediately define a link-local address (using its own MAC address) and global CoA (using the network prefix and MAC address) once choosing to handover to the NEMO interface.

While using the NEMO interface a MANEMO node can receive routing messages (e.g. AODV Route Requests/Replies) as well as RAs from the MANET Gateway. This allows the MANEMO node to define link-local/CoA addresses, as well as obtain statistics on the number of neighbors and hops to the gateway.

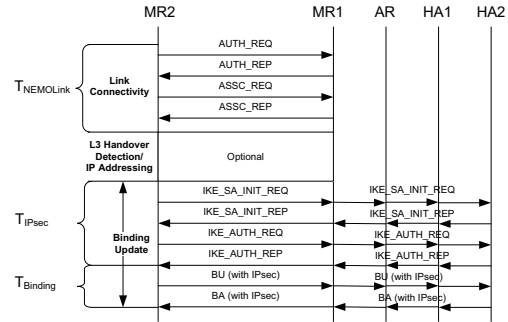

Fig. 3. Time sequence diagram for MR handover from MANET to NEMO

In both handover cases, by using the MAC address in the creation of link-local/CoA addresses, the MANEMO node can avoid time consuming Duplicate Address Detection [11], and immediately have the IP addresses once a handover decision is made. Hence there is no delay in IP address assignment.

B. Handover from MANET to NEMO

The handover procedure for a MANEMO node changing from a MANET interface to NEMO interface is illustrated in Fig. 3.

1) *Link Connectivity to AP:* The MANEMO node must establish L2 connectivity with a router in the NEMO network (either fixed access router or NEMO MR if nesting is present). As the MANEMO has already determined the routers address (Sec. IV-A) the IEEE 802.11 authentication and association procedure can begin immediately after a handover decision is made. Assuming negligible processing delays, the time for establishing link connectivity, $T_{NEMOLink}$, is given by (1):

$$T_{NEMOLink} = T_{WlanAssocReq} + T_{WlanAssocRep} + T_{WlanAuthReq} + T_{WlanAuthRep} \quad (1)$$

The time to deliver each message depends on various factors including message size, number of competing wireless nodes (which affects backoff times and collisions) and queue sizes. As all messages are small (ranging from 32 to 143 bytes), the second two factors will have most significant impact on delay. Therefore we assume all messages have identical size and the time to deliver one message over a single wireless hop is $T_{HopDelay}$. In Sec. V we discuss further appropriate values for $T_{HopDelay}$. Equation (1) can be simplified as:

$$T_{NEMOLink} = 4 * T_{HopDelay} \quad (2)$$

2) *L3 Handover Detection:* Neighbour Unreachability Detection (NUD) can be used by a NEMO node to discover if the MANEMO node has changed subnet. However, as shown in Sec. IV-A the MANEMO node has already learned about the new subnet, so it can bypass NUD.

3) *Binding Update:* The MANEMO node must perform a binding update to inform its HA of its new network prefix. IPsec for security is mandatory for the binding update. Therefore, the steps for the binding update are:

- The IPsec security association is established between MANEMO and HA using the Initialization Request/Reply messages.
- IPsec Authentication Request/Reply performed.
- Assuming authentication is successful, the MANEMO node sends a Binding Update to the HA, which responds with a Binding Acknowledgment.

All of the above messages must be sent over two segments: a multi-hop wireless network between MANEMO node and NEMO Gateway; and from the NEMO Gateway to necessary HAs. The delay incurred across each segment differs significantly. In the multi-hop wireless network the number of hops and network load, and hence level of contention, strongly influences delay. As with Sec. IV-B1 we assume the delay for sending any message over one hop is $T_{HopDelay}$. The delay from Gateway to HA (and possibly HA to HA) depends on the location of the HA and the backbone network technologies used. Again assuming the message size has minimal impact on delay, we characterize the time to send from gateway to first HA as T_{GWHA} , and between HAs as T_{HAHA} . Values for these times are discussed in Sec. V.

The time for the IPsec association and authentication is:

$$\begin{aligned} T_{IPsec} &= T_{IPsecAssocReq} + T_{IPsecAssocRep} + \\ &T_{IPsecAuthReq} + T_{IPsecAuthRep} \\ &= 4 * (L_{NEMO} * T_{HopDelay} + T_{GWHA} + \\ &(L_{NEMO} - 1) * T_{HAHA}) \end{aligned} \quad (3)$$

where L_{NEMO} is the levels of NEMO networks (including MANEMO node's network). The time for the Binding Update:

$$\begin{aligned} T_{Binding} &= T_{BU} + T_{BA} \\ &= 2 * (L_{NEMO} * T_{HopDelay} + T_{GWHA} + \\ &(L_{NEMO} - 1) * T_{HAHA}) \end{aligned} \quad (4)$$

4) *Total Time for Handover to NEMO*: The total time for a MANEMO handover from MANET to NEMO is:

$$T_{HOtoNEMO} = T_{NEMOLink} + T_{IPsec} + T_{Binding} \quad (5)$$

C. Handover from NEMO to MANET

The handover procedure for a MANEMO node changing from a NEMO interface to MANET interface is illustrated in Fig. 4. In the MANET, there is no layer 2 connectivity to be established as IEEE 802.11 adhoc mode is used. Also, as discussed in Sec. IV-A, the MANEMO node can bypass the process of L3 handover detection and IP addressing.

1) *Gateway Discovery*: Once the MANEMO node is part of the MANET (and is using an IP address recognised in the MANET), the node must discover a route to the CN. Using the MANET/Internet integration, the MANEMO node broadcasts a AODV Route Request. As the gateway is aware of all nodes in the MANET, it recognizes the MANEMO node is searching for a node (the CN) outside of the MANET, and immediately responds with a AODV Route Reply advertising a route to the CN. The time for discovering the gateway is:

$$\begin{aligned} T_{GWDisc} &= T_{AODVRReq} + T_{AODVRRrep} \\ &= 2 * H_{MANET} * T_{HopDelay} \end{aligned} \quad (6)$$

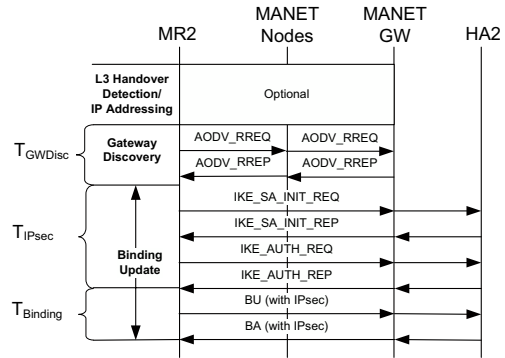

Fig. 4. Time sequence diagram for MR handover from NEMO to MANET

where H_{MANET} is the number of hops from the MANEMO node to MANET Gateway.

2) *Binding Update*: The MANEMO node performs a binding update using the same approach as in Sec. IV-B3:

$$\begin{aligned} T_{IPsec} &= T_{IPsecAssocReq} + T_{IPsecAssocRep} + \\ &T_{IPsecAuthReq} + T_{IPsecAuthRep} \\ &= 4 * (H_{MANET} * T_{HopDelay} + T_{GWHA}) \end{aligned} \quad (7)$$

$$\begin{aligned} T_{Binding} &= T_{BU} + T_{BA} \\ &= 2 * (H_{MANET} * T_{HopDelay} + \\ &T_{GWHA}) \end{aligned} \quad (8)$$

3) *Total Time for Handover to MANET*: The total time for a MANEMO handover from NEMO to MANET is:

$$T_{HOtoMANET} = T_{GWDisc} + T_{IPsec} + T_{Binding} \quad (9)$$

V. DELAY AND PACKET LOSS ANALYSIS

Any handover should aim to minimize the handover delay, as packets lost during handover will affect end-user applications. In addition, handover signalling should be minimised to avoid affecting other traffic (especially in the wireless segments). Assuming a VoIP call between CN and host attached to MANEMO node, the packet loss gives an indication of the effect of handover on the application. Packet loss from CN (i.e. downlink) consists of: at the time handover is initiated, all packets already sent by the MANEMO nodes HA; plus all packets sent by the CN up until the MANEMO nodes HA receives a Binding Update (there is no need to wait for the Binding Ack). With a sending packet rate of P_{rate} :

$$\begin{aligned} PL_{NEMO,DL} &= P_{rate} * (T_{HOtoNEMO} - T_{BA}) + \\ &P_{rate} * (T_{GWHA} + T_{HopDelay} * \\ &H_{MANET}) \end{aligned} \quad (10)$$

$$\begin{aligned} PL_{MANET,DL} &= P_{rate} * (T_{HOtoMANET} - T_{BA}) + \\ &P_{rate} * (L_{NEMO} * T_{HopDelay} + \\ &T_{GWHA} + T_{HAHA} * (L_{NEMO} - 1)) \end{aligned} \quad (11)$$

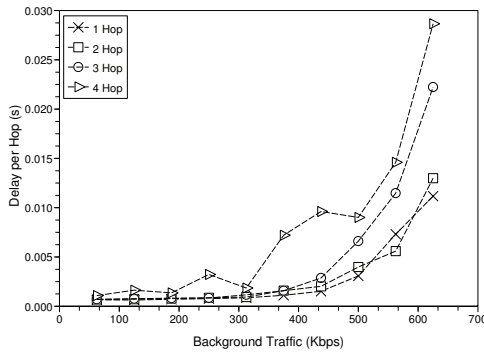

Fig. 5. Hop Delay vs Background Traffic vs Hop to NEMO/MANET GW

For packets sent to CN (uplink), the packet loss can be determined to be:

$$PL_{NEMO,UL} = P_{rate} * T_{HOtoNEMO} \quad (12)$$

$$PL_{MANET,UL} = P_{rate} * T_{HOtoMANET} \quad (13)$$

In order to evaluate the impacts of MANEMO handovers, in Sec. V-A we determine appropriate values for per-hop delay in a multi-hop wireless network. Then in Sec. V-B, V-C and V-D we calculate signalling load, handover delay and packet loss.

A. Message Delay Assumptions

As shown in Sec. IV the handover delay in MANEMO depends on the time to send messages over a multi-hop wireless network, plus across the Internet to HAs (T_{GWHA} and T_{HAHA}). Note that a nested NEMO network is essentially a multi-hop wireless network. To approximate the delay in a multi-hop wireless network, we use the NS2 simulator to obtain samples of $T_{HopDelay}$ for various number of hops and background traffic. An AODV MANET is established with 20 mobile nodes in an area of 600x600m. These nodes move according to random waypoint mobility model at 5m/s, and generate background traffic ranging from a total of 62.5kb/s to 625kb/s for a duration of 240 seconds. At the top edge is a fixed AODV node (i.e. MANET Gateway or NEMO access router), and an additional mobile node (MANEMO) moves toward and away from the fixed node. The simulation measures the average single hop delay experienced by the MANEMO node. A selection of the measured values for $T_{HopDelay}$ are shown in Fig. 5. Results are average over 10 simulation runs. For the delay across the Internet (i.e. T_{GWHA} and T_{HAHA}) we consider a range of values: 10ms to 80ms. This range is based on measured data from [12] for North America backbone networks in June 2009.

B. Signalling Overhead for MANEMO Handovers

Considering the default packet sizes for all steps in Sec. IV, the signalling overhead for a handover from NEMO to MANET is 918 Bytes, and 1040 Bytes for MANET to NEMO. These are both small, meaning the handover signalling will

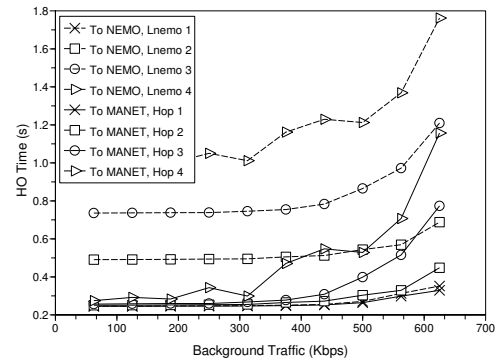
Fig. 6. Handover Time with T_{GWHA} and T_{HAHA} of 40 ms

have little or no effect on other users in the NEMO/MANET, even if multiple MANEMO nodes initiate a handover at the same time.

C. MANEMO Handover Delay

Fig. 6 shows the handover delay as the background traffic increases, for different levels of NEMO networks (L_{NEMO}) and different path lengths in the MANET (H_{MANET}). We consider only values of 1 to 4 for each, i.e. a maximum of 3 nested MRs, and a maximum of 4 hops from MANEMO to MANET Gateway. In all cases, T_{GWHA}/T_{HAHA} are 40 ms.

The first observation is that when handing over to NEMO when nesting is used ($L_{NEMO} > 1$), the delay is higher than to MANET. This is important for the design of MANEMO handover algorithms: in order for a handover algorithm to make a decision to change from MANET to NEMO, the level of nested MRs in NEMO should be known. If not, a handover to NEMO may result in unacceptable packet loss for the user.

The second observation is that when the background traffic is above 500kb/s, the wireless hop delay and hence handover delay will rise exponentially. Therefore it is advisable if a MANEMO handover algorithm can estimate the load in MANET or NEMO before making a handover decision.

D. Packet Loss for MANEMO Handovers

The packet loss in the uplink direction (towards CN) given by 12 and 13 is directly proportional to the handover delay in Fig. 6. That is, a handover delay of 1 second will result in 1 second of packets being lost. Assuming a G.711 voice codec sending at 50p/s, Fig. 7 and Fig. 8 show the packet loss in the downlink direction using (10) and (11), respectively.

With number of MANET hops up to 3, and number of nested MRs up to 2, the packet loss due to MANEMO handover should be acceptable for most users (up to 30 packets, about 600ms of voice). However as the size of the MANET or level of NEMO nesting increases, the loss can be significant. There are two methods to reduce the impact of handover packet loss: minimize the number of handovers and reduce the handover delay. The former comes at the expense of the MANEMO node using a sub-optimal interface; trade-offs will be explored as a part of future work. The latter is

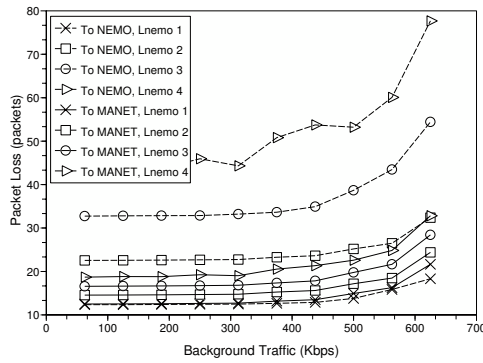
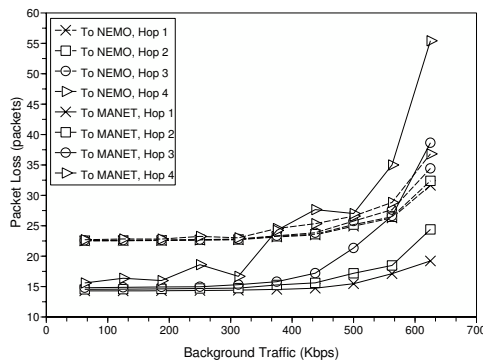
Fig. 7. Packet Loss from CN; $H_{MANET} = 2$ Fig. 8. Packet Loss from CN; $L_{NEMO} = 2$

possible in specific network scenarios, e.g. IPsec exchange can be reduced if keys exist on the new router.

Fig. 9 shows the effect of the delay within the Internet on the packet loss (similar results are obtained for both uplink and downlink packet loss). The main observation is that when handing over to NEMO, the delay to HAs can have significant impact on packet loss. With a delay between HA's of 50ms or more, the packet loss due to handover may be unacceptable for users if MRs are nested within NEMO. In general it is difficult for a MANEMO node to know the delay prior to handover, nor can it be limited to 50ms. However, for specific applications (e.g. vehicular networks where the majority of HAs may be located within a country, thereby limiting the delay) and by using optimal placement of HAs [13] the delay between HA's should be small enough to reduce the effect on handover packet loss.

VI. CONCLUSION

In heterogeneous wireless networks a mobile node or router should select the optimal network interface. A MANEMO node must select between a MANET, with potentially many wireless hops and high traffic load, and NEMO where sub-optimal routes via Home Agents are used. We have presented one of the first analyses of MANEMO handovers including: specified the minimal set of steps necessary for handing over to both MANET and NEMO gateways; defined the total delay and packet loss incurred with each handover; and used

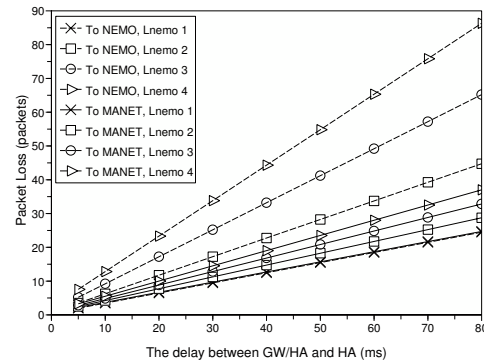

Fig. 9. Packet Loss vs Delay between GW/HA and HA vs Levels of NEMO

numerical examples to identify the key design factors for MANEMO handovers. This analysis is important in evaluating MANEMO handover algorithms, for which we have observed it is necessary for the MANEMO node to: know the level of nested Mobile Routers; estimate the delay between HAs and GWs; measure the load on the MANET. As future work we will evaluate protocols for obtaining this information, and develop a MANEMO handover algorithm that minimizes cost due to packet loss, end-to-end delay and other criteria.

ACKNOWLEDGMENT

This research was supported by the Telecommunications Research and Industrial Development Institute (TRIDI), National Telecommunications Commission (NTC), Thailand.

REFERENCES

- [1] R. Wakikawa, T. Clausen, B. McCarthy, and A. Petrescu, "MANEMO topology and addressing architecture," IETF Internet Draft (draft-wakikawa-manemoarch-00.txt), July 2007.
- [2] B. McCarthy, C. Edwards, and M. Dunmore, "Advances in MANEMO: Definition of the Problem Domain and the Design of a NEMO-Centric Approach," in *Proc. SAINT Workshops*, Japan, Jan. 2007, pp. 47–47.
- [3] V. Devarapalli, R. Wakikawa, A. Petrescu, and P. Thubert, "Network mobility (NEMO) basic support protocol," IETF RFC 3963, Jan. 2005.
- [4] D. Johnson and C. Perkins, "IP mobility support for IPv6," IETF RFC 3775, July 2007.
- [5] S. Noor and L. K. A. Zhang, "Route optimization techniques in network mobility (NEMO)," in *Proc. IFIP Intl. Conf. Wireless Optical Comm. Networks*, Singapore, July 2007, pp. 1–5.
- [6] S. Ding, "A survey on integrating MANETs with the Internet: Challenges and designs," *Computer Communications*, vol. 31, no. 14, pp. 3537–3551, 2008.
- [7] M. Tsukada, O. Mehani, and T. Ernst, "Simultaneous usage of nemo and manet for vehicular communication," in *Proc. TridentCom*, Innsbruck, Austria, 2008, pp. 1–8.
- [8] R. Wakikawa, R. Koodli, and A. Nilsson, "Design of Vehicle Network: Mobile Gateway for MANET and NEMO Converged Communication," in *Proc. VANET*, Cologne, Germany, Sep. 2005, pp. 81–82.
- [9] B. McCarthy, A. Petrescu, and T. H. Clausen, "MANEMO Configuration Problems (MCP)," IETF Internet Draft (draft-mccarthy-manemo-configuration-problems-00.txt), Mar. 2007.
- [10] A. Nilsson, C. Perkins, A. Tuominen, R. Wakikawa, and J. Malinen, "AODV and IPv6 Internet access for ad hoc networks," *Mobile Computing and Comm. Review*, vol. 6, no. 3, pp. 102–103, July 2002.
- [11] T. Mrugalski and J. Wozniak, "How to improve the efficiency of IPv6 handovers in IEEE 802.16 networks," in *Proc. ATNAC*, Adelaide, Australia, Dec. 2008, pp. 282–287.
- [12] "Internet traffic report," <http://www.internettrafficreport.com>.
- [13] R. Wakikawa, G. Valadon, and J. Murai, "Migrating home agents towards internet-scale mobility deployments," in *Proc. CoNEXT*, Lisboa, Portugal, 2006, pp. 1–10.