

Computational Study and Wear Prediction of Steam Turbine Blade with Titanium-Nitride Coating Deposited by Physical Vapor Deposition Method

Karuna Tuchinda, Sasithon Bland

Abstract—This work investigates the wear of a steam turbine blade coated with titanium nitride (TiN), and compares to the wear of uncoated blades. The coating is deposited on by physical vapor deposition (PVD) method. The working conditions of the blade were simulated and surface temperature and pressure values as well as flow velocity and flow direction were obtained. This data was used in the finite element wear model developed here in order to predict the wear of the blade. The wear mechanisms considered are erosive wear due to particle impingement and fluid jet, and fatigue wear due to repeated impingement of particles and fluid jet. Results show that the life of the TiN-coated blade is approximately 1.76 times longer than the life of the uncoated one.

Keywords—Physical vapour deposition, steam turbine blade, titanium-based coating, wear prediction.

I. INTRODUCTION

STEAM turbine blades used in steam-electric power stations are inevitably suffered from wear, in which the main wear mechanism is erosion [1], [2]. The material degradation results in poor process performance and attempts have been made to analyze the erosive wear [3]-[5] and to improve the wear resistance of the blades [6]-[8]. The use of thin film coating to enhance the wear resistance of materials are widely known in various applications [9]-[11], including in power generation industry [12], [13]. Titanium-based coatings such as TiN, TiAlN, TiCN are the well-known choices where elevated temperature is involved [14]-[16]. This work aims to develop a model to predict the wear behavior of the TiN-coated steam turbine blade compared to that of the uncoated blade. The blade considered is from the last stage of a steam electric power system and is shown in Fig. 1. The wear is clearly observed along the edge of the blade.

II. CHARACTERIZATION OF COATING MATERIAL PROPERTIES

The blade is made of stainless steel SUS403. The coating considered in this work is Titanium nitride (TiN). Mechanical and tribological properties of TiN coating on samples were obtained from experiments following the methods of [17]-[19]. Temperature range considered was between 25-300°C.

Karuna Tuchinda was with the Department of Tool and Materials Engineering, Faculty of Engineering, King Mongkut's University of Technology Thonburi, Thailand

Sasithon Bland is with the Department of Production Engineering, Faculty of Engineering, King Mongkut's University of Technology North Bangkok, Thailand (e-mail: sstp@kmutnb.ac.th).

The average coating thickness of 2.6 μm was obtained from Calotest [20]. Nano-micro indentation tester together with CSM technique was employed to determine the hardness and Young's modulus of TiN at different temperature. These are shown in Table I. The elasto-plastic flow curve was also determined based on the load-displacement and final area of contact obtained from such test. Scratch test was performed and revealed that the coating started to fracture at the load of 33 N and delaminate at the load of 80 N. Table II shows the coefficient of friction and wear rate of the coating at two contacting stress levels applicable to the load range that the blade is undergone.

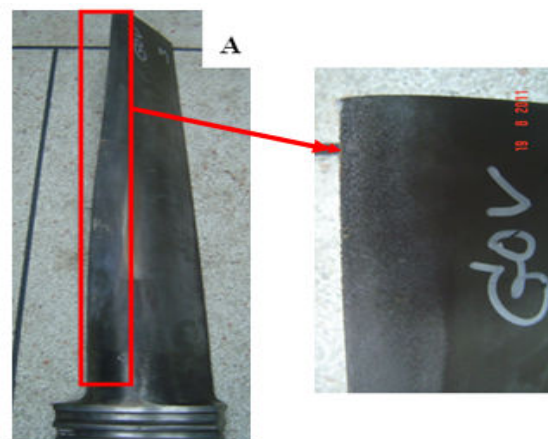

Fig. 1 Steam turbine blade showing damage caused by wear along the edge of the blade

TABLE I
HARDNESS AND YOUNG'S MODULUS OF TiN OBTAINED EXPERIMENTALLY

Testing temperature (°C)	Hardness (HV)	Surface hardness $H_{0.1}$ (GPa)	Young's modulus (GPa)
25	2423±400	26.18±4.21	350±50
100	2155±397	23.22±3.13	506±198
200	2432±218	25.15±2.25	505±199
300	2108±270	22.75±2.97	817±99

TABLE II
TiN COEFFICIENT OF FRICTION AND WEAR RATE OBTAINED EXPERIMENTALLY

Load (N)	Contact pressure (MPa)	Coefficient of friction		Wear rate (mm ³ /mm)	
		25°C	300°C	25°C	300°C
1	1119	0.3	0.16	6.95×10^{-11}	1.645×10^{-8}
5	1777	0.5	0.3	4.71×10^{-9}	8.2×10^{-8}

III. SIMULATION OF BLADE WORKING CONDITIONS

The flow of superheated steam through the blade was simulated using a finite volume model developed in this work. The inlet and outlet temperatures were 197°C and 167°C, respectively. The inlet and outlet pressure were 0.2214 bar and 0.0771 bar, respectively. The temperature and pressure were obtained from actual measurements of flow in operation. Rotational speed was 3000 rpm. Fig. 2 shows the blade assembly used in the simulated model. The following values were obtained from the analysis and they are used in the wear model described in the following section; interface pressure and temperature on the blade surface, flow velocity and flow angle in the proximity to the blade surface.

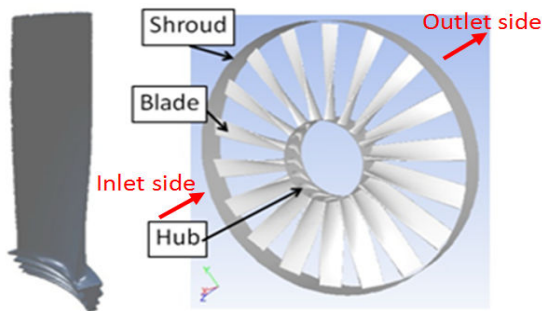

Fig. 2 Blade assembly used in the finite volume model

IV. COMPUTATIONAL WEAR MODEL AND WEAR PREDICTION

A. Particle-Induced Wear Model

The wear of the blade from foreign particles in the steam flow was analyzed using finite element models. The particles are mostly found as metal oxide due to thermal oxidation involved in the working history of the system. FE models representing the collision of a 25 μm diameter spherical particle onto either uncoated SUS403 or TiN-coated SUS403 surface were developed. Fig. 3 shows the particle and the surface during the collision. The particle was modeled as discrete rigid element. Parametric study was carried out in order to examine the effect of varying impact angle, speed and surface temperature on the wear of the uncoated and coated surface. The range of impact angle considered were 0-90 degree from contact plane, whereby zero degree represents sliding over the surface and 90 degree represents direct front-on impact. The particle speed was varied between 10-500 m/s and the surface temperature was varied between 25-250°C. The range of speed and temperature was chosen such that they represent respective values on the blade obtained from section III.

The element on the surface will be removed if its failure index is 1 or higher. The failure index is the ratio of equivalent plastic strain to the material's elongation at break. The wear volume can then be calculated from the volume of the removed elements. The wear depth per one collision is measured from the deepest point of wear in the surface as shown in Fig. 4.

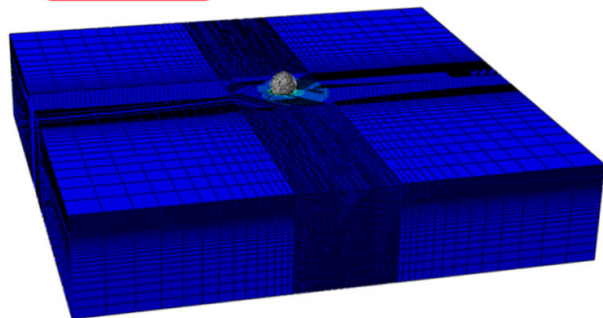
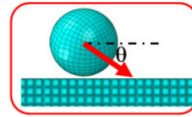

Fig. 3 FE collision model showing particle and surface

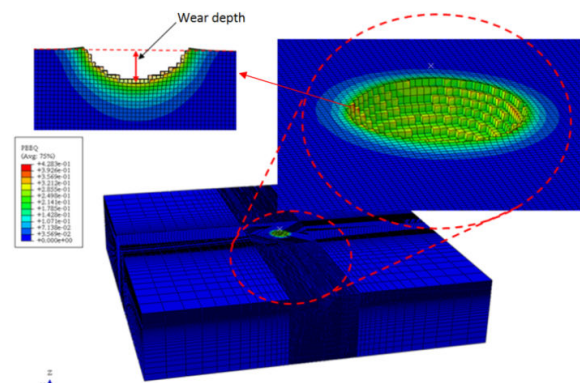

Fig. 4 The surface with elements removed due to material failure and the measurement of wear depth

It was found that at low speed, i.e. 10 m/s, no wear was found on either uncoated or coated SUS403 for all impact angles. Uncoated SUS403 starts to wear at the speed of 50 m/s whereas the coated surface starts to wear at the speed of 500 m/s. The wear volume for both uncoated and coated SUS403 as a function of impact angle is shown in Fig. 5 and Fig. 6. It can be seen that at high speed (greater than 250 m/s), the wear volume is hardly affected by the impact angle, given the angle is higher than 20 degree for the uncoated case and 45 degree for the coated case. In all cases, higher temperature will result in lower wear. This is expected as the effect of increase in material toughness

In addition, fatigue wear due to repeated impingement of particles was also considered for cases in which no surface wear under single collision was shown. The fatigue wear rate was calculated according to (1) which is based on Archard's equation [21].

$$\dot{W} = k(T)Pv \quad (1)$$

where \dot{W} is sliding fatigue wear rate (mm/s), $k(T)$ is temperature-dependent specific wear coefficient obtained from experiment, P is contact pressure and v is sliding velocity. The total wear rate therefore is a combination of single

particle impingement wear and fatigue particle induced wear. The wear from single particle collision is adjusted by a correction factor which takes into account the probability of actual collision of particles.

to surface crack initiation is also possible due to variation of particle size and irregular shape. This influence is likely to be more significant when the impact angle is high. However, as the trend shows, the particle-induced wear model can be used to compare the wear rate of the coated and uncoated turbine blade. This is described in Section V.

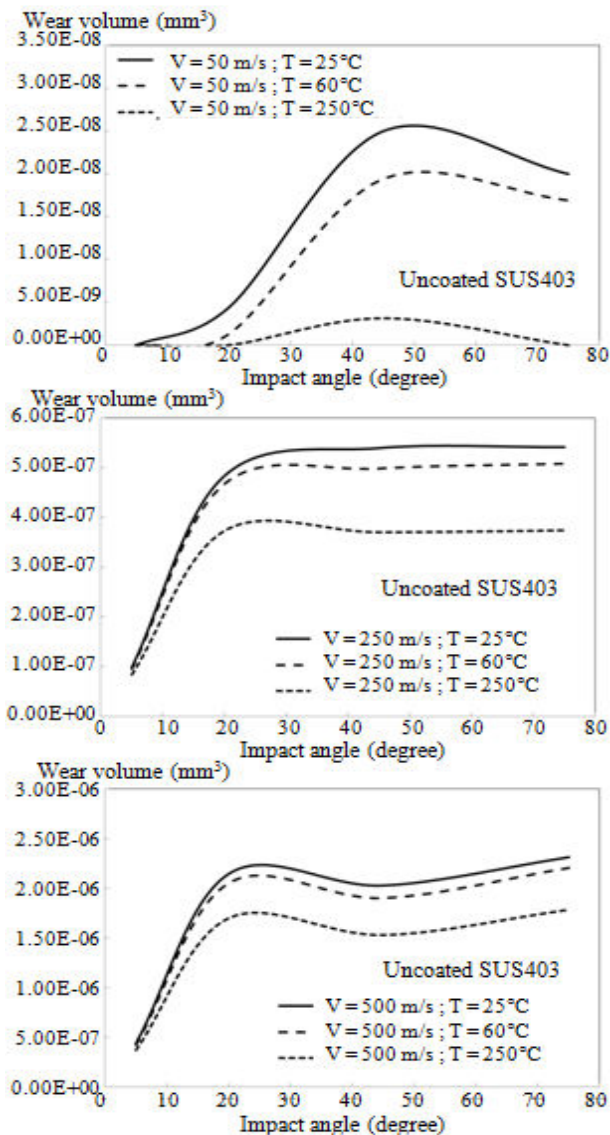

Fig. 5 The wear volume at different impingement angles, impingement speed and temperature for uncoated SUS403

The calculated wear rate for both coated and non-coated surface was validated with experiment results where the water jet mixed with aluminum oxide particles was blasted onto SUS403 and TiN-coated SUS403 samples. The angle of impingement was varied and the wear rate of both types of samples was measured. The comparison is shown in Fig. 7. The experimental wear rate at large impact angle is higher than that of the simulation. This could be due to the fact that the simulation model does not take into account loading history effect on defect propagation which could raise the fatigue wear severity. In addition, stress concentration leading

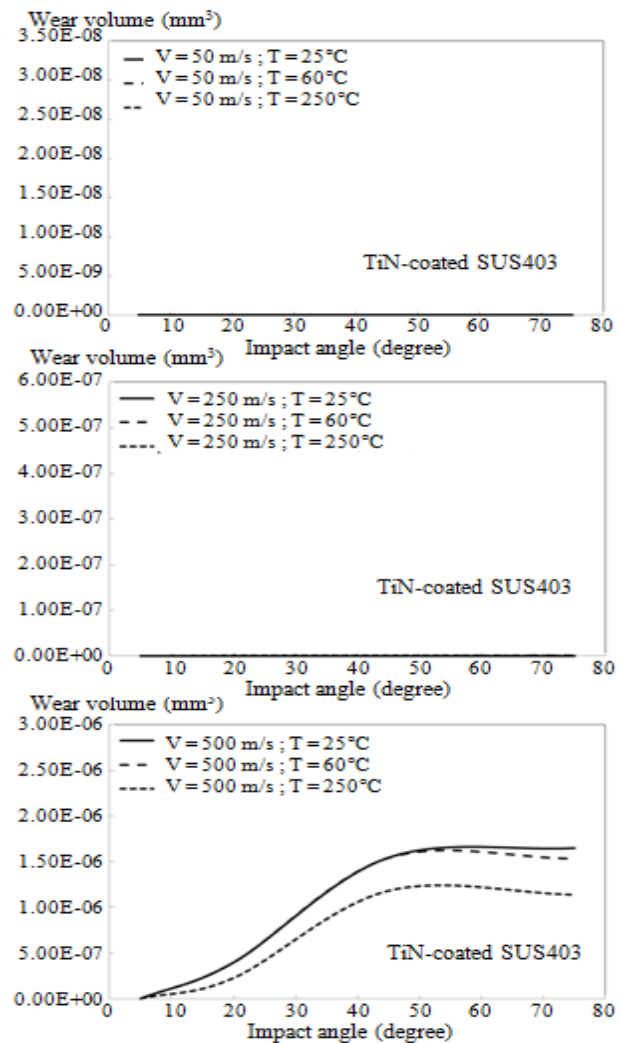

Fig. 6 The wear volume at different impingement angles, impingement speed and temperature for TiN-coated SUS403

B. Fluid-Induced Wear Model

The wear of blade from the steam flow was analyzed using finite element models. FE models consisting of fluid jet projecting onto the surface at various temperatures, pressure and speed were developed as shown in Fig. 8. The range of temperature, pressure and speed of the jet was chosen such that they represent respective values on the blade obtained from section III. Von Mises stress and normal stress of the surface area which is in contact with the fluid jet were calculated, an example of which is shown in Fig. 9.

It was found that the normal stress is directly proportional to fluid pressure for all velocities and temperatures. One

example is shown in Fig. 10, in which the fluid jet having the velocity of 500 m/s is projected onto TiN-coated SUS403. The influence of fluid velocity on the stress is less strong than that of the pressure as can be seen in Fig. 11. Increasing velocity only slightly increases the normal stress. This is the case for both SUS403 and TiN coated SUS403. Furthermore, fluid jet fatigue wear was also calculated in the same way as the particle fatigue wear.

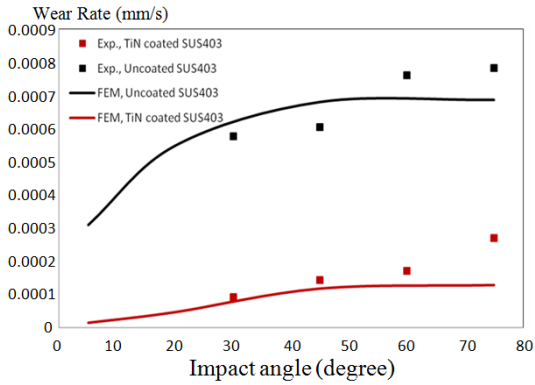

Fig. 7 Comparison of wear rate calculated from FEM and from experiments

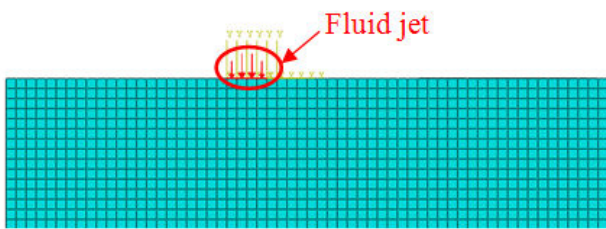

Fig. 8 FE model showing fluid jet projecting onto surface

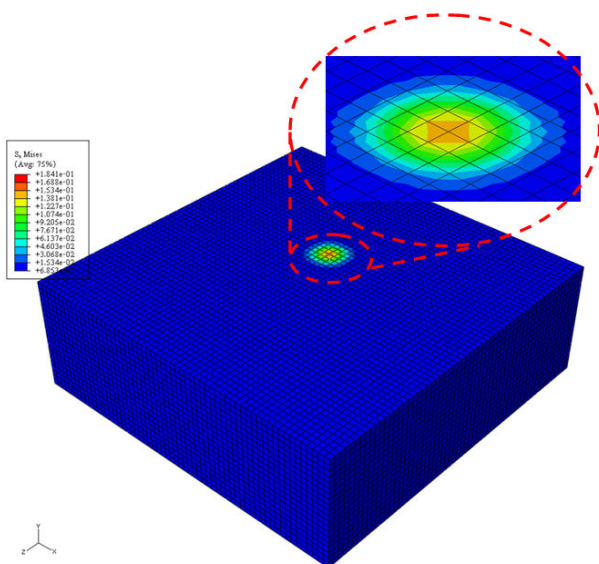

Fig. 9 Von mises stress due to fluid jet projecting onto SUS403 surface

V. PREDICTION OF WEAR ON STEAM TURBINE BLADE

The wear rate on all surface area of the uncoated and TiN-coated turbine blade was calculated using simulation results from Section III and the model described in section IV. Fig. 12 shows the wear rate of particle induced wear, fluid induced wear and total wear for both uncoated and TiN-coated blades. It can be seen that fluid-induced wear hardly contributes to the total wear on blades. The particle erosion is the predominant wear mechanism and takes place mostly along the left edge of the blade. This is in agreement with the wear observed from actual blades (compared to Fig. 1). By using TiN coating, the overall wear is reduced and the life of the blade can be enhanced by 1.76 times. The lifetime calculation is based on the wear at the most critical point where maximum wear occurs.

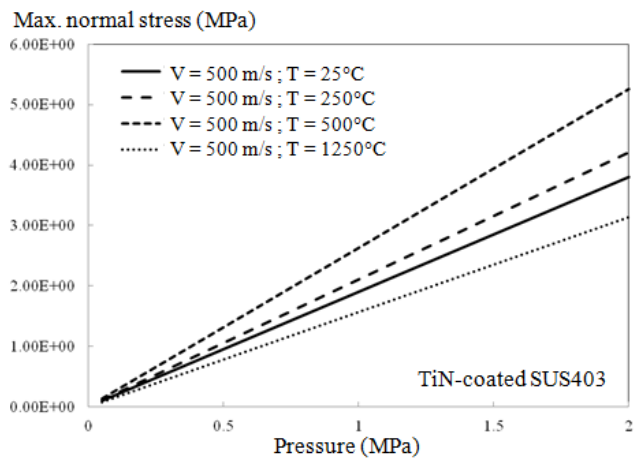

Fig. 10 Normal stress on TiN-coated SUS403 due to fluid jet of velocity 500 m/s at different pressure and temperature

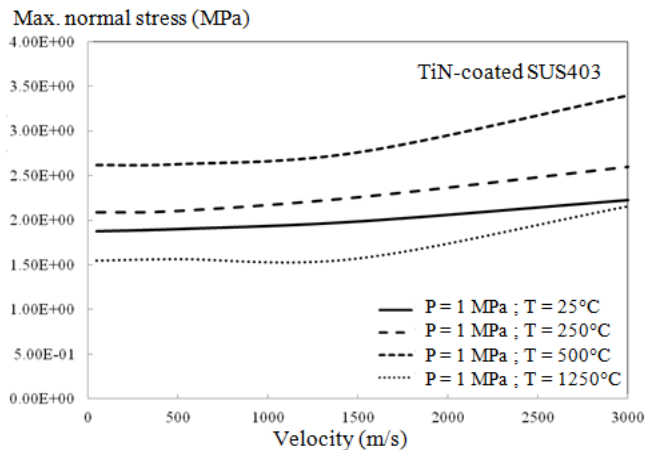

Fig. 11 Normal stress on TiN-coated SUS403 due to fluid jet of pressure 1 MPa at different velocity and temperature

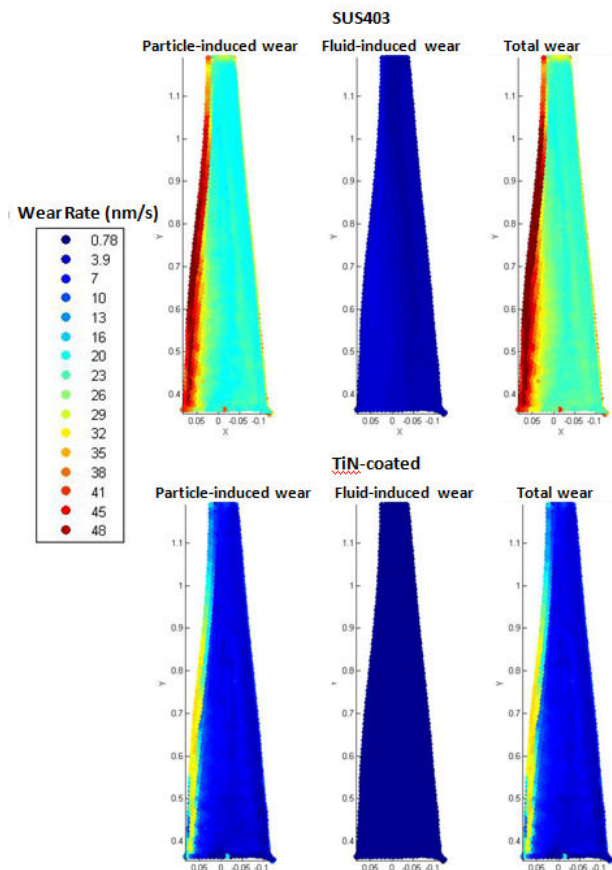

Fig. 12 Particle-induced wear and fluid-induced wear and total wear of uncoated and coated blades

VI. CONCLUSION

This paper describes the method and the model to calculate the wear of steam turbine blade with and without TiN coating. Firstly, the finite volume model was developed in order to simulate the working conditions of the blade. Simulation results were then used in the computational wear model to calculate the wear level of the blade surface. Erosive wear due to particles and fluid jet, as well as fatigue wear were calculated. It was found that the wear was predominantly caused by particles impingement. The use of TiN coating can increase the lifetime of the blade by as much as 1.76 times.

ACKNOWLEDGMENT

The authors thank Electricity Generation Authority of Thailand for financial support (grant no. 53-B104000-046-IO.SS03A3008076-KMUTT) and data. We also thank NanoShield& Royal Ace Co. Ltd. for their invaluable support of coating of blades and samples.

REFERENCES

[1] Wei-Ze Wang, Fu-Zhen Xuan, Kui-Long Zhu, Shan-Tung Tu, (2007), Failure analysis of the final stage blade in steam, *Engineering Failure Analysis*, Volume 14, Issue 4, Pages 632-641

- [2] J Dehouve, P Nardin, M Zeghami, (1999), Erosion study of final stage blading of low pressure steam turbines, *Applied Surface Science*, Volumes 144–145, Pages 238-243
- [3] C.R.F. Azevedo, A. Sinátoro, (2009), Erosion-fatigue of steam turbine blades, *Engineering Failure Analysis*, Volume 16, Issue 7, Pages 2290-2303
- [4] B. Staniša, V. Ivušić, (1995) Erosion behaviour and mechanisms for steam turbine rotor blades, *Wear*, Volumes 186–187, Part 2, Pages 395-400
- [5] Zdzislaw Mazur, Rafael Garcia-Illescas, Jorge Aguirre-Romano, Norberto Perez-Rodriguez, (2008), Steam turbine blade failure analysis, *Engineering Failure Analysis*, Volume 15, Issues 1–2, Pages 129-141
- [6] Z. Mazur, R. Campos-Amezcuca, G. Urquiza-Beltrán, A. García-Gutiérrez, (2004), Numerical 3D simulation of the erosion due to solid particle impact in the main stop valve of a steam turbine, *Applied Thermal Engineering*, Volume 24, Issue 13, Pages 1877-1891
- [7] B.S. Mann, VivekArya, (2003), HVOF coating and surface treatment for enhancing droplet erosion resistance of steam turbine blades, *Wear*, Volume 254, Issues 7–8, Pages 652-667
- [8] B.S Mann, (1999), Solid-particle erosion and protective layers for steam turbine blading, *Wear*, Volume 224, Issue 1, Pages 8-12
- [9] Hugh O. Pierson, (1992), 11 - CVD in Wear-, Erosion-, and Corrosion-Resistant Applications, *Handbook of Chemical Vapor Deposition*, Pages 347-385
- [10] Subbiah Ramalingam, (1996), Emerging applications and new opportunities with PVD Arc sources, *Handbook of Vacuum Arc Science and Technology*, Pages 519-551
- [11] ZhengRongShui, Bu Qian Wang, Alan V. Levy, (1990), Erosion of protective coatings, *Surface and Coatings Technology*, Volumes 43–44, Part 2, Pages 875-887
- [12] John Stringer, (1998), Coatings in the electricity supply industry: past, present, and opportunities for the future, *Surface and Coatings Technology*, Volumes 108–109, Pages 1-9
- [13] Y.I. Oka, H. Miyata, (2009), Erosion behaviour of ceramic bulk and coating materials caused by water droplet impingement, *Wear*, Volume 267, Issue 11, Pages 1804-1810
- [14] P. C. Jindal, A. T. Santhanam, U. Schleinkofer, A. F., (1999), Shuster, Performance of PVD TiN, TiCN, and TiAlN coated cemented carbide tools in turning, *International Journal of Refractory Metals and Hard Materials*, Volume 17, Issues 1-3, Pages 163-170
- [15] J. D. Bressan, R. Hesse, E. M. Silva Jr., (2001), Abrasive wear behavior of high speed steel and hard metal coated with TiAlN and TiCN, *Wear*, Volume 250, Issues 1-12, Pages 561-568
- [16] T. Polcar, T. Kubart, R. Novák, L. Kopecký, P. Široký, (2005), Comparison of tribologicalbehaviour of TiN, TiCN and CrN at elevated temperatures, *Surface and Coatings Technology*, Volume 193, Issues 1-3, Pages 192-199
- [17] Tunvisut, K., O'Dowd, N.P. and Busso, E.P., (2001), Use of scaling functions to determine mechanical properties of thin coatings from microindentation tests, *Int. J. Solids Struct.* 38 (2) pp. 335–351.
- [18] Tunvisut, K., Busso, E.P., O'Dowd, N.P. and Brantner, H.P., (2002). Determination of the mechanical properties of metallic thin films and substrates from indentation tests. *Philosophical Magazine A* 82,, pp. 2013–2023
- [19] Tuchinda, K., (2011), Determination of stress-strain relationship of hard thin films on steel substrate from indentation tests – Industrial application., To be submitted to *Surface & coatings Technology* for publication.
- [20] http://www.csm-instruments.com/en/Coating_thickness
- [21] Archard, J.F. (1953). Contact and Rubbing of Flat Surface. *J. Appl. Phys.* Vol. 24, pp. 981–988.