

Computational Evaluation of a C-A Heat Pump

Young-Jin Baik, Minsung Kim, Young-Soo Lee, Ki-Chang Chang, and Seong-Ryong Park

Abstract—The compression-absorption heat pump (C-A HP), one of the promising heat recovery equipments that make process hot water using low temperature heat of wastewater, was evaluated by computer simulation. A simulation program was developed based on the continuity and the first and second laws of thermodynamics. Both the absorber and desorber were modeled using UA-LMTD method. In order to prevent an unfeasible temperature profile and to reduce calculation errors from the curved temperature profile of a mixture, heat loads were divided into lots of segments. A single-stage compressor was considered. A compressor cooling load was also taken into account. An isentropic efficiency was computed from the map data. Simulation conditions were given based on the system consisting of ordinarily designed components. The simulation results show that most of the total entropy generation occurs during the compression and cooling process, thus suggesting the possibility that system performance can be enhanced if a rectifier is introduced.

Keywords—Waste heat recovery, Heat Pump.

I. INTRODUCTION

THE dyeing industry is a high energy consuming industry where a significant amount of hot water is required due to the process characteristics. Fig. 1 depicts a schematic diagram of process water and wastewater flows in the dyeing process. The water used in the dyeing process is gathered in a hot water storage tank (about 45°C in the summer), is heated while passing a boiler along with city water, and then is reused in the dyeing process. At the same time, the process generates a significant amount of wastewater. The average temperature reaches 50°C in summer, although this varies depending on the products. As shown in the figure, wastewater is gathered in the wastewater storage tank and is discharged to the wastewater disposal plant after being cooled down. In this situation, if the heat of wastewater is utilized as the energy source to make hot water for process, as marked by the dotted line, then the cost for heating and cooling will be reduced and the cost for high

temperature penalty will be avoided at the same time.

Currently, the most widely used commercial methods to generate high temperature heat using low temperature heat as a heat source are the vapor compression heat pump and the absorption heat pump. In the case of a vapor compression heat pump, fluorocarbon, hydrocarbon, and natural refrigerants are used as working media. Most of the fluorocarbon group has high vapor pressure, so they are not suitable for the high temperature application. Moreover, due to recent environmental issues, its application is rather limited. The application of the hydrocarbon group is also limited to domestic usage because of its flammability. Among natural refrigerants, water has a low vapor pressure and no flammability, making it suitable for high temperature industrial applications. However, its relatively large specific volume requires huge scale multi-stage compressor.

The typical process in summer is to heat process water from 45°C up to 90 ~ 100°C, while cooling wastewater from 50°C down to the ambient temperature. Therefore, if the pure refrigerant is employed as primary working fluid, the loss of available energy in heat transfer process will be not negligible due to the temperature glide discrepancy between the working fluids. Consequently, it is necessary to use the mixture of refrigerant and an absorber, for which the discrepancy in boiling points is large enough to match the temperature glides. Due to these reasons, in this study, a CAHP that uses ammonia/water as working fluids is considered for the aforementioned process.

In this study, the system performance and operating conditions of ammonia/water CAHP for the dyeing process in summer were computed through the simulation, and the results were analyzed to investigate the possibility of CAHP application. Also, the entropy generation rates in each component for various conditions were computed in order to find the reasons for the decrease of the system performance.

II. ANALYSIS AND SIMULATION OF THE CAHP

Fig. 2 depicts a schematic diagram of a CAHP generating process hot water using dyeing wastewater as a heat source. The working principles are as following. First, in a desorber, chiefly ammonia with high vapor pressure in ammonia-water mixture is evaporated using dyeing wastewater as a heat source; then the mixture gets separated into liquid and vapor in a separator. The separated liquid and the vapor get high-pressured by the solution pump and the compressor respectively. Here, the compressor cylinder head and oil cooling may be needed to prevent damage to the oil and system. The high-pressured vapor and solution are then combined at the

Young-Jin Baik is with the High Efficiency and Clean Energy Research Division, Daejeon 305-343, Korea (phone: +82-42-860-3226; fax: +82-42-367-5067; e-mail: twinjin@kier.re.kr).

Minsung Kim is with the High Efficiency and Clean Energy Research Division, Korea Institute of Energy Research, Daejeon 305-343, Korea (Corresponding author, phone: +82-42-860-3062; fax: +82-42-367-5067; e-mail: minsungk@kier.re.kr).

Young-Soo Lee is with the High Efficiency and Clean Energy Research Division, Daejeon 305-343, Korea (phone: +82-42-860-3161; fax: +82-42-367-5067; e-mail: yslee@kier.re.kr).

Ki-Chang Chang is with the High Efficiency and Clean Energy Research Division, Daejeon 305-343, Korea (phone: +82-42-860-3163; fax: +82-42-367-5067; e-mail: kcchang@kier.re.kr).

Seong-Ryong Park is with the High Efficiency and Clean Energy Research Division, Daejeon 305-343, Korea (phone: +82-42-860-3224; fax: +82-42-367-5067; e-mail: spark@kier.re.kr).

inlet of an absorber, and the absorption process occurs. The heat generated during the absorption of vapor is used to generate process hot water (90 ~ 100°C). Then the strong solution goes through the expansion valve and returns to the desorber. In a solution heat exchanger, heat exchange occurs between the high temperature strong solution and low temperature weak solution.

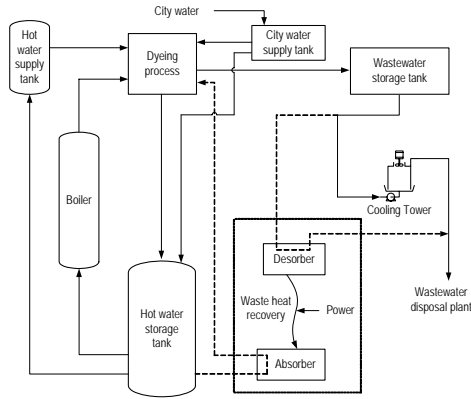

Fig. 1 Schematic diagram of process water and wastewater flows in the dyeing process

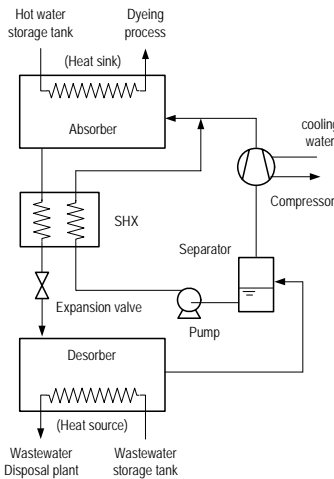

Fig. 2 Schematic diagram of a CAHP in dyeing process

In order to evaluate the system computationally, each component is modeled by (1)~(4) using continuity, the first law of thermodynamics and the second law of thermodynamics.

$$\text{working fluid mass balance : } \sum (\dot{m}x)_{in} - \sum (\dot{m}x)_{out} = 0 \quad (1)$$

$$\text{overall mass balance : } \sum \dot{m}_{in} - \sum \dot{m}_{out} = 0 \quad (2)$$

$$\text{energy balance : } \sum (\dot{m}h)_{in} + W - \sum (\dot{m}h)_{out} - Q = 0 \quad (3)$$

$$\text{entropy generation rate : } s = \sum (\dot{m}s)_{out} - \sum (\dot{m}s)_{in} - \sum \frac{Q}{T_{avg}} \quad (4)$$

Applying the first and second laws of thermodynamics to the whole system yields (5) and (6). The system COP, or useful heat output over the total energy input, is defined as (7).

$$Q_{abs} + Q_{cool} - Q_{des} - W_{comp} - W_{pump} = 0 \quad (5)$$

$$\sum S = \frac{Q_{abs}}{T_{avg,abs}} + \frac{Q_{cool}}{T_{avg,cool}} - \frac{Q_{des}}{T_{avg,des}} \quad (6)$$

$$COP = \frac{Q_{abs}}{W_{comp} + W_{pump}} \quad (7)$$

In (4) and (6), T_{avg} is the entropic average temperature that represents the transport of entropy associated with a non-isothermal heat transfer process and is defined as (8).

$$T_{avg} = \frac{Q_{1 \rightarrow 2}}{\int_1^2 \frac{\delta Q}{T}} \quad (8)$$

The following assumptions are included in the model: (1) All heat exchangers have a counter-flow configuration. (2) Absorber and separator outlets are saturated. (3) Mixing and separation are adiabatic processes up to the equilibrium state. (4) Pressure drops and heat losses are neglected. (5) The solution pump has constant isentropic efficiency of 65%.

A single-stage oil-lubricated reciprocating compressor with a water-cooled cylinder head currently commercially available was considered. In a separator, a minute amount of water is evaporated with ammonia and goes into the compressor. However, under most operating conditions, only around 1% of water content appears. Therefore, with an assumption of the same efficiency as with pure ammonia [1], an isentropic efficiency was obtained as polynomial of suction and discharge pressure from the compressor map data. For the prevention of oil aging and the safety of the compressor, discharge gas temperature should be limited within a certain value, or 140°C in this study. For this purpose, a proper cooling process is required in actuality, and was assumed to occur after the compression process. Here, the cooling water inlet and outlet temperatures were set to be 30°C and 50°C.

The absorber and desorber heat loads were divided into 10 segments respectively and UA-LMTD method was employed at each segment to prevent an unfeasible temperature profile in the absorber and to reduce errors. Since UA distribution is minor issue in CAHP [1], the UAs of the absorber and desorber were also set at 12 and 10 kW/K respectively. The solution heat exchanger (SHX) was modeled by the given UA and e-NTU relation. The UA of the SHX was fixed at 1.1 kW/K, which was 5% of the sum of the absorber and desorber UA. Itard [2] and Hultén and Berntsson [1] suggested a 4~13% as an optimum value range. An expansion was considered as an isenthalpic process.

Q_{des} , desorber heat capacity, was set at 100 kW throughout the simulation. The maximum pressure was limited to be lower than 2,300 kPa in consideration of using ordinarily designed components, and safety concerns. The model was programmed using the EES(Engineering Equation Solver) [3].

Once the input parameters are given, it is possible to compute the optimal operating point at which the COP is maximized under the given conditions. The optimal point was found by carrying out the simulation with the change of a dTabs,

or temperature gradient in the absorber. In actuality, dT_{abs} was determined in accordance with the physical size of each component, the concentration and the charge amount of ammonia, and so on. As the results of the simulation, an absorber heating capacity, compressor and pump power, a compressor cooling load, a COP and an entropy generation rate in each component were obtained.

III. RESULTS AND DISCUSSION

Fig. 3 presents the temperatures of the primary working fluid over dT_{abs} changes at absorber pressure of 2,300 kPa with $T_{sink, in} = 45^\circ\text{C}$, $T_{sink, out} = 100^\circ\text{C}$, $T_{src, in} = 50^\circ\text{C}$, and $T_{src, out} = 25^\circ\text{C}$. As dT_{abs} increases, dT_{des} tends to increase, and the extent of change is very large. This characteristic of CAHP shows that when the external temperature gradient is large as in the dyeing process, system performance can be improved by matching the temperature glides between working fluids to minimize irreversibility in the heat exchange process. Through a solution heat exchange, the temperature of weak solution from the desorber, is heated up to $T_{shx, out(weak)}$. At the same time, the temperature of strong solution from the absorber is cooled down to $T_{exp, in}$. As dT_{abs} increases, the difference between $T_{abs, out}$ and $T_{shx, out(weak)}$ decreases. This is because the solution flow in a SHX decreases, whereas UA is fixed. When dT_{abs} is more than about 40°C , there is almost no difference, which means that a SHX in this case is larger than enough. On the other hand, a bigger SHX is needed if the external temperature glides are rather small.

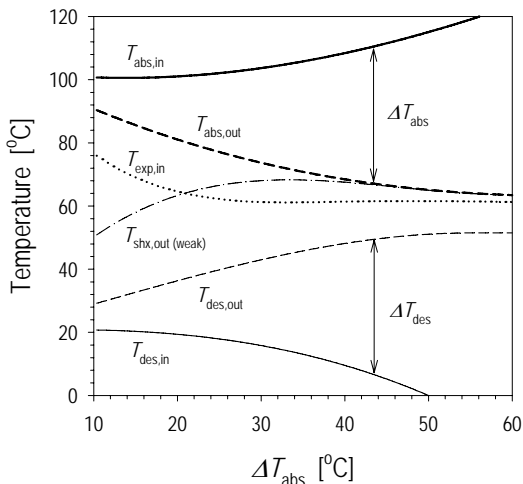

Fig. 3 Temperatures of primary working fluid over the change of dT_{abs}

Fig. 4 presents S , entropy generation rate, in each component under the above condition. The rate of S against to total S changes according to dT_{abs} . The distributions are $S_{comp} = 27\sim 35\%$, $S_{cool} = 27\sim 45\%$, $S_{abs} = 5\sim 15\%$, $S_{des} = 2\sim 13\%$, $S_{exp} = 7\sim 12\%$, $S_{mix} = 1\sim 7\%$, $S_{shx} = 0\sim 4\%$, and $S_{pump} = 0\sim 1\%$. It is apparent that S during the compression and compressor cooling processes are mainly responsible for total S . For the S_{cool} and S_{comp} , there exists a minimal point, under

the influence of the external temperature glide, at the point where the system pressure ratio is minimized. The pressure ratio increases as away from this optimum point, and consequently, entropy generation during the compression increases. It also leads to an increase of discharge gas temperature and an increase of S_{cool} . Especially for S_{comp} , in the range of where dT_{abs} is small, more rapid increase rate is apparent than in large dT_{abs} area, which is because the flow increases as dT_{abs} decreases. The reason for the rapid increase of S_{cool} compared to S_{comp} in the large dT_{abs} area, despite the flow decrease, is that the decrease of isentropic efficiency is great, whereas the decrease of flow is gradual.

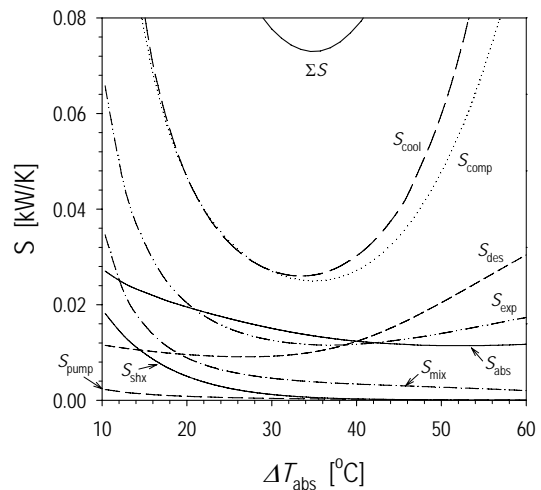

Fig. 4 Entropy generation rate in each component over dT_{abs} changes

S_{abs} starts around 0.027 kW/K and shows a tendency of decreasing as dT_{abs} increases, with a minimal value at around $dT_{abs} = 50^\circ\text{C}$, and then increasing again. The reason for the large S in the area of small dT_{abs} is the increased flow, as in the compression process. On the other hand, S increases slightly in the large dT_{abs} area because of the temperature glide mismatch. S_{exp} also exhibits the same tendency, but the increase is very rapid in the small dT_{abs} area. This is because it is influenced not only by the flow but also by the pressure difference. The reason that S_{exp} increases again in the area of large dT_{abs} is also the pressure difference increases. A S_{des} can be explained by the temperature glide mismatch and flow as well.

S_{mix} has a large portion in the area of small dT_{abs} . S_{mix} increases as the temperature difference and concentration difference between weak solution and gas increase. S_{shx} and S_{pump} have a similar tendency. They have large values in the area of small dT_{abs} and decrease as dT_{abs} increases. A S_{shx} can also be explained from the view point of effectiveness of heat exchanger. In the area of small dT_{abs} , due to a large solution flow, the effectiveness decreases, which decreases the overall efficiency of the system. For example, in this case, the effectiveness of the SHX at the optimal dT_{abs} reaches 88%, but as dT_{abs} decreases, the effectiveness decreases to 33% at

$dT_{\text{src}} = 10^\circ\text{C}$.

In this study, a conceptual design of water-cooled rectifier between a separator and a compressor was considered in order to decrease the suction gas temperature and to increase the ammonia concentration at the same time. It was assumed that the rectification is an adiabatic process up to the equilibrium state and the outlets are saturated. A rectifying is described by (1)~(4) and the UA-LMTD method. The first laws of thermodynamics of the whole system turn into (5) with the term of “+ Q_{rec}” on the left hand side of it. The second law yields (6) with the term of “+ Q_{rec} / T_{avg, rec}” on the right hand side. Inlet and outlet temperature of the water for rectifying were given as 25 °C and 30 °C, respectively.

- [2] Itard L. "Wet compression versus dry compression in heat pumps working with pure refrigerants or non-azeotropic mixtures," *Int J Refrig* 1995;18:495-504.
- [3] Klein S. EES (Engineering Equation Solver) V7.345. web site: <http://www.fChart.com>; 2005.

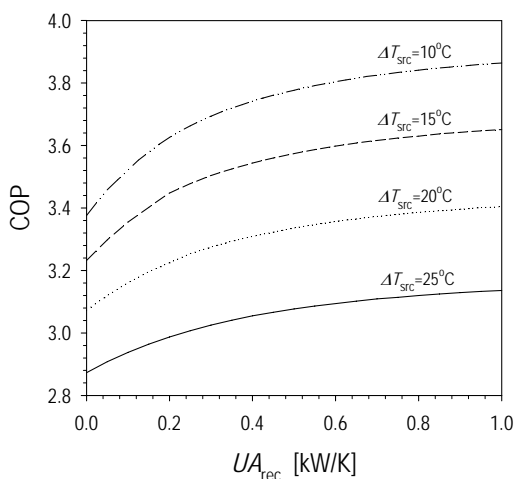

Fig. 5 COP variations in accordance with the changes of dT_{src} and UA_{rec}

Fig. 5 depicts the change of COP in accordance with the changes of dT_{src} and UA_{rec} . The larger dT_{src} is, the lesser the performance improvement resulted from UA_{rec} increase is. This is because of the drop of Q_{rec} following the decrease of temperature difference between the fluids in the rectifier due to the lowered equilibrium temperature along with the decrease of the wastewater outlet temperature. According to Fig. 5, if enough rectifying is assumed, the maximum of about 15% of performance improvement can be expected.

IV. CONCLUSION

A C-A heat pump was evaluated by the simulation. In the typical case of summer, if the system is well optimized, then 5% of the total UA is enough for UA of a SHX. Most of the total entropy generation occurs during the compression and cooling processes, and grows rapidly as the hot water exit temperature increases. System performance can be improved by the introduction of a rectifier.

REFERENCES

- [1] Hultén M, Berntsson T. "The compression/absorption cycle - influence of some major parameters on COP and a comparison with the compression cycle," *Int J Refrig* 1999;22:91-106.