

Comparison of Field-Oriented Control and Direct Torque Control for Permanent Magnet Synchronous Motor (PMSM)

M. S. Merzoug, and F. Naciri

Abstract—This paper presents a comparative study on two most popular control strategies for Permanent Magnet Synchronous Motor (PMSM) drives: field-oriented control (FOC) and direct torque control (DTC). The comparison is based on various criteria including basic control characteristics, dynamic performance, and implementation complexity. The study is done by simulation using the Simulink Power System Blockset that allows a complete representation of the power section (inverter and PMSM) and the control system. The simulation and evaluation of both control strategies are performed using actual parameters of Permanent Magnet Synchronous Motor fed by an IGBT PWM inverter.

Keywords—PMSM, FOC, DTC, hysteresis, PWM.

I. INTRODUCTION

PERMANENT magnet (PM) synchronous motors have attracted increasing interest in recent years for industrial drive application. The high efficiency, high steady state torque density and simple controller of the PM motor drives compared with the induction motor drives make them a good alternative in certain applications. Moreover, the availability of low-cost power electronic devices and the improvement of PM characteristics enable the use of PM motors even in some more demanding applications [1].

It is now recognized that the two high-performance control strategies for PMSM are field-oriented control (FOC) and direct torque control (DTC). They have been invented respectively in the 70's and in the 80's. These control strategies are different on the operation principle but their objectives are the same. They aim both to control effectively the motor torque and flux in order to force the motor to accurately track the command trajectory regardless of the machine and load parameter variation or any extraneous disturbances. Both control strategies have been successfully implemented in industrial products.

The supporters of field-oriented control and direct torque control claim the superiority of their strategy versus the other. Up to now, the question has not been clearly answered. The purpose of this paper is to present a comparative study on these two control strategies in order to clarify the "myth". The comparison is based on various criteria including basic control characteristics, static and dynamic performance, and implementation complexity [2].

II. THE MODEL OF PMSM

The electrical and mechanical equations of the PMSM in the rotor reference (d-q) frame are as follows [7]:

$$\begin{cases} \frac{d}{dt} I_d = -\frac{R_s}{L_d} I_d + \omega_r \frac{L_q}{L_d} I_q + V_d \\ \frac{d}{dt} I_q = -\frac{R_s}{L_q} I_q - \omega_r \frac{L_d}{L_q} I_d - \frac{1}{L_q} \phi_f \omega_r + V_q \end{cases} \quad (1)$$

$$\phi_d = L_d I_d + \phi_f \quad (2)$$

$$\phi_q = L_q I_q \quad (3)$$

And the electromagnetic torque C_e is given by:

$$C_e = \frac{3}{2} P [(L_d - L_q) I_d I_q + I_q \phi_f] \quad (4)$$

The equation for the motor dynamics, on the other hand, is

$$C_e - C_r - C_f = J \frac{d\Omega}{dt} \quad (5)$$

$$\omega = P\Omega \quad (6)$$

Fig. 1 presents the model of PMSM in d-q axis:

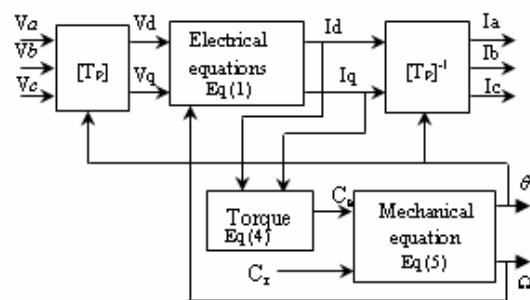

Fig. 1 Functional schema of the Park model

III. DESCRIPTION OF FIELD-ORIENTED CONTROL AND DIRECT TORQUE CONTROLS SCHEMES

A. Field-Oriented Control System

The primary principle in controlling a PMSM drive is based on field orientation. Since the magnetic flux generated from

the PM rotor is fixed in relation to the rotor shaft position, the flux position in the coordinates can be determined by the shaft position sensor. In (2), if $I_d = 0$, the d-axis flux linkage ϕ_d is fixed. Since ϕ_f is constant for a PMSM, the electromagnetic torque is then proportional to I_q which is determined by closed-loop control [8].

$$C_e = \frac{3}{2} P \phi_f I_q \tag{7}$$

Hence the representation follows: [4]

$$C_e = k_t I_q \tag{8}$$

Where:

$$k_t = \frac{3}{2} P \phi_f \tag{9}$$

The rotor flux is produced only in the q axis while the current vector is generated in the axis in the field-oriented control. Since the generated motor torque is linearly proportional to the q-axis current, as the d-axis rotor flux is constant in (2), the maximum torque per ampere can be achieved [3].

Hysteresis PWM Current Control

Hysteresis current control is a PWM technique, very simple to implement and taking care directly for the current control. The switching logic is realized by three hysteresis controllers, one for each phase. Fig. 2

The hysteresis PWM current control, also known as bang-bang control, is done in the three phases separately. Each controller determines the switching-state of one inverter half-bridge in such a way that the corresponding current is maintained within a hysteresis band Δi [9].

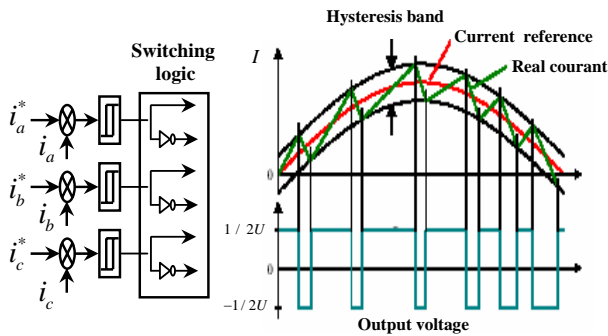

Fig. 2 Hysteresis PWM, current control and switching logic

The configuration of a field-oriented PMSM drive system with conventional cascade position and speed control is shown in Fig. 3.

B. Direct Torque Control system

Since M. Depenbrock and I. Takahashi proposed Direct Torque Control (DTC) for induction machines in the middle of 1980's, more than one decade has passed. It is getting more

and more popular nowadays. The basic idea of DTC for induction motor is to control the torque and flux linkage by selecting the voltage space vectors properly, which is based on the relationship between the slip frequency and torque.

In the late 1990's, DTC techniques for the Permanent Magnet Synchronous Machine (PMSM) machines have appeared [4].

Fig. 4 shows a direct torque controlled PMSM drive system.

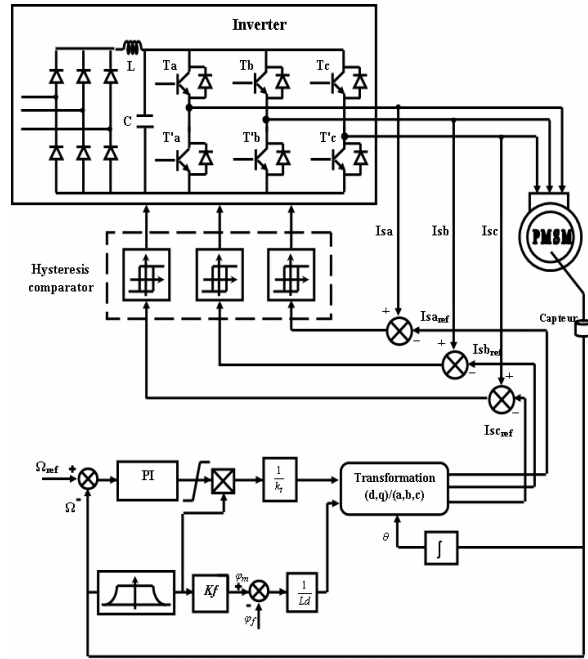

Fig. 3 System configuration of field-oriented PMSM

Estimation of the Torque and the flux Linkage

The basic principle of the DTC is to select proper voltage vectors using a pre-defined switching table.

The selection is based on the hysteresis control of the stator flux linkage and the torque. In the basic form the stator flux linkage is estimated with: [5]

$$\phi_s(t) = \int_0^t (V_s - R_s I_s) dt + \phi_{s0} \tag{10}$$

Where ϕ_0 is the initial value of the stator flux linkage.

Let us replace the estimate of the stator voltage with the true value and write it as:

$$V_s(S_A; S_B; S_C) = \frac{2}{3} U_0 (S_A + S_B e^{j2\pi/3} + S_C e^{j4\pi/3}) \tag{11}$$

S_a, S_b and S_c represent the states of the three phase legs 0 meaning that the phase is connected to the negative and 1 meaning that the phase is connected to the positive leg.

The stator current space vector is calculated from measured currents i_A, i_B, i_C :

$$i_s = \frac{2}{3} (i_A + i_B e^{j2\pi/3} + i_C e^{j4\pi/3}) \quad (12)$$

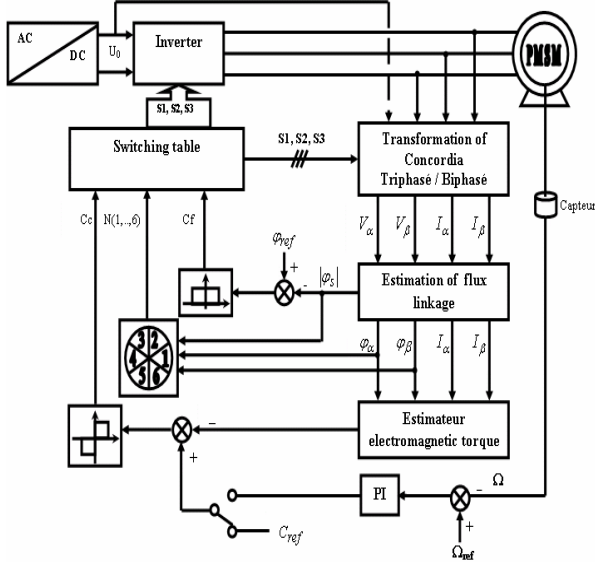

Fig. 4 System diagram of a typical DTC PMSM drive system

5. The voltage vectors obtained this way are shown in Fig. 5.

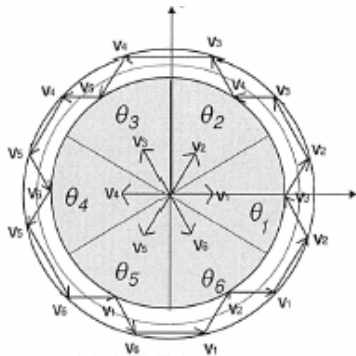

Fig. 5 Voltage vectors for DTC

The composite α and β of vector ϕ_s can be obtained:

$$\begin{cases} \phi_{s\alpha} = \int_0^t (V_{s\alpha} - R_s I_{s\alpha}) dt \\ \phi_{s\beta} = \int_0^t (V_{s\beta} - R_s I_{s\beta}) dt \end{cases} \quad (13)$$

Stator flux linkage written:

$$\phi_s = \sqrt{(\phi_{s\alpha})^2 + (\phi_{s\beta})^2} \quad (14)$$

The angle θ_s is equal to:

$$\theta_s = \arctg \frac{\phi_{s\beta}}{\phi_{s\alpha}} \quad (15)$$

The torque can then be estimated with:

$$C_e = \frac{3}{2} P (\phi_{s\alpha} I_{s\beta} - \phi_{s\beta} I_{s\alpha}) \quad (16)$$

The voltage vector plane is divided into six sectors so that each voltage vector divides each region into two equal parts. In each sector, four of the six non-zero voltage vectors may be used. Also zero sectors are allowed. All the possibilities can be tabulated into a switching table (Table I). The output of the torque hysteresis comparator is denoted as τ , the output of the flux hysteresis comparator as ϕ and the flux linkage sector is denoted as θ .

The torque hysteresis comparator is a three valued comparator. $\tau = -1$ means that the actual value of the torque is above the reference and out of the hysteresis limit, and $\tau = 1$ means that the actual value is below the reference and out of the hysteresis limit. The flux hysteresis comparator is a two valued comparator. $\phi = 0$ means that the actual value of the flux linkage is above the reference and out of the hysteresis limit and $\phi = 1$ means that the actual value of the flux linkage is below the reference and out of the hysteresis limit [6].

TABLE I
SWITCHING TABLE PRESENTED BY TAKAHASHI AND NOGUCHI

θ, τ, ϕ	θ_1	θ_2	θ_3	θ_4	θ_5	θ_6
$\phi = 1$	$\tau = 1$	V_2	V_3	V_4	V_5	V_6
	$\tau = 0$	V_7	V_0	V_7	V_0	V_7
	$\tau = -1$	V_6	V_1	V_2	V_3	V_4
$\phi = 0$	$\tau = 1$	V_3	V_4	V_5	V_6	V_1
	$\tau = 0$	V_0	V_7	V_0	V_7	V_0
	$\tau = -1$	V_5	V_6	V_1	V_2	V_3

IV. COMPARISON OF STATIC AND DYNAMIC PERFORMANCE

In this section, static and dynamic performances of FOC and DTC schemes are obtained by simulation using the MATLAB/ Simulink Power System Blockset.

Since the objective of the work is to compare the control strategies, the same power section is used in both systems.

It is necessary to make a comparison of static and dynamic characteristics of both technical command and under the same operating conditions (reference, charges disturbance... etc.), and in the same configuration simulation (step sampling, time simulation,)

In this paper we will present the advantages and disadvantages of each type of command, better command will be the one that best meets the requirement to know:

- Best performance static and dynamic.
- Best prosecution guidelines control.

- Best releases disturbance.
- Insensitivity to changes in parameters.

A. Comparison at the level of regulation speed

Fig. 6 illustrates the simulation results of both technical command FOC hysteresis and the DTC, where to apply a torque load equal to 5N.m at $t = 0.1s$ and a reference speed equal to 100 rad /s.

It is noted that the FOC hysteresis presents a peak torque at startup larger than the DTC, and a torque of quick response due to application of the load at $t = 0.1s$, which allows the rapid rejection of the disturbance.

At speed, we can see that the DTC has a high dynamic without overshoot, start-up, and the response time are reduced compared to the FOC hysteresis.

For the answer stator flux, it reaches its reference value without overrun for the DTC, against the FOC hysteresis there is an overrun at startup.

B. Test of Strength for Reversing Rotation of the Machine

To test the robustness of both technical command at the reverse direction of rotation, it introduced a change in record speed reference +100 rad/s to -100 rad /s time $t=0.1s$ after a torque load equal to 3 Nm. In Fig. 7, we can say that the continuation in speed is normally and without overrun for both technical commands (DTC and FOC). It notes that the FOC hysteresis presents a peak torque than the DTC.

C. Test of Robustness for Load Change

Fig. 8 represents speed, torque and Flux stator of the machine in case starter vacuum and a level of speed equal to 100rad /s.

At the moment $t = 0.1s$ she applies a load torque equal to 5N.m, then at $t = 0.15s$ applying a load torque equal to 0N.m, we find that the Torque responds instantly, and that its speed reaches Reference after a small deformation in the case of FOC. By cons in the case of DTC speed reaches its reference after a considerable strain. The trajectory of the flux in (α, β) reference is circular.

V. COMPARISON BETWEEN THE DTC AND THE FOC

The DTC does not necessitate any mechanical measure such as the one of speed or position of the machine; of more the sensitiveness to the machine parameters clearly is lessened in the case of the DTC, since the flow estimation is done according to a single parameter to know the resistance stator.

In addition, PWM is replaced, in this order by a simple table of commutation which the return, so much easier.

The order DTC has for advantages:

- The reduction of the time of response of the couple.
- The hardness in comparison with the variation of the parameters of the machine and nutrition.
- The direct imposition of the amplitude of the undulations of the couple and flow.
- She adapts herself by nature to the absence of sensor

Mechanical connected to the tree motor. She presents major problems:

- The absence of mastery of the harmonic ones of couple.

The check vector by orientation of the flux rotorique FOC was developed to eliminate internal coupling of the machine, provoking variations of the flux linkage to the Torque.

The control vector by orientation of the flux rotorique presents a number of advantages:

- To allow a decouplage between the flux and the torque rather simple, thus a wide beach of speed.

And a number of inconveniences:

- Weak hardness to the variations Parametric and in particular to the one of the constant one of time rotorique.
- Necessitated of a modulation one for the order come close to the inverter that provokes delays, especially down with frequency of modulation.

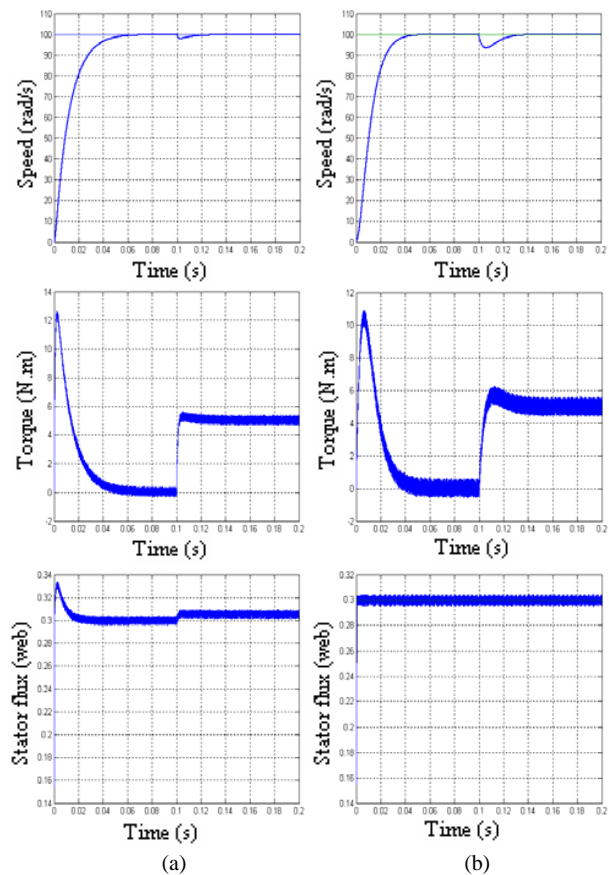
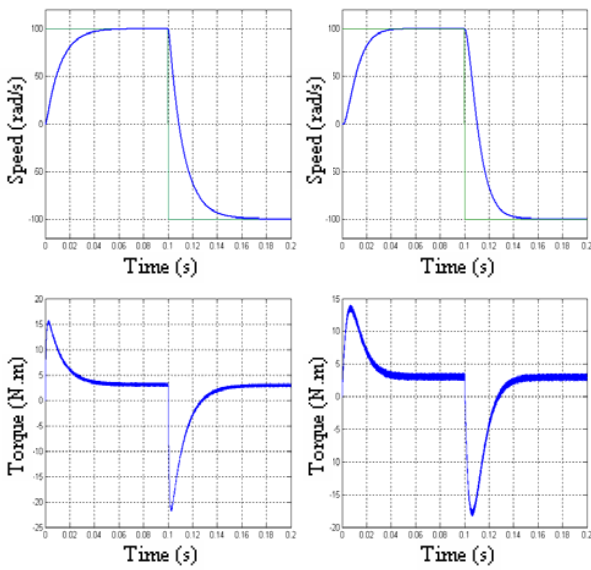
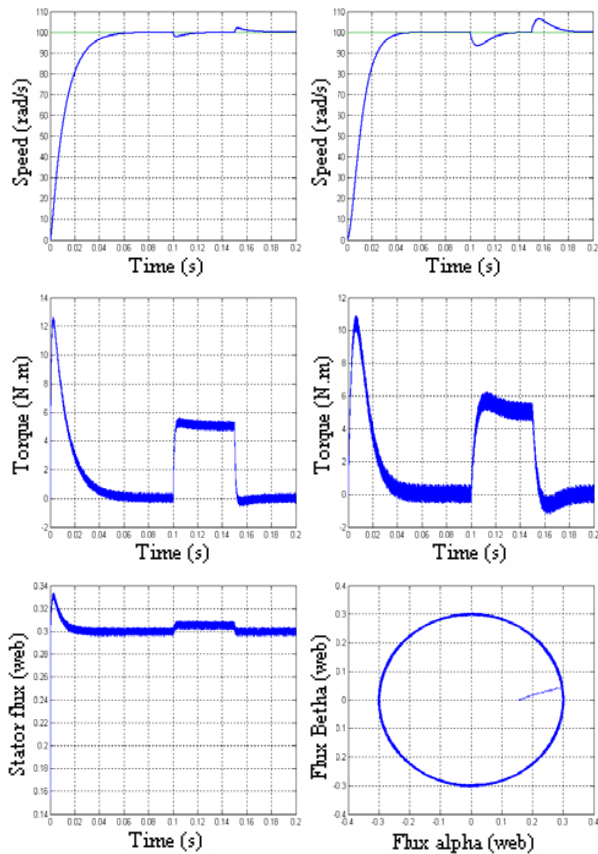

Fig. 6 Regulation of speed followed by an application of torque load at the $t = 0.1 s$



(a) FOC (b) DTC
Fig. 7 Comparison of inversion speed (100rad/s, -100 rad/s)



(a) FOC (b) DTC
Fig. 8 Comparison at the variation torque load

Table II, summary a comparative study of the performances between the order FOC and the DTC:

TABLE II
COMPARISON OF FOC AND DTC SCHEMES

	FOC	DTC
Transformation	Present	Void
Dynamics	high	high
Robustness	Robust	Robust
Speed sensor	Necessary	Less necessary
Parameter sensitivity	Big	Average
Control close	Necessary PWM	Not of PWM
Découplage	Necessitate orientation	Natural
Regulators	Three stator regulator (Hysteresis)	- Torque regulator - Flux regulator
Behavior down speed	Good	not good

TABLE III
PARAMETERS OF THE PMSM USED IN THIS PAPER

Rated output power	1500 Wat
Magnetic flux linkage	0.154 web
Poles	3
Stator resistance	1.4 Ω
q-axis inductance	0.0058 H
d-axis inductance	0.0066 H
Inertia	0.00176 KG.M ²
friction Coefficient	0.00038 N.M.S/ rad

VI. CONCLUSION

In this paper, main characteristics of field-oriented and direct torque control schemes for PMSM drives are studied by simulation with a view to highlighting the advantages and disadvantages of each approach. It is difficult to clearly state on the superiority of DTC versus FOC because of the balance of the merits of the two schemes.

We one conclude that the vector order it better is adapted (load variation), and the responses with the DTC are quicker.

REFERENCES

- [1] C. Mademlis, V. G. Agelidis, "On Considering Magnetic Saturation with Maximum Torque to Current Control in Interior Permanent Magnet Synchronous Motor Drives," IEEE Trans. Energy Conversion, vol. 16, no. 3, Sep. 2001.
- [2] H. L. Huy, "Comparison of Field-Oriented Control and Direct Torque Control for Induction Motor Drives," 0-7803-5589-X/99/\$10.00 © 1999 IEEE.
- [3] K. K. Shyu, C. K. Lai, Y. W. Tsai, and D. I. Yang, "A Newly Robust Controller Design for the Position Control of Permanent-Magnet Synchronous Motor," IEEE Trans on Industrial Electronics. vol. 49, no. 3, Jun. 2002.
- [4] L. Tang, L. Zhong, M. F. Rahman and Y. Hu, "A Novel Direct Torque Control for Interior Permanent Magnet Synchronous Machine Drive System with Low Ripple in Torque and Flux-A Speed Sensorless Approach" 0-7803-7420-7/02/\$17.00 © 2002 IEEE.
- [5] M. F. Rahman, L. Zhong, E. Haque, and M. A. Rahman, "A Direct Torque-Controlled Interior Permanent-Magnet Synchronous Motor

- Drive Without a Speed Sensor " IEEE Trans. Energy conversion, vol. 18, no. 1, Mar. 2003.
- [6] J. Luukko "Direct torque control of permanent magnet synchronous machines analysis and Implementation" Lappeenranta 2000.
- [7] P. Pragasan, and R. Krishnan, "Modeling of permanent magnet motor drives" IEEE Trans. Industrial electronics, vol. 35, no.4, nov. 1988.
- [8] G. Grellet et G. Clerc, "Actuators electric Principe / model / control ". Eyrolles,(2nd ed.) 2000, pp. 298-300.
- [9] F. Labrique, H. buyse, G. seguier and R. Bausière, "Converters power electronics command and dynamic behavior " vol. 5, 1998, pp. 68-73.