

Comparative Exergy Analysis of Ammonia-Water Rankine Cycles and Kalina Cycle

Kyoung Hoon Kim

Abstract—This paper presents a comparative exergy analysis of ammonia-water Rankine cycles with and without regeneration and Kalina cycle for recovery of low-temperature heat source. Special attention is paid to the effect of system parameters such as ammonia mass fraction and turbine inlet pressure on the exergetical performance of the systems. Results show that maximum exergy efficiency can be obtained in the regenerative Rankine cycle for high turbine inlet pressures. However, Kalina cycle shows better exergy efficiency for low turbine inlet pressures, and the optimum ammonia mass fractions of Kalina cycle are lower than Rankine cycles.

Keywords—Ammonia-water, Rankine cycle, Kalina cycle, exergy, exergy destruction, low-temperature heat source.

I. INTRODUCTION

RECENTLY the importance of thermodynamic cycles which convert low-temperature heat sources to useful energies has been attracting much attention due to exhaustion of fossil fuel and environmental problems [1]-[3]. Typical low-temperature heat sources include solar, geothermal, marine energy, bio-energy, and industrial waste heat. Even in the case of internal combustion engines, about 60% of the chemical energy of the fuel is released in the form of sensible energy through exhaust gas, cooling water and lubricating oil [4].

The most competitive systems for efficient conversion of low-temperature heat sources are the Rankine cycle and the Kalina cycle using ammonia-water mixture as the working fluid. Using a zeotropic mixture like ammonia-water mixture instead of a pure substance as a working fluid results in the phase change with wide range of temperature, thus reducing temperature mismatch between the sensible heat source fluid and working fluid in a heat exchanger and reducing exergy destruction. Therefore, the cycles have a lot of advantages in power generation for recovery of low-temperature heat sources [5], [6]. The Kalina cycle is based on the Rankine cycle and separates the vapor and liquid after heating the working fluid so that the high concentration steam is expanded in the turbine to produce power, then mixed with the low concentration liquid and condensed in the condenser. These Kalina cycles have shown excellent potential for the conversion of low grade heat sources and are in the process of commercialization worldwide [7], [8].

Kim et al. [9], [10] analyzed the performance characteristics of the system energy and exergy with and without regenerator in the ammonia-water Rankine cycle using low-temperature

heat sources and analyzed the performance characteristics of ammonia-water mixture heat exchanger. The pinch point characteristics were reported in [11]. Lolos and Rogdakis [12] analyzed the performance of a Kalina cycle with solar heat as a heat source, and Ogriseck [13] investigated the case of Kalina power generation in Germany. Yue et al. [14] compared and analyzed the performance of Kalina Cycle and Transient Transcritical Organic Rankine Cycle in the cryogenic cogeneration system.

The Kalina cycle process is a modified Clausius Rankine process and the basic solution in a Kalina plant is a binary fluid with a certain ratio of water and ammonia. For the design of a Kalina cycle, an optimum between heat exchanger surface and the generated electricity has to be found. This optimum is influenced by different parameters such as the temperature level at the condenser, ammonia mass fraction in the binary fluid, turbine inlet pressure, and the temperature of heat source [15]. KCS-11 is a well-known Kalina cycle for low-temperature driven power generation and using ammonia-water as its working fluid for this purpose. Many researchers tried their best to clear the characteristics of the KCS-11 for using various forms of low-temperature heat sources [16].

However, comparative exergetical studies on ammonia-water Rankine cycles and Kalina cycle have not been found in the literature so far. In this study, the exergetical performance of the ammonia-water Rankine cycles with and without regeneration and the Kalina cycle (KCS-11) are compared for the recovery of low-temperature heat source in the form of sensible energy. The exergetical performance characteristics of the system according to the change of ammonia fraction or turbine inlet pressure of the mixture are analyzed.

II. SYSTEM ANALYSIS

In this study, comparative exergetical analysis is carried out for basic ammonia-water Rankine Cycle (AWB), regenerative ammonia-water Rankine cycle (AWR), and Kalina Cycle System (KCS) for recovery of low-temperature heat source in the form of sensible energy as shown in Fig. 1. The system of the regenerative Rankine cycle (AWR) is operated as follows [6], [7]. The working fluid in the bubble-point state leaving the condenser (state 1) is pressurized by the pump (state 2) and preheated by the regenerator (state 3). Then, the fluid enters the heat exchanger and is heated to the superheated vapor state by the source fluid and enters the turbine (state 4). The working fluid expands in the turbine (state 5) with producing mechanical work. The fluid then enters the regenerator and preheats the working fluid and enters the condenser (state 6). The system of the Kalina cycle is as follows. The working fluid leaves the

K. H. Kim is with the Department of Mechanical Engineering, Kumoh National Institute of Technology, Gyeongsangbuk 39177 Korea (phone: 82-54-478-7292; fax: 82-54-478-7319; e-mail: khkim@kumoh.ac.kr).

condenser in the bubble-point state (state 1) and is pressurized by the pump (state 2), preheated through the regenerator (state 3), then enters the heat exchanger and is heated to a state of saturated vapor and liquid mixture (state 4) and enter the separator. The steam leaving the separator (state 5) expands in the turbine to state 6 with producing mechanical power. On the other hand, the liquid leaving the separator (state 7) preheats the pressurized liquid by the pump (state 8), is throttled (state 9) and enters the condenser (state 10) with the vapor leaving the turbine (state 10).

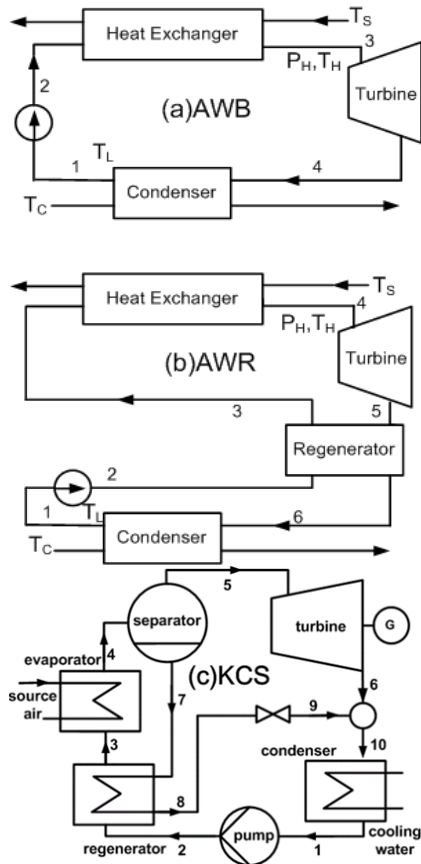

Fig. 1 Schematic diagrams of (a)AWB, (b)AWR, and (c) KCS

In this study, the following assumptions are made for interpretation [7]. The system ignores the pressure drop except for the pump or turbine, ignores the heat loss except the heat exchanger and assumes constant isentropic efficiency in the pump and turbine. It is assumed that the working fluid at the turbine inlet of the primary and regenerative Rankine cycles is pure vapor and that the working fluid quality at the turbine outlet should be at least 90% of the reference value and that in the Kalina cycle the working fluid at the evaporator outlet should be a vapor-liquid mixture. The pinch temperature difference, ΔT_{pp} , is prescribed so that

$$\min(T_{hot} - T_{cold}) = \Delta T_{pp} \quad (1)$$

This assumption means that the flow rate of the working

fluid is maximized for a given heat source fluid in a heat exchanger and the flow rate of cooling water is minimized for a given working fluid in a condenser.

In the case of a regenerative Rankine cycle in three cycles, the main parameters of the system can be obtained as follows. If the flow rate, specific heat and inlet/outlet temperature of the heat source fluid are m_s , c_{ps} , T_s , T_{sout} , respectively, the flow rate m_w of the working fluid is obtained from the energy balance in the heat exchanger as follows;

$$m_w = \frac{m_s c_{ps} (T_s - T_{sout})}{h_4 - h_3} \quad (2)$$

where h is the specific enthalpy of the working fluid. Let Q_{in} , Q_r , W_{net} be the inlet heat of the system, the heat transfer of the regenerator, the date of production of the ash, the net output and the thermal efficiency, respectively.

$$Q_{in} = m_w (h_4 - h_3) \quad (3)$$

$$Q_r = m_w (h_3 - h_2) \quad (4)$$

$$W_{net} = m_w (h_4 - h_5 + h_1 - h_2) \quad (5)$$

The exergy efficiency is defined as the ratio of the network to the exergy input [10], [17]:

$$\eta_{ex} = \frac{W_{net}}{E_{in}} \quad (6)$$

The exergy destruction or anergy of the adiabatic system is calculated as the difference of exergy input and output. The exergy destruction ratio at a system component is defined as the ratio of anergy there to the exergy input by source fluid. Then summation of all anergy ratios of the system and the exergy efficiency becomes unity [18]:

$$\eta_{ex} + D_s + D_{sout} + D_c + D_{cout} + D_r + D_w = 1 \quad (7)$$

where D_s , D_{sout} , D_c , D_{cout} , D_r , and D_w are exergy destruction ratio of the source heat exchanger, source exhaust, condenser, coolant exhaust, regenerator, and power production, respectively.

The thermodynamic properties of ammonia-water mixture are evaluated using the method of Gibbs free energy which was first introduced by Xu and Goswami [19], and the equilibrium conditions are determined by equating the chemical potentials of each phase for each element [9].

$$\mu_a^L = \left(\frac{\partial G_m^L}{\partial N_a} \right)_{T,P,N_w} = \left(\frac{\partial G_m^g}{\partial N_a} \right)_{T,P,N_w} = \mu_a^g \quad (8)$$

$$\mu_w^L = \left(\frac{\partial G_m^L}{\partial N_w} \right)_{T,P,N_a} = \left(\frac{\partial G_m^g}{\partial N_w} \right)_{T,P,N_a} = \mu_w^g \quad (9)$$

Here, N_a , N_w , and N are the numbers of moles of ammonia, water, and the mixture, respectively. The Gibbs free energy of

G_m for liquid or gas phase is denoted as

$$G_m = N_a[G_a + RT \ln x] + N_w[G_w + RT \ln(1-x)] + NG^E \quad (10)$$

III. RESULTS AND DISCUSSIONS

In this work, it is considered that the source fluid is air at $T_S = 180^\circ\text{C}$ with mass flow rate 1 kg/s. The basic data of the system variables are as follows; turbine inlet temperature $T_H = 160^\circ\text{C}$, condensation temperature $T_C = 25^\circ\text{C}$, coolant temperature $T_L = 15^\circ\text{C}$, pinch temperature difference $\Delta T_{pp} = 5^\circ\text{C}$, isentropic pump efficiency $\eta_p = 0.85$, isentropic expander efficiency $\eta_i = 0.90$, respectively.

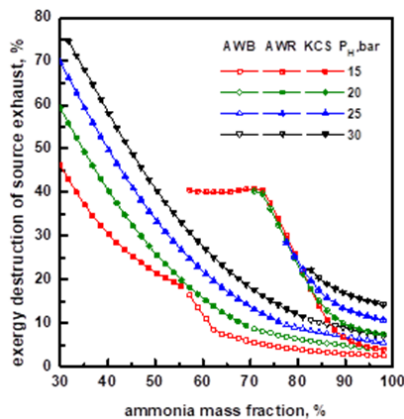

Fig. 2 Effect of ammonia mass fraction on the exergy destruction ratio of source exhaust

Fig. 2 illustrates the effects of ammonia mass fraction on the exergy destruction ratio of source exhaust, D_{so} . In AWB, the ratio decreases with increasing pressure, since the evaporation temperature decreases and consequently the exit temperature becomes lower. In AWR, the ratio increases with increasing ammonia mass fraction when the turbine inlet pressure is 15 bar and ammonia mass fraction is lower than 73%. But, for other conditions, the ratio decreases with increasing ammonia mass fraction due to the decreased evaporation temperature. In KCS, as the ammonia mass fraction increases, the ratio decreases for all turbine inlet pressures. When the turbine inlet pressure becomes higher for a specified ammonia mass fraction; however, the effect of increase in the bubble point temperature becomes dominant, which leads to a higher exit temperature of source temperature and consequently to a higher exergy destruction ratio in all cycles.

Fig. 3 shows the effects of ammonia mass fraction on the exergy destruction ratio of the heat exchanger, D_h . In AWB and AWR, the ratio becomes higher for higher ammonia mass fractions, since the heat addition from the source heat exchanger increases as the ammonia mass fraction becomes higher. It can be seen from the figure the ratio of AWB is higher than AWR for a specified ammonia mass fraction, since the heat transfer in AWB is higher than AWR preheated by regenerator. In KCS, the ratio increases also with increasing ammonia mass fraction, because as the ammonia mass fraction

increases, the heat addition with source heat exchanger increases and the mismatch between hot and cold streams in the heat exchanger becomes higher. In all cycles, the ratio decreases with increase in the pressure due to decreasing heat transfer in the heat exchanger. It is to be noted that the ratios of KCS are much lower than those in AWB.

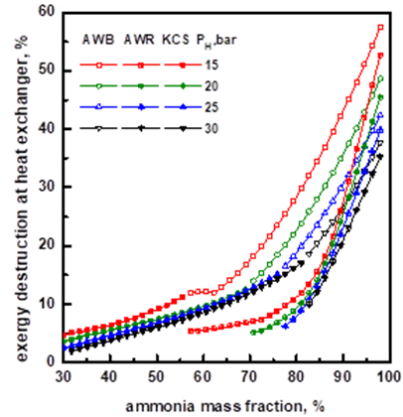

Fig. 3 Effect of ammonia mass fraction on the exergy destruction ratio at source heat exchanger

Fig. 4 displays how the exergy destruction ratio of the coolant exhaust, D_{co} , is affected by the ammonia mass fraction. It can be observed from the figure that as the ammonia mass fraction increases, the exergy destruction ratio the exergy destruction ratio drops in AWB but increases in KCS. However, the ratio decreases with increasing for a given ammonia mass fraction in both AWB and KCS. In AWR, however, as the ammonia mass fraction increases, the ratio firstly decreases and then increases, and finally decreases again, so it shows a complex behavior. It is to be noted that the exergy destruction ratios in AWR are much lower than AWB. For a specified ammonia mass fraction, the ratio decreases with increasing turbine inlet pressure in AWB and KCS.

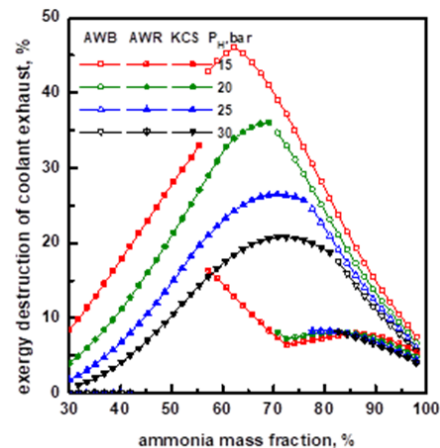

Fig. 4 Effect of ammonia mass fraction on the exergy destruction ratio of coolant exhaust

Fig. 5 shows how the exergy destruction ratio of the

condenser, D_c , is affected by the ammonia mass fraction. In AWB, as the ammonia mass fraction increases, the ratio firstly increases and reaches a local maximum value and then decreases again. In AWR and KCS, however, the ratio firstly increases and reaches a local maximum value and then decreases, and finally increases again, so it shows a complex behavior. It is to be noted that the ratio in AWB is much higher than in AWR and KCS. As turbine inlet pressure increases, the exergy destruction ratio decreases in AWB and KCS, but increases in AWR for a given ammonia mass fraction.

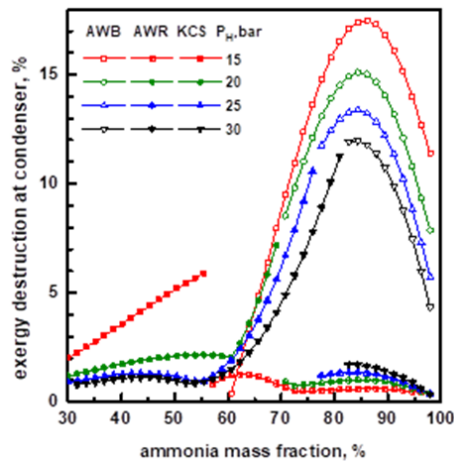

Fig. 5 Effect of ammonia mass fraction on the exergy destruction ratio at condenser

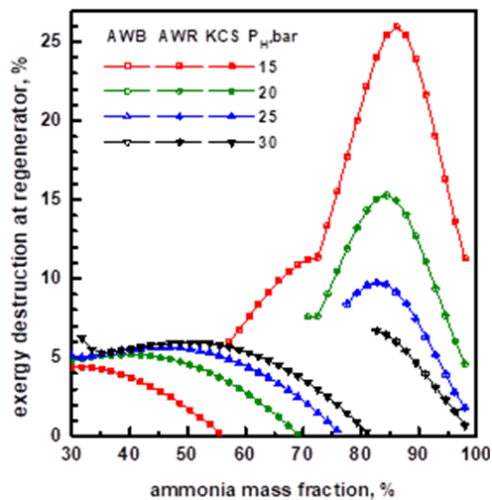

Fig. 6 Effect of ammonia mass fraction on the exergy destruction ratio at regenerator

Fig. 6 illustrates the effects of the ammonia mass fraction on the exergy destruction ratio at regenerator. In AWR, as the ammonia mass fraction increases, the exergy destruction ratio firstly increases and reaches a local maximum value and then decreases again. When the turbine inlet pressure is 15 bar, the exergy destruction ratio has a peak value of 26% at ammonia mass fraction of 87%. As the turbine inlet pressure increases,

each of the maximum exergy destruction ratio and the corresponding ammonia mass fraction decreases. It is to be noted that the lower limit of ammonia mass fraction for proper operation decreases with increasing turbine inlet pressure. In KCS, however, the ratio firstly increases and reaches a local maximum value as ammonia mass fraction increases.

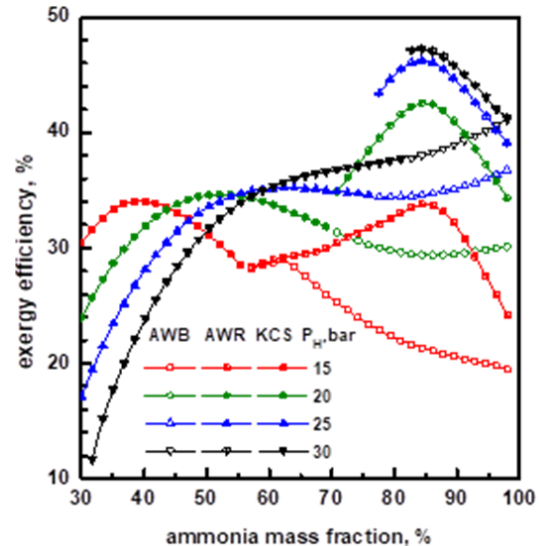

Fig. 7 Effect of ammonia mass fraction on the exergy destruction ratio of exergy efficiency

Fig. 7 shows the effects of the ammonia mass fraction on the exergy efficiency which is defined as the ratio of the net power production to the exergy input into the system. AWB shows different behavior of the exergy efficiency depending on the turbine inlet pressure. As the ammonia mass fraction increases, the exergy efficiency monotonically decreases for $P_H = 15$ bar, has a local minimum value for $P_H = 20$ bar, but monotonically increases for $P_H = 25$ bar and 30 bar. In AWR, the exergy efficiency has a maximum value with respect to ammonia mass fraction. As the turbine inlet pressure increases, the maximum value increases while the corresponding optimum ammonia mass fraction slightly decreases. In KCS, the exergy efficiency has a maximum value with respect to the ammonia mass fraction, and the maximum efficiency and the corresponding optimum ammonia mass fraction increases as the turbine inlet pressure increases. When the turbine inlet pressure is 30 bar, the exergy efficiency monotonically increases with increasing ammonia mass fraction. It is to be noted the optimum ammonia mass fractions in KCS are much lower than AWR, and the maximum exergy efficiencies in AWR are higher than those in AWB or KCS.

IV. CONCLUSION

The exergetical performance characteristics of the basic Rankine cycle, the regenerated Rankine cycle and the Kalina cycle using the ammonia - water mixture as the working fluid for recovery of low-temperature heat source were compared and analyzed.

The important conclusions are as follows:

- 1) For effective operation of the system, the basic and regenerative Rankine cycles have a lower limit while the Kalina cycle has an upper limit of the ammonia fraction. The limits of the ammonia mass fraction increase as the turbine inlet pressure increases.
- 2) The thermal efficiency of the system can have a peak value with respect to the ammonia mass fraction, and the Kalina cycle is the best and the basic Rankine cycle is the lowest at the same operating conditions.
- 3) The exergy efficiency of the system can have a peak value with respect to the ammonia mass fraction. The exergy efficiency of the regenerated Rankine cycle is the best under the same operating conditions.
- 4) The optimal ammonia mass fractions for the maximum exergy and thermal efficiencies of the Kalina cycle are much lower than the regenerated Rankine cycle.

ACKNOWLEDGMENT

This research was supported by Basic Science Research Program through the National Research Foundation of Korea (NRF) funded by the Ministry of Education, Science and Technology (No. 2016935888).

REFERENCES

- [1] S. H. J. Bao and L. Zhao, "A review of working fluid and expander selections for organic Rankine cycle", *Renew. Sustain. Energy Rev.*, vol. 24, pp. 325-342, 2013.
- [2] V. A. Prisyazhniuk, "Alternative trends in development of thermal power plant", *Applied Therm. Eng.*, vol. 28, pp. 190-194, 2008.
- [3] K. H. Kim, H. J. Ko, and S. W. Kim, "Performance Analysis of Kalina Cycle using Ammonia-Water Mixture as Working Fluid for Use of Low-Temperature Energy Source", *Trans. Korean Hydrogen and New Energy Society*, vol. 22, pp. 109-117, 2011.
- [4] C. Yu and K. T. Chau, "Thermoelectric automotive waste heat energy recovery using maximum power point tracking", *Energy Convers Manage*, vol. 50, pp. 1506-1512, 2009.
- [5] P. Roy, M. Desilets, N. Galanis, H. Nesreddine H., and E. Cayer, "Thermodynamic analysis of a power cycle using a low-temperature source and a binary NH₃-H₂O mixture as working fluid", *Int. J. Thermal Sci.*, vol. 49, pp. 48-58, 2010.
- [6] K. H. Kim and C. H. Han, "Performance Analysis of Ammonia-Water Regenerative Rankine Cycles for Use of Low-Temperature Energy Source", *J. Korean Solar Energy Soc.*, vol. 31, pp. 15-22, 2011.
- [7] R. Shankar and T. Srinivas, "Performance investigation of Kalina cooling cogeneration cycles," *Int. J. Refrigeration*, vol. 86, pp. 163-185, 2018.
- [8] S. Zhang, Y. Chen, J. Wu, and Z. Zhu, "Thermodynamic analysis on a modified Kalina cycle with parallel cogeneration of power and refrigeration," *Energy Conv. Management*, vol. 163, pp. 1-127, 2018.
- [9] K. H. Kim, C. H. Han, K. Kim, "Effects of Ammonia Concentration on the Thermodynamic Performances of Ammonia-Water Based Power Cycles", *Thermochimica Acta*, vol. 530, pp. 7-16, 2012.
- [10] K. H. Kim, C. H. Han, and K. Kim, "Comparative exergy analysis of ammonia-water based Rankine cycles with and without regeneration", *Int. J. Exergy*, vol. 12, pp. 344-361, 2013.
- [11] K. H. Kim, H. J. Ko, and K. Kim, "Assessment of pinch point characteristics in heat exchangers and condensers of ammonia-water based power cycles", *Applied Energy*, vol. 113, pp. 970-981, 2014.
- [12] P. A. Lolos and E. D. Rogdakis, "A Kalina power cycle driven by renewable energy sources", *Energy*, vol. 34, pp. 457-464, 2009.
- [13] S. Ogriseck, "Integration of Kalina cycle in a combined heat and power plant, a case study", *Applied Ther. Eng.*, vol. 29, pp. 2843-2848, 2009.
- [14] C. Yue, D. Han, W. Pu, and W. He, "Comparative analysis of a bottoming transcritical ORC and a Kalina cycle for engine exhaust heat recovery", *Energy Convers Manage.*, vol. 89, pp. 764-774, 2015.
- [15] A. Modi, F. Haglind, "Thermodynamic optimisation and analysis of four Kalina cycle layouts for high temperature applications," *App. Therm. Eng.*, vol. 76, pp. 196-205, 2015
- [16] F. Sun, W. Zhou, Y. Ikegami, K. Nakagami, and X. Su, "Energy-exergy analysis and optimization of the solar-boosted Kalina cycle of the solar-boosted Kalina cycle system 11 (KCS-11)," *Renewable Energy*, vol. 66, pp. 268-279, 2014.
- [17] A. Bejan, *Advanced Engineering Thermodynamics*, 3rd ed. New York, NY, USA: John Wiley & Sons, 2006
- [18] K. H. Kim, C.H. Han, K. Kim, "Comparative exergy analysis of ammonia-water based Rankine cycles with and without regeneration," *Int. J. Exergy*, Vol. 12, pp. 344-361, 2013.
- [19] F. Xu and D. Y. Goswami, "Thermodynamic properties of ammonia-water mixtures for power cycle," *Energy*, vol. 24, pp. 525-536, 1999.