

Comparative Dielectric Properties of 1,2-Dichloroethane with n-Methylformamide and n,n-Dimethylformamide Using Time Domain Reflectometry Technique in Microwave Frequency

Shagufta Tabassum, V. P. Pawar, jr., G. N. Shinde

Abstract—The study of dielectric relaxation properties of polar liquids in the binary mixture has been carried out at 10, 15, 20 and 25 °C temperatures for 11 different concentrations using time domain reflectometry technique. The dielectric properties of a solute-solvent mixture of polar liquids in the frequency range of 10 MHz to 30 GHz gives the information regarding formation of monomers and multimers and also an interaction between the molecules of the liquid mixture under study. The dielectric parameters have been obtained by the least squares fit method using the Debye equation characterized by a single relaxation time without relaxation time distribution.

Keywords—Excess properties, relaxation time, static dielectric constant, time domain reflectometry technique.

I. INTRODUCTION

THE dielectric relaxation study of polar liquid mixture in the microwave frequency range gives the information about formation of monomers and multimers, kinematics, dynamics and also the interaction between the molecules of the binary liquid mixture [1]-[3]. The interaction of electromagnetic radiation with the dielectric liquid mixture gives a complex quantity, in which real part indicates the static dielectric constant (ϵ') and the imaginary part (ϵ'') represents the dielectric loss.

1,2-dichloroethane (DE) is a polar and aprotic solvent liquid, which is slightly soluble in water. It is a sticky, colorless and heavily non associative liquid. It is an important chemical liquid which is very useful for production of various chemicals such as vinyl chloride, used as a wetting and penetrating agent for dispersion of rubber and plastics, used in chemical industries as in ore flotation, as a grain fumigant, as a metal degreaser, in textile and PVC cleaning [4].

N-methylformamide (NMF) is a colorless, odorless, organic component. It is mainly used as a reagent in various

organic syntheses [5].

The n,n-dimethylformamide (DMF) is a polar aprotic solvent. It is a colorless liquid with high boiling point and is miscible with water and the majority of organic liquids. It is used as an industrial solvent in chemical industries and also in the production of fibers, films and surface coating [6].

DE and amides (NMF & DMF) have high polarity, strong solvating power, and a large liquid range, which makes them industrial and technological important solvents. The DE, NMF and DMF linkages (-CH₂-Cl), (-NH-CH=O) and (NH-C=O) respectively, are an important functional groups in chemistry, biochemistry, pharmaceutical, and material science [7].

The effect of the chlorine group molecule of DE in the C=O functional group of amides mixture gives very important information. The main object of this paper is to give complex, static dielectric properties and excess properties of DE-amides liquid mixture.

II. EXPERIMENTAL TECHNIQUE

A. Materials

DE (AR Qualigens fine chemicals Pvt. Ltd., Mumbai, India), NMF and DMF (Merck Specialties, Pvt. Ltd., Mumbai, India) polar binary liquids are used without further purification. The liquid mixture is prepared at 11 different volume percent by decreasing the liquid 1 (DE) from 100% to 0% and increasing the liquid 2 (NMF or DMF) from 0% to 100% just before the measurement. Using these volume percent the mole fraction is calculated as

$$x = \{(v_1 \rho_1 / m_1) / [v_1 \rho_1 / m_1 + v_2 \rho_2 / m_2]\} \quad (1)$$

where m_i , v_i , and ρ_i represent the molecular weight, volume percent and density of the i^{th} ($i=1, 2$) liquids, respectively.

B. Apparatus

The "Time Domain Reflectometry" (TDR) is a technique of observing the time-dependent reflection response of the time-dependent electromagnetic signal from the sample under study. TDR technique is used to obtain complex permittivity spectra of binary liquids [4]-[8]. The TDR dielectric measurement system composed of a step generator induces a fast rising step pulse of the order of picoseconds, DSA8200 Digital Serial Analyzer is a high-speed, precision sampling

Shagufta Tabassum is a Research Scholar, Department of Physics & Electronics, Maharashtra Udayagiri Mahavidyalaya, Udgir-413 517, Latur, Maharashtra, India (phone: +91-90306-00508; e-mail: tabassum.sagufta@gmail.com).

V. P. Pawar, Jr., is a Professor, Department of Physics, Sunderrao Solanke Mahavidyalaya, Majalgaon- 431 131, Beed, Maharashtra, India (e-mail: pawar_vyankat@yahoo.com).

G. N. Shinde is a Professor, Department of Physics & Electronics, Yeshwanth Mahavidyalaya, Nanded-431 602, Maharashtra, India (e-mail: shindegn@yahoo.co.in).

system, TDR/sampling module 80E08 contains two oscilloscope measurement channels and a sample cell. The step generator produces a fast rising pulse of the order of picoseconds. A train of suitable fast rising pulses is applied to a transmission line, usually a coaxial line with the characteristic impedance of 50Ω . A coaxial line is connected to the sampling device (sample holder). The schematic diagram of the experimental setup for TDR [9], [10] is shown in Fig. 1.

Fig. 2 represents the sampling oscilloscope, which will record the change in the incident pulse after reflection from the sample holder. The reflected pulse without sample $R_1(t)$ and with sample $R_x(t)$ were recorded in the time window of 5 ns and digitized in 2000 points as shown in Fig. 3. The controller system of a water bath is used to maintain a constant temperature around the liquid cell and a thermostatically maintained temperature within $\pm 0.5 \text{ }^\circ\text{C}$. A heat insulating container through which the constant temperature water was circulated is covered around the sample cell. By using electronic thermometer the temperature

of sample cell was measured.

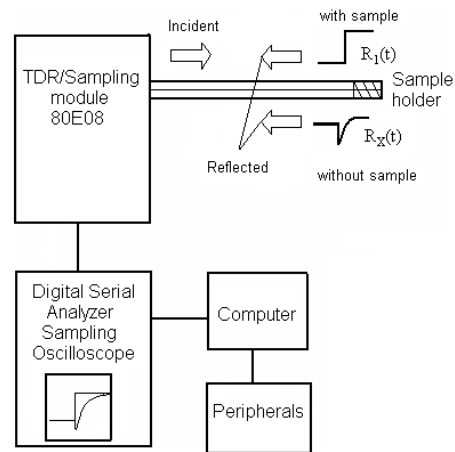

Fig. 1 Block diagram of TDR setup

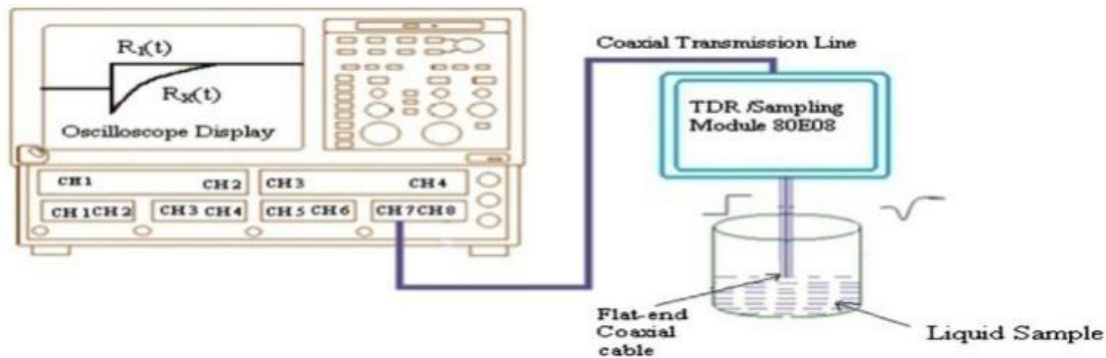

Fig. 2 Tektronix DSA8200 digital serial analyzer sampling oscilloscope

III. DATA ANALYSIS

The nature of the pulses without and with the sample is observed. This time-dependent data were simplified to obtained reflection coefficient spectra $\rho^*(\omega)$ over the microwave frequency range using Fourier transformation as [11], [12]:

$$\rho^*(\omega) = c/j\omega d [p(\omega)/q(\omega)] \quad (2)$$

where $p(\omega)$ and $q(\omega)$ are Fourier transforms of $[R_1(t) - R_x(t)]$ and $[R_1(t) + R_x(t)]$ respectively are shown in Figs. 3 and 4, c is the velocity of light, ω is angular frequency, d is the effective pin length and $j = \sqrt{-1}$.

By using bilinear calibration [13] method, the complex permittivity spectra $\varepsilon^*(\omega)$ were obtained from reflection coefficient spectra $\rho^*(\omega)$.

$$\varepsilon^*(\omega) = \varepsilon_\infty + \frac{(\varepsilon_0 - \varepsilon_\infty)}{[1 + (j\omega\tau)^{(1-\alpha)}]^\beta} \quad (3)$$

where $\varepsilon^*(\omega)$ is the complex permittivity at an angular frequency ω , ε_0 is the static permittivity, ε_∞ is the permittivity at high frequency, τ is the relaxation time of the system, α is the shape parameter representing the symmetrical distribution of relaxation time and β is the shape parameter of an asymmetric relaxation curve.

The values of α and β lie within 0 to 1. These values indicate the type of distribution of relaxation time curve. For the Debye model [14], $\alpha = 0$ & $\beta = 1$. It shows the single relaxation time curve whereas the Cole-Cole [15] represents the symmetric distribution of relaxation time curve ($0 \leq \alpha \leq 1$ & $\beta = 1$) and Cole-Davidson [16] indicates the asymmetric distribution of relaxation time curve ($\alpha = 0$ & $0 \leq \beta \leq 1$) models.

The complex plane plots for DE-NMF and DE-DMF system are given in Figs. 4 and 5, by taking the real term along the x axis and imaginary term along the y axis. These planes are in semi-circular form; therefore the dielectric model for the fitting dielectric parameters suitable for these systems is the Debye model. Therefore the complex permittivity spectra have been fitted in the Debye model along

with ϵ_0 , ϵ_∞ , and τ by using least square fit method.

$$\epsilon^*(\omega) = \epsilon_\infty + \frac{\epsilon_0 - \epsilon_\infty}{1 + j\omega\tau} \quad (4)$$

where ϵ_0 , ϵ_∞ and τ are the adjustable parameters. These dielectric parameters were obtained from a 'nonlinear Least-Square fit method' [17].

IV. RESULTS AND DISCUSSION

A. Static Dielectric Properties

Table I represents the values of dielectric parameters such as static dielectric constant (ϵ_0), and relaxation time (τ). It is clear from the table that as the concentration of amides increases in DE system, the static dielectric constant value increases gradually; it means that the molecular size of the DE-NMF and DE-DMF systems increases with increasing the mole fraction of amides in the system.

The static dielectric constant values of amide rich region are high as compared to the values of DE rich region in the system. Similarly, the values of relaxation time also increase with the concentration of amides till 0.7 volume percent in the DE system and then decrease for all temperatures. It is due to the formation a large chain like structure of amides in the mixture.

B. Excess Properties

The information related to the structural changes of liquid 1 (DE) and 2 (Amides) may be obtained by excess properties of dielectric constant and relaxation time [18]

The excess permittivity (ϵ^E) is defined as

$$\epsilon^E = (\epsilon_0 - \epsilon_\infty)_m - [(\epsilon_0 - \epsilon_\infty)_1 x_1 + (\epsilon_0 - \epsilon_\infty)_2 x_2] \quad (5)$$

where x - mole fraction and suffices m , 1, 2 represent mixture, liquid 1 and liquid 2 respectively.

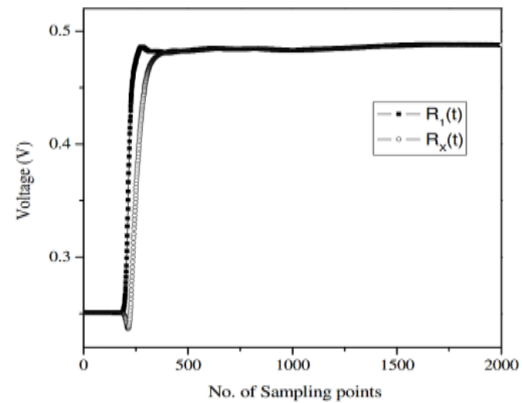

Fig. 3 Reflected pulse with sample $R_x(t)$ and without sample $R_1(t)$

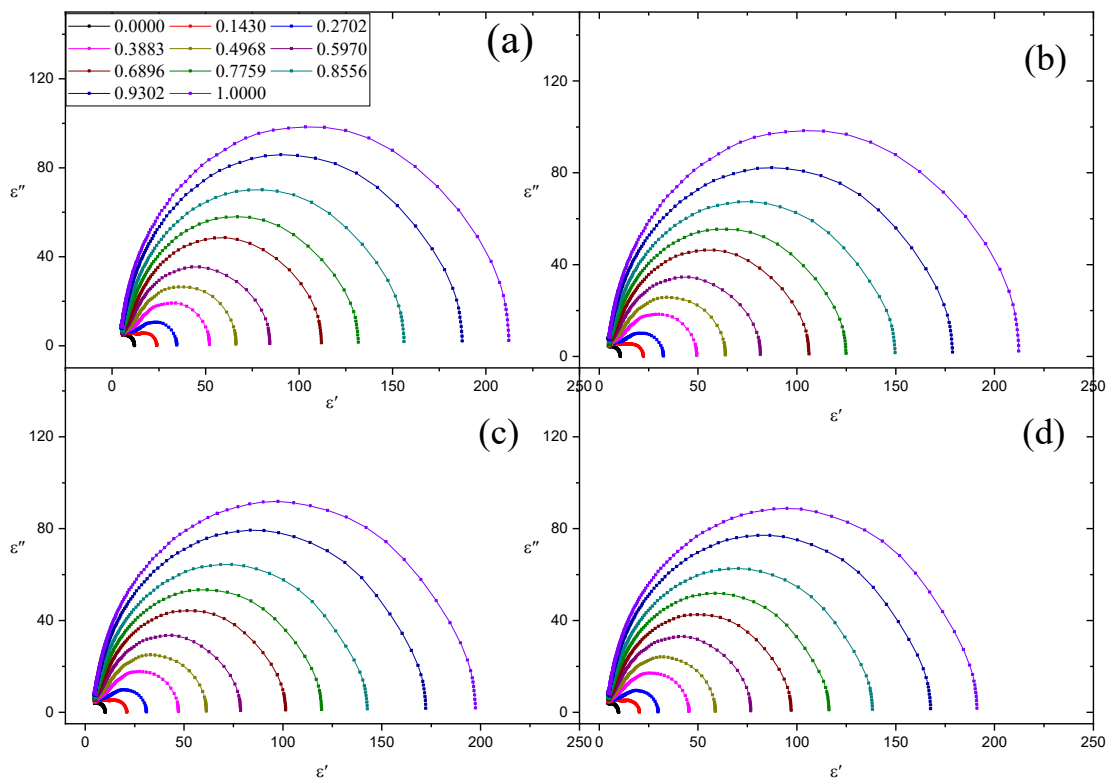

Fig. 4 Complex plane plot of dielectric constant (ϵ') vs. dielectric loss (ϵ'') for various concentrations of NMF in DE at (a) $T = 10$ °C, (b) $T = 15$ °C, (c) $T = 20$ °C, and (d) $T = 25$ °C

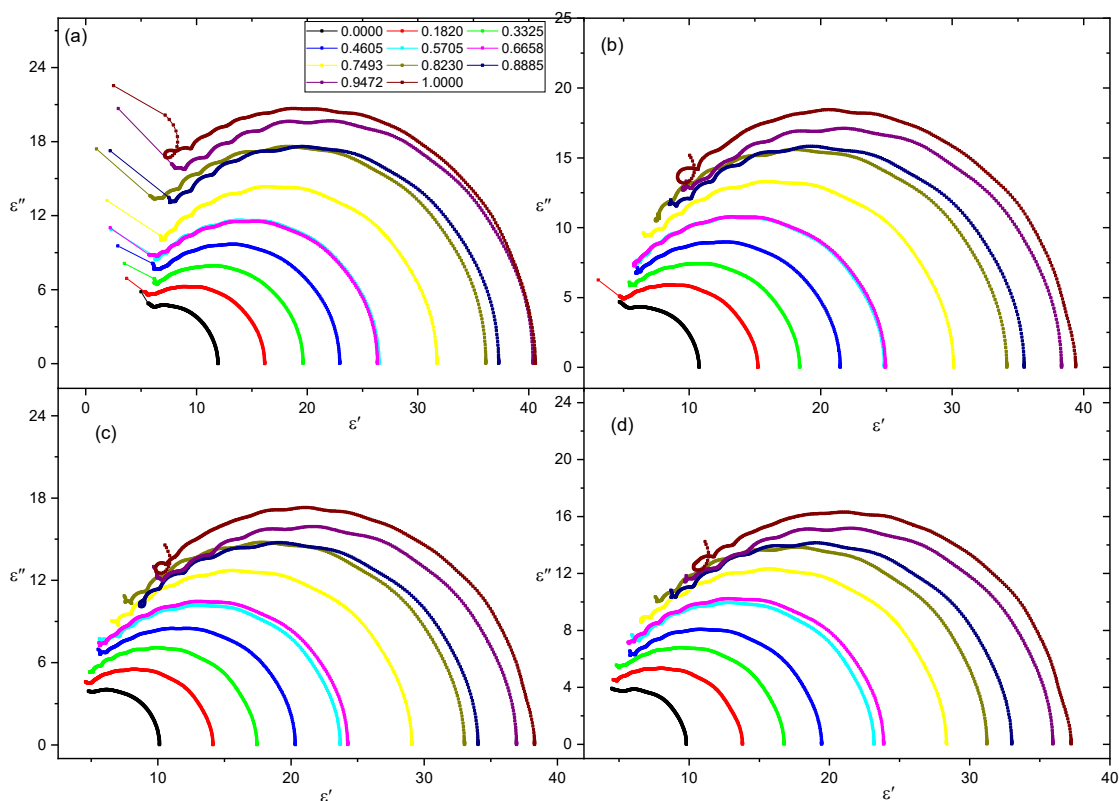

Fig. 5 Complex plane plot of dielectric loss (ϵ'') vs. dielectric constant (ϵ') for various concentrations of DMF in DE at (a) $T = 10$ °C, (b) $T = 15$ °C, (c) $T = 20$ °C, and (d) $T = 25$ °C

- $\epsilon^E = 0$ indicates that liquid mixture constituents do not interact.
- $\epsilon^E < 0$ indicates that mixture constituents interact such that the complete number of effective dipoles presented in the mixture gets reduced.
- $\epsilon^E > 0$ indicates that mixture constituents interact such that there is increase in the number of effective dipoles contributed in the mixture values.

In the DE-Amide system the excess properties change with the concentration of the amide. These values are negative as the concentration of amides increases in the DE-Amide system, which indicates that the system's effective dipoles get reduced. These values are positive as the concentration of DE increases in the system, which represents that the system's effective dipoles get increased. Similarly, the excess inverse relaxation time is defined as

$$(1/\tau)^E = (1/\tau)_m - [(1/\tau)_1 x_1 + (1/\tau)_2 x_2] \quad (6)$$

where x - mole fraction and suffices m , 1 , 2 represent mixture, liquid 1 and liquid 2 respectively.

The inverse relaxation time analogy is taken from spectral line broadening in the resonant spectroscopy [19].

- $(1/\tau)^E = 0$ indicates there is no change in the dynamic of liquid 1 and 2 interaction.
- $(1/\tau)^E < 0$ indicates liquid 1 and 2 interaction produces a field such that total effective dipoles rotate slowly.

- $(1/\tau)^E > 0$ indicates liquid 1 and 2 interaction produces a field such that total effective dipoles rotate faster i.e., the field cooperates in the rotation of dipoles.

In DE-NMF system, the excess inverse relaxation time values are positive in DE rich region and negative in NMF rich region for all temperatures. It means that the liquid 1 (DE) and 2 (NMF) interaction produces a field such that the effective dipoles of the mixture rotate quickly i.e., the existing field cooperates in the rotation of dipoles. The negative value of excess inverse relaxation time indicates the slower rotation of the dipoles of the system. Fig. 6 shows the excess properties of the DE-NMF system.

In DE-DMF system, the excess inverse relaxation time values are negative for various concentrations at all temperatures. The negative value of excess inverse relaxation time indicates slower rotation of the dipole of the system. The excess properties of the DE-DMF system are shown in Fig. 7.

The Redlich-Kister equation [20], [21] represents the excess properties as discussed above, of binary liquids DE and amides prepared at fixed temperatures and are given as

$$A^E = (x_1 x_2) \sum_n B_N (x_1, x_2)^n \quad (7)$$

where A is either ϵ^E or $(1/\tau)^E$, x_1 and x_2 are molar fraction of two liquids, the coefficient B_N is a fitting coefficient to be

defined by the least square fit method and the values of N varies from 0 to 3 are listed in Table II.

TABLE I
STATIC DIELECTRIC PARAMETERS AT DIFFERENT TEMPERATURES FOR DE-AMIDES SYSTEMS

Volume fraction of amides	ϵ_0			
	T = 10 °C	T = 15 °C	T = 20 °C	T = 25 °C
	DE+NMF			
0.0	11.98(0)	10.88(0)	10.24(0)	25.95(0)
0.1	29(1)	21.56(1)	20.43(1)	45.6(0)
0.2	33.84 (4)	31.21(1)	30(6)	86.58(5)
0.3	51.34(1)	47.74(2)	38(5)	44.2(3)
0.4	65.38(2)	62.41(7)	59.89(3)	57.58(6)
0.5	83.04(7)	79.7(2)	77.23(2)	75.68(1)
0.6	110.82(5)	104.33(1)	99.8(1)	95.83(0)
0.7	130.74(2)	123.35(7)	118.06(2)	114.07(3)
0.8	156.69(1)	147.67(2)	140.25(1)	135.74(6)
0.9	186.07(2)	177.19(8)	169.69(1)	164.39(2)
1.0	212.26(0)	204.7(0)	197.39(0)	191.12(0)
	DE+DMF			
0.0	12.57(1)	10.94(1)	10.33(0)	9.98(1)
0.1	15.96(2)	14.89(1)	13.96(0)	13.59(0)
0.2	14.74(1)	17.97(1)	17.14(1)	16.53(0)
0.3	22.47(2)	21.17(1)	20.11(1)	19.15(1)
0.4	26.22(1)	24.52(1)	23.39(1)	22.9(1)
0.5	26.06(1)	24.62(1)	23.91(1)	23.48(1)
0.6	31.42(1)	29.73(1)	28.6(2)	27.82(2)
0.7	36.5(3)	33.81(1)	32.63(1)	30.75(2)
0.8	37.22(1)	34.86(3)	33.38(3)	32.16(3)
0.9	40.61(2)	37.66(3)	36.05(4)	34.87(3)
1.0	41.2(4)	39.08(0)	37.69(2)	36.41(2)
	τ (ps)			
	DE+NMF			
0.0	54.62(0)	44.25(0)	32.22(0)	25.95(0)
0.1	73.72(0)	60.06(1)	53.79(0)	45.60(1)
0.2	150.38(9)	100.33(3)	92.91(9)	86.58(2)
0.3	188.58(4)	141.96(6)	127.37(1)	110.75(5)
0.4	198.50(3)	165.24(3)	140.79(4)	125.39(7)
0.5	203.65(4)	168.06(4)	153.71(8)	141.21(9)
0.6	206.23(2)	173.79(5)	159.13(3)	148.08(0)
0.7	206.02(6)	173.04(6)	158.19(6)	143.41(1)
0.8	205.54(8)	172.67(8)	152.73(3)	139.93(1)
0.9	189.73(2)	166.46(9)	148.68(8)	133.37(2)
1.0	172.78(0)	149.21(0)	142.89(0)	130.85(0)
	DE+DMF			
0.0	9.75(3)	9.61(3)	9.42(3)	9.35(3)
0.1	113.26(3)	13.17(2)	12.81(2)	12.25(2)
0.2	13.63(4)	13.54(2)	13.29(2)	12.93(1)
0.3	14.61(3)	14.17(2)	13.57(1)	12.86(1)
0.4	15.07(3)	14.51(2)	13.81(1)	13.56(1)
0.5	14.99(2)	14.59(2)	14.17(2)	14(2)
0.6	14.47(1)	13.8(2)	13.2(2)	12.69(2)
0.7	14.43(2)	13.59(1)	13.12(1)	12.09(2)
0.8	13.51(0)	12.71(2)	12.1(3)	11.48(3)
0.9	12.47(1)	11.58(2)	11.01(3)	10.55(3)
1.0	12.18(4)	11.34(0)	10.64(1)	10.18(2)

Number in the bracket represents error in the corresponding value, e.g., 29 (1) means 29 ± 0.01 .

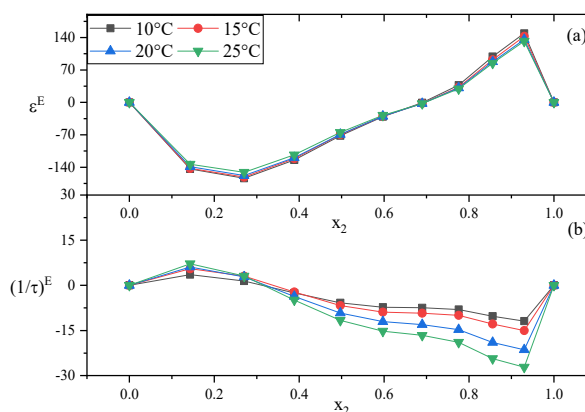

Fig. 6 (a) ϵ^E versus mole fraction (x_2) of NMF in DE; (b) $(1/\tau)^E$ versus mole fraction (x_2) of NMF in DE

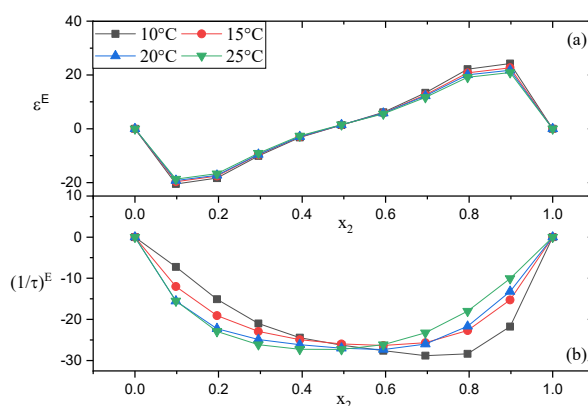

Fig. 7 (a) ϵ^E versus mole fraction (x_2) of DMF in DE; (b) $(1/\tau)^E$ versus mole fraction (x_2) of DMF in DE

TABLE II
 B_N COEFFICIENT OF THE REDLICH-KISTER EQUATION FOR DE-AMIDE SYSTEMS

Temperature in °C	Excess permittivity			
	B_0	B_1	B_2	B_3
10	-34.81	565.99	-76.66	2409.4
15	-37.32	513.55	-108.53	2413.27
20	-38.42	510.08	-133.14	2300.84
25	-36.56	468	-109.08	2266.11
	Excess inverse relaxation time			
10	-29.87	-0.35	-21.08	-156.28
15	-36.96	-2.4	-18.26	-207.29
20	-51.36	-14.85	-42.45	-255.82
25	-65.16	-22.12	-58.86	-312.92

V. CONCLUSION

The DE-amide systems obey the Debye model. Static dielectric property values for DE-amide systems increase with the increase in the concentration of amides. In the end the excess properties of these systems are determined.

ACKNOWLEDGMENT

The department of Science and Technology, New Delhi is

grateful acknowledged (Project no. SR/S2/LOP-25/2007) for laboratory facility. We are thankful to A. C. Kumbharkhane for providing TDR facility and Dr. S. C. Mehrotra, Ramanujan Chair Professor, Department of Computer Science and IT, Dr. B.A.M. University, Aurangabad for their valuable discussion and suggestions.

REFERENCES

- [1] A.V. Patil, G.N. Shinde, V.P. Pawar, "Dielectric relaxation study of hydrogen bonded structures in ethanolamine with diethanolamine using TDR technique," *J. Mol. Liq.*, 168, April. 2012, pp- 42-46.
- [2] A.V. Patil and V.P. Pawar, "Microwave dielectric spectra and molecular interaction in a binary mixture of ethanolamine with diethanolamine," *J. Mol. Liq.*, 188, Dec. 2013, pp-1-4.
- [3] A.V. Patil, B.D. Achole, G.N. Shinde and V.P. Pawar, "Study of molecular interaction in binary mixture of dimethylene chloride with dimethylformamide using Bruggeman model," *Scholars Research Library, Archives of Applied Science Research*, 4(4), 2.12, pp-1665-1669.
- [4] V.P. Pawar and A.V. Patil, "Dielectric relaxation studies on molecular interaction in binary mixture of dimethylene chloride with methylformamide," *Fluid Phase Equilib.*, 376, 2014, pp-111-115.
- [5] V.P. Pawar, S.C. Mehrotra, "Dielectric relaxation study of liquids having chloro group with liquids: I Chlorobenzene with methanol, ethanol and propan-1-ol," *J. Sol. Chem.*, 31(7), 2002, pp-559-576.
- [6] V.P. Pawar, S.C. Mehrotra, "Dielectric relaxation study of chloro group with associative liquids. II. 1,2-dichloroethane with methanol, ethanol, and 1-propanol," *J. Sol. Chem.*, 31(7), 2002, pp-577-588.
- [7] A.V. Patil and V.P. Pawar, Dielectric relaxation study of dieethanolamine with triethanolamine at melting points using TDR," *Bio-nano Frontier*, 8(3), 2015, pp-308-311.
- [8] V.P. Pawar and A.V. Patil, "Dielectric and thermodynamic properties in a binary mixture of dimethylene with formamide," *J. Mol. Liq.*, 206, 2015, pp-239-243.
- [9] C. M. Roland, R. B. Bogoslovo and R. Casalini et al, "Thermodynamic scaling and the characteristic relaxation time at the phase transition of liquid crystal," *J. Chem. Phys.*, 128, 2008, pp-224506.
- [10] G. H. William, G. G. Steven and K. W. Johnson, "Thermodynamic Properties of the Fluid and solid phases for inverse power potentials," *J. Chem. Phys.*, 55(3), 1971, pp-1128.
- [11] C. E. Shannon, "Communication in the presences of noise," *Proc. IRE.*, 37, 1949, pp-10.
- [12] H. A. Samulon, Spectrum analysis of transient response curves, *Proc. IRE.*, 39, 1951, pp-175.
- [13] R. H. Cole, J. G. Berberian, S. Mashimo, G. Chryssikos, A. Burns and E. Tombari, Time domain reflection method for dielectric measurements to 10 GHz, *J. Appl. Phys.* 66, 1989, pp-793.
- [14] P. Debye, "Polar Molecules; The chemical catalogue company," Dover, New York, 1929.
- [15] K. S. Cole and R. H. Cole, Dielectric relaxation in glycerine, *J. Chem. Phys.*, 18, 1950, pp-1417.
- [16] D. W. Davidson and R. H. Cole, Dielectric relaxation in glycerine, *J. Chem. Phys.*, 18, 1950, pp-1417.
- [17] P.R. Bevington, "Data reduction and error analysis for the physical sciences," McGraw Hill: New York, 1969.
- [18] M. Tabellout, P. Lancelleur, J.R. Emery, D. Hayward and R.A. Pethrick, "Dielectric, ultrasonic and carbon-13 nuclear magnetic resonance relaxation measurements of t-butyl alcohol-water mixtures," *J. Chem. Soc. Faraday Trans.*, 86, 1990, pp-1453-1501.
- [19] S.C. Mehrotra and J.E. Boggs, "Effect of collision-induced phase shifts on the line widths and line shifts of rotational spectral lines," *J. Chem. Phys.*, 66, 1977, pp-5306-5312.
- [20] M. I. Aralaguppi, T. M. Aminabhavi, R. H. Balundgi and S. S. Joshi, *J. Phy. Chem.*, 95, 1991, pp-5299.
- [21] S. F. Al-Azzawl, A. M. Awwad, A. M. Al-Dujaili and M. K. Al-Noori, *J. Chem. Engg. Data*, 35, 1990 pp-463.