

Characterization and Behavior of Level and Flow Transmitters Available on the Market

V. A. C. Vale, E. T. L. Cöuras Ford

Abstract—In view of the requirements of the current industrial processes, the instrumentation plays a critical role. In this context, this work aims to raise some of the operating characteristics of the level and flow transmitters, in addition to observing their similarities and possible limitations configurations.

Keywords—Flow, level, instrumentation, configurations of meters, method of choice of the meters, instrumentation in the industrial processes.

I. INTRODUCTION

IN many industrial and commercial processes to know the level of a tank and the mass flow in a pipe is of great importance, affecting the efficiency, durability of equipment (mixers, tanks), the final product reliability, productivity, safety, practicality of maintenance and ease correcting errors [1].

A typical example is a pump gas station or logistics of a petrochemical refinery, where their clients should pay exactly the volume consumed. Other numerous examples may be mentioned, as the petrochemical industry to the conception of their derivatives, as well as the pharmaceutical and chemical industry, in which the accuracy of the measurements of the components is essential.

In the beginning of the industrial age, the worker reached the goals mentioned by manual control of these variables (level and flow), using only simple tools: manometer, thermometer and manual valves, this was sufficient because the processes were simple.

With the passage of time the processes had become more complex require increased automation in industrial processes, through the instruments of measurement and control, among which are the level and flow transmitters [2]. Added to this, there was also an increase in the exigencies of the sectors of inspections and the end customer, both global and national, in addition to the competition between the industries.

II. DEFINITIONS

To facilitate understanding usually define level as the height of the content (liquid or solid) in a reservoir [3]. The level

Valentina Alessandra Carvalho do Vale, is Ph.D. Student in Electrical Engineering; M.Sc. in Mechanical Engineering; Engineer of Safety; Electrical Engineer. Universidade Federal do Pernambuco – UFPE / PPGEE, Recife – PE, Brazil (e-mail ale.vale.ssandra@gmail.com).

Elmo Thiago Lins Cöuras Ford, is Ph.D. in Mechanical Engineering; M.Sc. in Administration; M.Sc. in Mechanical Engineering; Engineer of Safety; Mechanical Engineer; Automotive Engineer. Universidade Federal do Rio Grande do Norte – UFRN / PPGCEM, Av. Senador Salgado Filho, S/N, 59072-970, Natal - RN, Brazil (e-mail: elmocouras@hotmail.com).

measurement, although it has simple concept, sometimes requires accurate techniques and artifices, and can fall within in the direct or indirect methods.

The direct measurement method has reference to the position of the upper level of the substance, his method, although simpler, cannot always be used. The indirect measurement method uses a second variable to measure. Examples are presented in Table I. Another classification is possible for level meters, as continuity. In the discontinuous measurement, there is only an indication only when the level reaches specific points, such as, for example, maximum and minimum alarm conditions. In continuous measurement, it is possible to know the level at any point.

TABLE I
METHODS OF LEVEL MEASUREMENTS FOR LIQUIDS AND SOLIDS

	Method	Liquids	Solids
Direct	Rules or overall dimensions	×	×
Indirect	Thrust (Strain Gauge)	×	-
Indirect	Differential pressure	×	-
Indirect	Electrostatic capacitance	×	×
Indirect	Radiation	×	×
Indirect	Weighing	×	×

Mass flow is the ratio of the measure of the amount of mass that passes through some means or path by a time interval [4]. These sensors can also be used for gas flow measurement. Today there are many commercially available mass flow meters, each one with various unique characteristics of measuring methods.

The method of choice influences on characteristics such as accuracy, size of equipment, useful life, load loss, measuring state (liquid, gas or a mixture of the above, only fluids). The most common meters calculate the mass flow from the measurement of fluid velocity or a change in power, however there are other methods.

It is important to mention that some of the methods measure the volumetric flow rate ($F_{\text{volumetric}}$), but it can be easily converted to mass flow (F_{mass}), since they know the product being measured, consequently the specific mass (ρ_{product}), according to (1) [5]:

$$F_{\text{mass}} = \rho_{\text{product}} \cdot F_{\text{volumetric}} \quad (1)$$

Transmitters are instruments that measure a process variable and transmit this variable for an instrument that can be receptor, indicator, recorder, controller or a combination of these. There are several types of signals that can be transmitted whereby pneumatic, electric, hydraulic and

electronic [6], that vary with the purpose and/or application.

The level and flow transmitters are devices consisting of sensors and an "interpreter circuit", thus the sensors receive and respond to a stimulus, resulting in an electronic variable. The answers interpreted in an electronic circuit, which show a value with the unit corresponding to the transmitter and/or as desired.

III. DISPLACER TYPE LEVEL TRANSMITTER

This level transmitter provided with a detector that uses Archimedes' principle, in which a body immersed in a fluid subjected to action of a vertical force directed of down to upwards and equal modulo to the weight of the displaced liquid. This force exerted by fluid in the body is called thrust, which will be greater the higher the density of the liquid.

The sensor commonly used in this type of transmitter known as Shifter (displacer). It has the shape of a hollow cylinder, made of material and length, which vary according to the application, may have anticorrosive power or support high temperatures. Inside the cylinder, if necessary, granulated counterweights deposited, in order to adjust the weight of the displacer. A typical shifter is shown with its parts (hoist, stem and displacer) in Fig. 1.

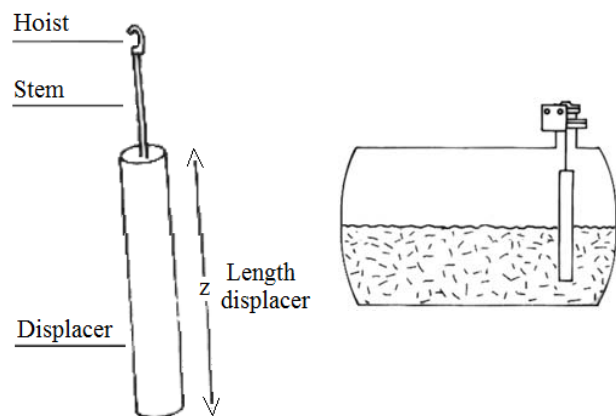

Fig. 1 Displacer typical

The displacer can work directly inside the machine or within a compartment that called chamber, depending on the dynamic characteristics of the process, the physical properties of the fluid and facility of maintenance that is desired.

The chamber consists of two parts, as shown in Fig. 2. The lower chamber keeps the displacer and two flanged connections (or threaded connections) to yours fixation in the equipment. The upper chamber encloses the torque arm and, when the two connections are located in the lower chamber, allows the displacer removal without to be necessary to disassemble the equipment.

A common application is found in separator of oil and salt water on a marine platform of oil extraction. In this application, the level transmitter of the buoyancy type must ensure a level of safe between the fluids to make their separation by an interface through density difference, as

shown in Fig. 3.

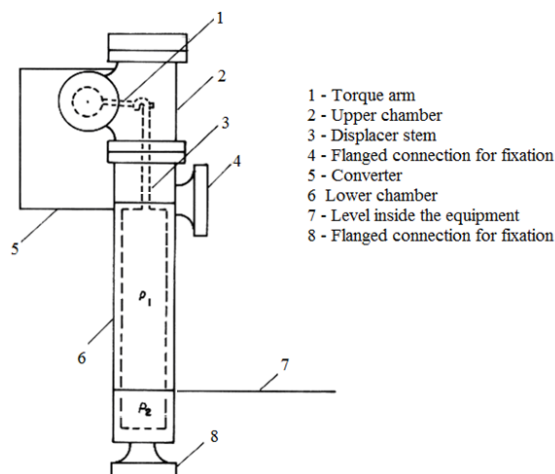

Fig. 2 Chamber for Displacer

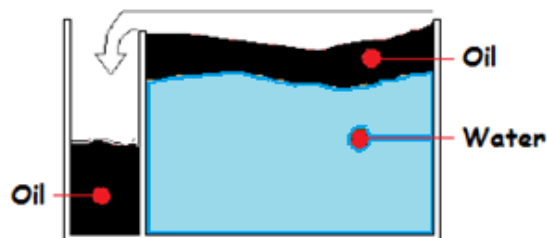

Fig. 3 Separator of oil and salt water

IV. LEVEL TRANSMITTER OF THE TYPE DIFFERENTIAL PRESSURE

These instruments, when used for level measurement, measure pressure differences that caused by the liquid column of this equipment whose level desired to measure.

The most common operating principle of differential pressure transmitters of the diaphragm type is the balance of forces. The pressures that define a differential data applied through the input connections of the instrument to two chambers situated at opposite sides and separated by a sensitive element (diaphragm). These pressures, acting on the element with a particular surface, produce forces with same action line and opposite directions, generating a resultant force. This resultant force, in the case of transmitter of the capacitive cell type, causes a variation in the capacitances C1 and C2, as schematized in Fig. 4. This variation proportional to the differential pressure converted, amplified, providing an output signal current at the output of the transmitter.

For an open tank, the high-pressure side of the differential pressure transmitter is connected via the lower part socket of the tank, and the low-pressure side is opened to the atmosphere. Since the static pressure of the fluid is directly proportional to the weight of the liquid, this can be obtained by measuring of the first. In this case, the pressure gauge may be used instead of the differential pressure transmitter, as shown in Fig. 5.

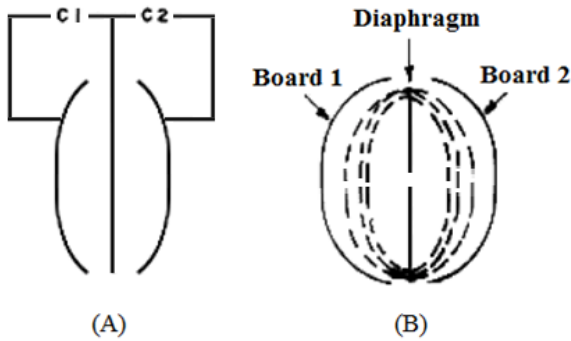

Fig. 4 Model of Capacitors in Cell Capacitive

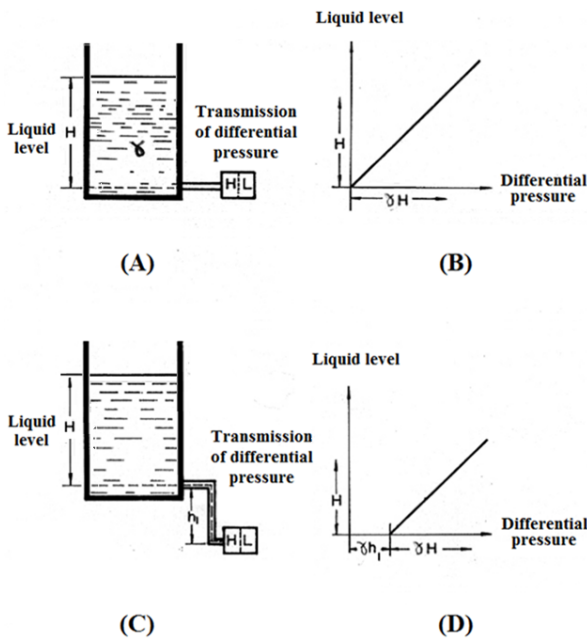

Fig. 5 Level measuring of the differential pressure type (open tank)

On a closed tank, if the pressure inside the tank is different from the atmospheric pressure, the sides of high and low pressure are individually connected by tubes in the lower and upper tank, respectively, to obtain the differential pressure that is proportional to the level of the liquid, as shown in Fig. 6.

V.MASS FLOW TRANSMITTER

To speak of mass flow transmitter, it is necessary to start to talk about the Coriolis measure. The Coriolis measuring comprises a tube that has an important feature not be influenced by the density, pressure and viscosity of the fluid. Usually, it has a shape of "U", is able to vibrate at its natural frequency due to magnetic device located on the folds of the tube. The vibration is of small amplitude and frequency of about 80 Hz. Then the fluid passes through the tube, it is forced to follow its vertical movement. When the tube is moving upward, during a half period, the stream of fluid in the measure resist to the movement with a force downward on the tube. As the fluid was forced a little upward, when it leave of

the measure it is again forced to return to previous position, causing a torsion in the tube. When the tube moves downwards in the second half of the period, it suffers the torsion, but in the opposite direction. Quantifying this torsion can reach the mass flow, since they are proportional. In Fig. 7 is schematized operation.

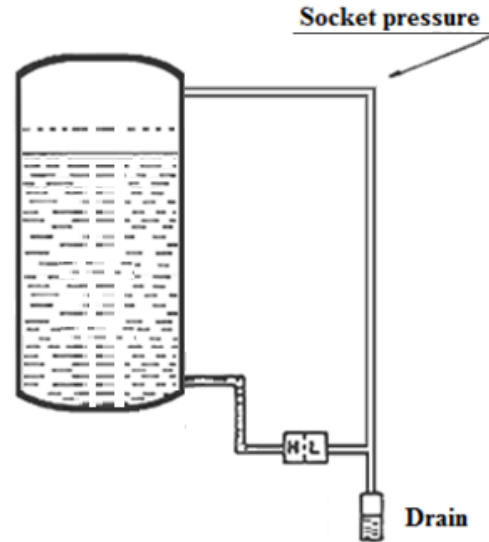

Fig. 6 Level measuring of the differential pressure type (closed tank)

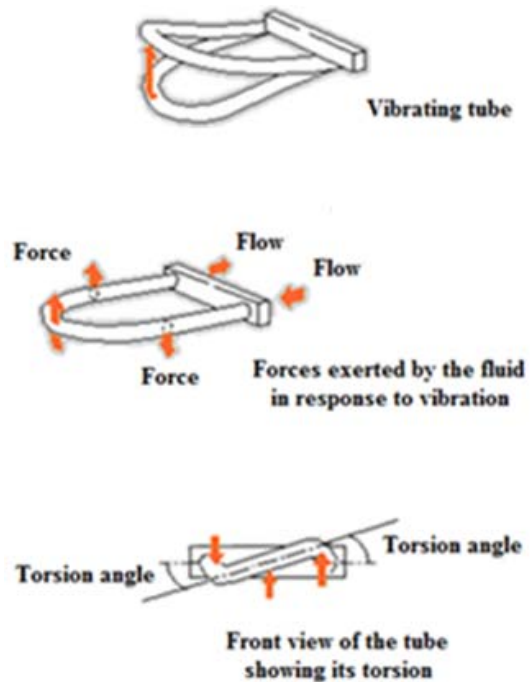

Fig. 7 Coriolis Measure

One can measure mass flow by measuring the temperature of the fluid. As for the Coriolis measuring, the measured value is independent of the density, pressure and viscosity of the fluid. These meters use a heated element isolated from the

path of the fluid. The flow causes heat removal from the sensor. The rate of heat exchanged is directly proportional to mass flow. Other types of mass flow meters use a rotations meter associated with a turbine being known as mechanical liquids flow sensors.

An application of this type of transmitter with gas is found in combustion engines in that a mass air flow (MAF) sensor is an electrical component for determining the mass of air that enters. This can allow the engine control module (ECM) provides the correct amount of fuel for the fuel-air mixture. By strictly controlling the ratio of the mixture, the combustion can become more efficient, while emissions are reduced.

VI. CONCLUSION

The instrumentation brought a major advance in industrial processes, particularly with meters of essential variables such as level and flow. These are very useful when you need to measure levels and flows in scenarios with turbulence in addition to the presence of gases and foams. However, the choice of type of meter is not as simple a task as it might seem at first. Excluding applications for liquids like water that does not require great care in choosing the specification of the sensor, should take into consideration the physical and chemical characteristics, the state of matter, the interference of the variables temperature and pressure, beyond of the installation location.

ACKNOWLEDGMENT

Thanks go to CAPES, UFPE and UFRN for providing the means to carry out this work.

REFERENCES

- [1] Yokogawa – “Manual dos Transdutores e Conversores”, série 2280 A. 1997.
- [2] Poletto, Eduardo Leseire – “Aprimoramento de uma bancada de ensaios de desempenho de compressores herméticos visando reduzir incertezas de medição”, Florianópolis, Fevereiro de 2006.
- [3] Coelho, Marcelo S. – “Instrumentação de Sistemas”, Cubatão, São Paulo, Brasil, Janeiro de 2011.
- [4] Kilian, Christopher – “Modern Control Technology: Components & Systems”, 2ed, 2004.
- [5] Schneider, Paulo Smith – “Medição de Velocidade e Vazão de Fluidos”, 2000.
- [6] Santana, Rodolfo Siqueira – “Implementação de uma malha de controle para um sistema de bombeamento – Um estudo de caso para a modulação de vazão em uma planta piloto”, Belo Horizonte, Brasil, Junho de 1998