

Case on Manufacturing Cell Formation Using Production Flow Analysis

Vladimír Modrák

Abstract—This paper offers a case study, in which methodological aspects of cell design for transformation the production process are applied. The cell redesign in this work is tightly focused to reach optimization of material flows under real manufacturing conditions. Accordingly, more individual techniques were aggregated into compact methodical procedure with aim to built one-piece flow production. Case study was concentrated on relatively typical situation of transformation from batch production to cellular manufacturing.

Keywords—Product/Quantity analysis, layout, design, manufacturing process.

I. INTRODUCTION

THE following research deals with theoretical background for application of one-piece concept by applying the principles of Product/Quantity (P-Q) analysis and Production flow analysis (PFA). Research methodology is applied under real conditions in company, which is manufacturing bicycle components. In generally, companies' reason for radical changes of manufacturing process structures are mainly motivated by recognition that so called process type layout do not suit just-in-time philosophy. That kind of planning-oriented production system ends up being a system that requires pushing for sales. The factory push their outputs to retailers, retailers are returning what they cannot sell and returned products ends up as a dead inventory.

The concept of so-called one-piece production differs radically from mentioned systems. By contrast this system outputs products based on the needs of the assembly processes, which are the closest processes to the market and therefore customer. Only when products have been shipped out more products are ordered from manufacturing department.

II. RESEARCH BACKGROUND

The sense of material flow optimisation is to help planners to satisfy customer's needs in shortened manufacturing time cycles. The subject of material flow optimisation falls into production flow management or logistic management, which

includes all aspects of all movements of raw materials, work in process, or finished goods within a plant or warehouse' [1].

Material flows can be implemented as:

1. Discrete flows, which are typical mainly for a batch production. This category involves the manufacture of medium-sized lots of the same item or product. The lots may be produced only once, or they may be produced at regular intervals [2].
2. Continuous material flows are ordinarily applied in chemical and food industry. While these are examples of flow production, the term also applies to the manufacture of either complex single parts or assembled products.

The role of the cell formation is transformation of discrete material flows to almost continuous material flows with the aim to change planning-centered production on one-piece production. According to more authors (see for instance: [3], [4], [5]) by implementing one-piece flow, organizations can obtain dramatic reductions in work-in-process inventory. This reduction in inventory is realized due to:

- 1) Parts are not being stored in containers (unit loads) at operations while they are being processed. Instead one piece at a time is processed in cells and ideally only one piece is in transit between operations.
- 2) Parts are made as they are ordered. Batches or lots of parts are not staged between operations waiting to be scheduled and then to be processed.

Another vantage of this concept is the effect called Zero defect production [6]. It is realized by building mistake-proofing devices into production line, in which work pieces are inspected one at the time. The concept one-piece flow production has been introduced relatively lately, but it seems to be very significant in today's competitive and dynamic manufacturing environment.

The closest theory to one-piece production was brought by Burbidge [7] that is known as Production Flow Analysis (PFA) for planning Group Technology (GT). Sekine [8] purposefully analyzed the basic principles of process flow building and offered detailed case studies of how various industries designed unique one-piece flow systems (parallel,

V. Modrák is with the Manufacturing Management department, Technical University of Košice, Faculty of Manufacturing Technologies, Slovakia, phone: 00421-51-7722828; fax: 00421-51-7733453; e-mail: vladimir.modrak@tuke.sk

L-shaped, and U-shaped floor plans) to meet their particular needs. The basic conditions for establishing one-piece flow systems are:

1. Make the factory layout conducive to the overall production flow.
2. The factory must include clear pathways.
3. The production line should clearly distinguish between material input and product output
4. The production line should consist mainly of single-operator U-shaped cells.
5. Include thorough inspection in the layout.
6. Minimize in-process inventory.

In generally, very small work pieces are not suitable to one-piece production due to the waste involved in the setup, positioning, and removal of such small items. This concept is also inappropriate if changeover times are long.

III. PROBLEM AND METHOD DESCRIPTION BY A CASE STUDY

The company, where case study was conducted, produces bicycle components, which differ in shapes and sizes. From production type point of view the company belongs under category of batch production. This category involves manufacturing of medium-sized lots of the same item or product. Generally speaking, lots can be produced only once, or they can be produced at regular intervals. In the given case lots are produced more or less at regular intervals. Consequently, the manufacturing equipment was conventionally designed for higher rates of production. The machine tools are combined with specially designed jigs and fixtures, which increase the output rate. Flexibility of production is ensured by semi-automatic machines. Company aims its activity towards to increase volume of production by innovation of production facilities and development of management methods. Current production equipment layout and material flow during processing in a mentioned factory are depicted in Fig. 1.

A. Theoretical Background for Conducting a P-Q Analysis

After determining current situation in production process next key for building successful operations is an effective system design. An effective design should take into account an organization's products, facilities, and procedures for planning and controlling operations, minimum ergonomic requirements for equipment, and short and long-term goals. A system design helps to define a products costs structure, determines an organizations competitive position for several years. It is essential to find a design that meets present and future needs. It should not tie operations to outdated technology. It produces superior products and enhances organization competitive abilities. First important step for an effective system design is Product—Quantity (P-Q) analysis. Sekine and Arai [9] recommend taking a P-Q Analysis as criterion for suitability of one-piece flow concept by using 3 following ratios (see Fig. 2):

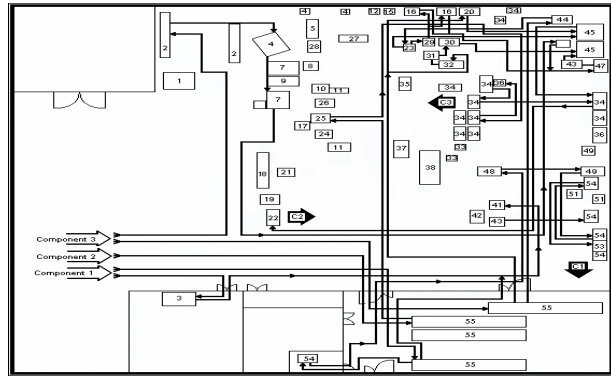

Fig. 1 Production equipment layout and material flow before cell formation

- the 20:80 ratio (line X1)
- the 30:70 ratio (line X2)
- the 40:60 ratio (line X3)

X1- amount of manufactured products related to 20% of produced assortment

X2- amount of manufactured products related to 30% of produced assortment

X3- amount of manufactured products related to 40% of produced assortment

Outlined ratios in P-Q diagram for individual X-es are the source for decision making about production equipment layout in factory. They are as follows:

- a) if X1 approaches 80%, then building a wide-variety small-lot production line is reasonable i.e. apply one-piece flow conception,
- b) if X2 lays around 70% value, decision about production equipment layout depends more or less on intuition and experience of a manager, even though fuzzy criteria for such decision making are mentioned by Sekine [8],
- c) if X3 approaches 60%, it is reasonable to organize production equipment in technological pattern due to relations between assortment and amount of manufactured pieces being not suitable for implementing one-piece flow principles.

An interval of interest is described in Fig. 3, where area of source thesis is marked. When X2 value in P-Q diagram intersects with Lorence curve at about 70% (see Fig. 3 for narrow decision making interval) manager is having hard time deciding about production layout since there are no clear criterions for such decision. It is up to his knowledge to make a right decision. To eliminate uncertainty in decision making a mathematical algorithm (Fig. 4) is offered for clear decision parameters.

ΔX_2 (in Fig. 3) is difference between actual amount of products X2 and 70% margin defined by theory [%].

ΔX_3 (in Fig. 3) is difference between actual amount of products X3 and 60% margin defined by theory [%]

For defining unambiguous criterions in decision making process between process layout and product layout (typical for

one-piece flow production) by using of P-Q analysis are proposed these rules:

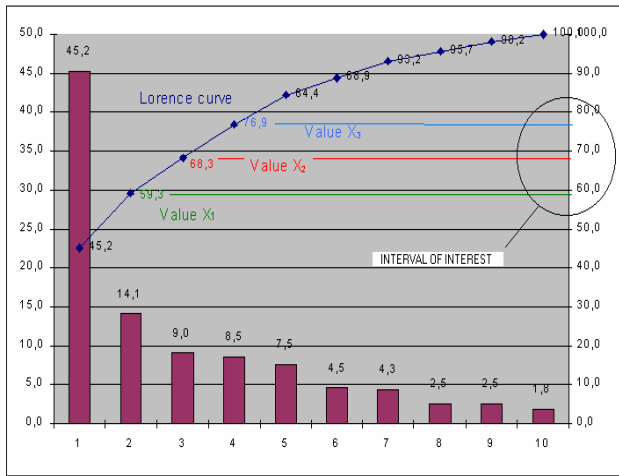

Fig. 2 Theoretical example of P-Q diagram

R1: If value X_2 is greater than or equal 70%, then it is strongly recommended to establish wide-variety small-lot production layout in factory thus implementing one-piece flow conception.

R2: If value X_2 is smaller than 70% and X_2 is greater than 65% or ΔX_3 is greater than ΔX_2 , then it is more or less appropriate to built up wide-variety small-lot production system.

R3: If value X_2 is smaller than 70% but ΔX_2 is greater than ΔX_3 then conditions for implementing one-piece flow are not satisfied so the production equipment layout should be organized in technological pattern.

Open interval $65 < X_2 < 70$ was chosen due to mathematical conditions for application of decision making algorithm.

Presented theoretical hypothesis will be applied and tested on concrete example of real manufacturing company. Further a PFA analysis method will be applied and it will be aimed on optimization of material flows in scope of logistic goals.

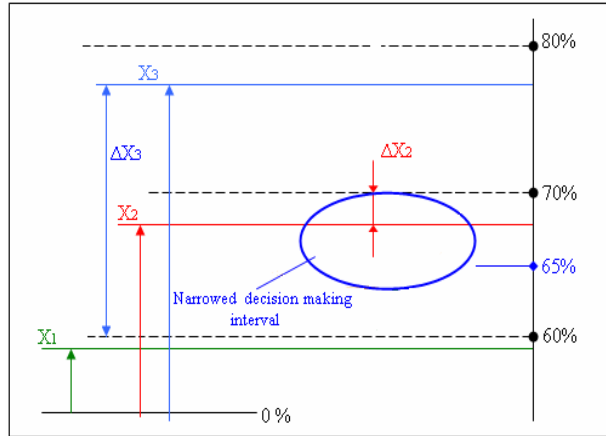

Fig. 3 Interval of the interest

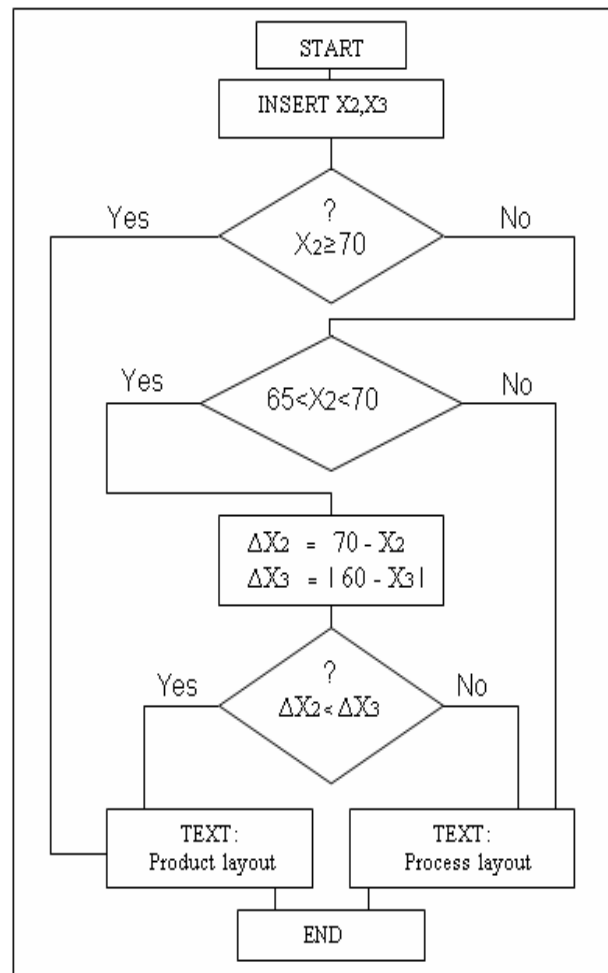

Fig. 4 Decision-making algorithm

B. Initial Data for Conducting P-Q Analysis

Initial production values needed for conducting P-Q analysis are given Table I. They serve for drawing of P-Q diagram and Lorenz Curve showed in Fig. 5.

TABLE I
INITIAL PRODUCTION DATA

Semi-product No.	Quantity (pcs/yr)	Cumul. Quantity (pcs/yr)	Cumul. share (%)
1	405870	405 870	405 870
2	270580	676 450	676 450
3	266966	943 416	943 416
4	256311	1 199 727	1 199 727
5	101700	1 301 427	1 301 427
6	88990	1 390 417	1 390 417
7	76276	1 466 693	1 466 693
8	69404	1 536 097	1 536 097
9	53704	1 589 801	1 589 801
10	39176	1 628 977	1 628 977
11	34702	1 663 679	1 663 679
12	29382	1 693 061	1 693 061

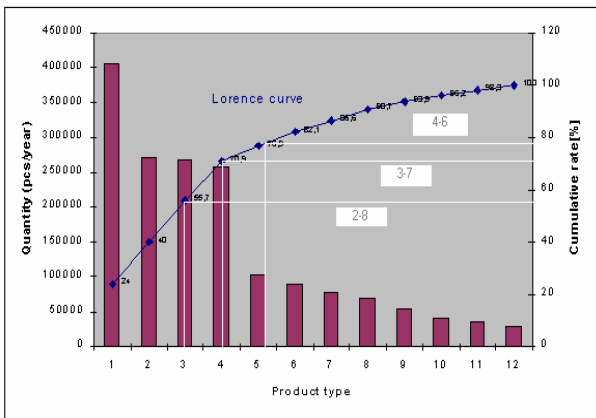

Fig. 5 Actual P-Q diagram (P- product type, Q-quantity)

According to previously determined preconditions, the 30:70 ratio (line X2) is greater than 70% what does it mean that condition R1 of a source thesis was completed for implementing of one-piece conception.

In the table are presented only decisive parts of company production program that have a relevance to the manufacturing process design. The semi-products are divided into three assembled groups. First group of components is represented by frames of bikes. Second group consist from different types of back forks and in third group are clustered different types of front forks.

C. Decomposition of Technological Operations and Layout Redesign

Broad set of working activities done in a manufacturing department for a given assortment of parts to be processed can

be disintegrated into groups according to the group technology concepts. Multi-product process chart based on original process layout is showed in figure 6.

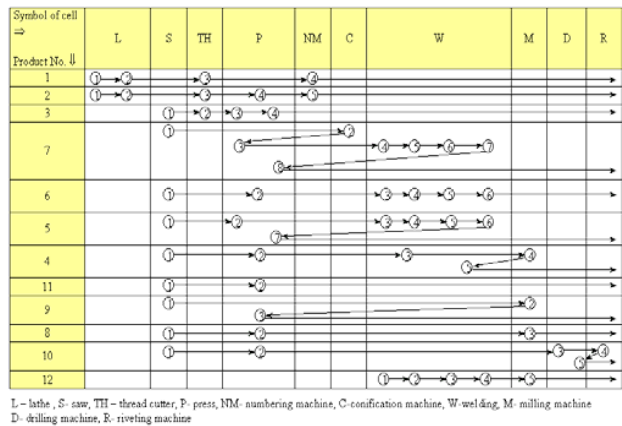

Fig. 6 Multi-product process chart

Based on multi-product process chart further steps of Production flow analysis can be applied. Each stage in PFA seeks to eliminate delays in production flows and operational wastes in a progressively smaller area of the factory. PFA can be defined as comprehensive method for material flow analysis, part family formation, design of manufacturing cells, and facility layout design that was developed in the early 70.s [10]. By PFA related groups of parts are identified and rearranged into a new pattern that brings together packs with similar machine sequences. A mathematical formulation of the production flow analysis optimization problem was developed for instance by Villa and Bandera [11]. By applying the results of PFA (also called as cluster analysis), a production equipment layout with optimized lines can be modeled. Basic principle of cluster analysis is shown in Fig. 7.

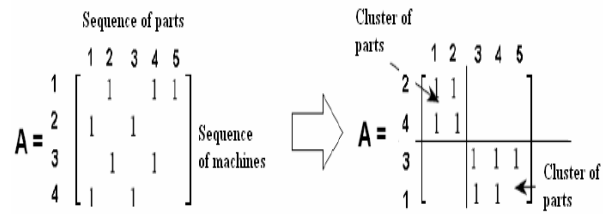

Fig. 7 Simple example of cluster analysis

After gradual transformation of incident matrix “A” that was derived from Table II, it was created a model of production equipment layout with optimized 6 lines that is shown in Fig. 8.

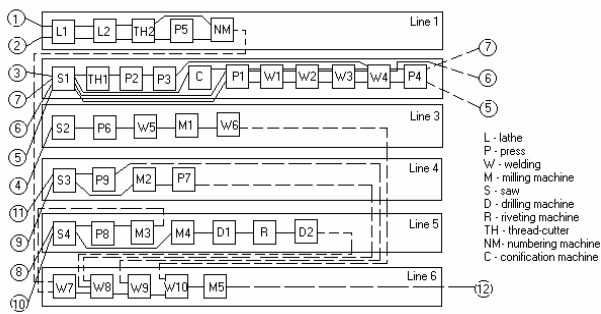

Fig. 8 A new 6-line production equipment layout

In real conditions, the cells are often organized into a U-shaped layout, which is considered appropriate when there is a variation in the workflow among the parts made in the cell. Because it is also actual for the case in mentioned company, redesigned layout (Fig. 9) of production processes consists of lines using U shaped cells. It also allows the multifunctional workers in the cell to move easily in between machines.

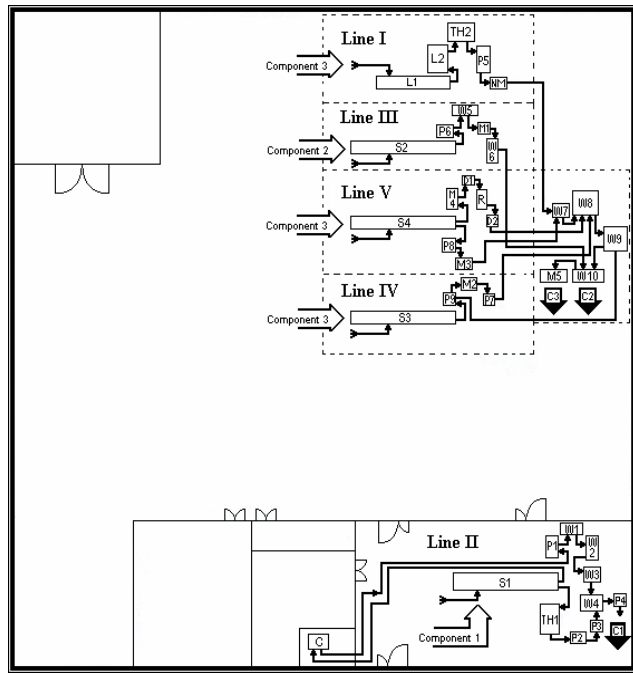

Fig. 9 Product layout disposition after transformation

IV. CONCLUSION

Presented transformation of production process can be viewed as perspective way of optimization of material flows by changing production equipment layout and achieving the goals of company logistics. In generally, material flow optimization belongs among complex engineering and managerial problems, which have not been satisfactorily solved yet. Obviously, this complexity could not be presented in above research in a full scale. Conducting this study from one side helped to verify the effectiveness of decision-making

based on criteria of P-Q analysis. On the other hand, transforming of current production equipment layout to 6 lines led to improvement of more important economical aspects in a company.

ACKNOWLEDGMENT

This paper was partially supported by finance from VEGA Grants No. 1/4153/07.

REFERENCES

- [1] D.M. Lambert, M.C. Cooper, and J. D. Pagh, "Supply Chain Management: Implementation Issues and Research Opportunities." *The international Journal of Logistics Management*, 9, (2), 1998, 1-19.
- [2] M. P. Groover, *Automation, production systems, and computer-integrated manufacturing*. Prentice-Hall, Englewood Cliffs, NJ, 1987.
- [3] A. Robinson, *Continuous Improvement in Automation - a Systematic Approach to Waste Reduction*. Productivity Press, Cambridge, MA, 1991.
- [4] A. Houshyar and G. Peters, "Impact of one piece flow on economic data quality and shop floor data collection." *Journal of the Academy of Business and Economics*, March, 2003.
- [5] S. C. Graves, H. C. Meal, D. Stefek and A. H. Zeghmi, "Scheduling of re-entrant flow-shops." *Journal of Operations Management* 3 (4), 1983, pp. 197-207.
- [6] S. Tsuchiva, *Quality Maintenance: Zero Defects through Equipment Management*, TWI Press, 1997.
- [7] J. L. Burbidge, *Production Flow Analysis for Planning Group Technology*. Clarendon Press, Oxford, UK, 1989.
- [8] K. Sekine, *One Piece Flow: Cell Design for Transforming the Production Process*. Portland, Oregon Productivity Press, 1992
- [9] K. Sekine and K. Arai, *Kaizen for Quick Changeover: Going Beyond SMED*, Productivity Press, Portland, OR, 1992.
- [10] S. A. Irani, *Handbook of Cellular Manufacturing Systems*. New York, John Wiley, 1999
- [11] A. Villa and C. Bandera, "Optimization of Production Flow Patterns by use of Intelligent CAD Tools" *Annals of the CIRP*, Vol. 40/12/1991.

Vladimír Modrák obtained PhD degree in Mechanical Engineering Technology in 1989. Begin with 2003 he is in position of head of Department of Manufacturing Technologies at Technical University of Košice, Faculty of manufacturing Technologies. He became a Full Professor in *Manufacturing Technologies* in 2007.