

Cascaded Neural Network for Internal Temperature Forecasting in Induction Motor

Hidir S. Nogay

Abstract—In this study, two systems were created to predict interior temperature in induction motor. One of them consisted of a simple ANN model which has two layers, ten input parameters and one output parameter. The other one consisted of eight ANN models connected each other as cascaded. Cascaded ANN system has 17 inputs. Main reason of cascaded system being used in this study is to accomplish more accurate estimation by increasing inputs in the ANN system. Cascaded ANN system is compared with simple conventional ANN model to prove mentioned advantages. Dataset was obtained from experimental applications. Small part of the dataset was used to obtain more understandable graphs. Number of data is 329. 30% of the data was used for testing and validation. Test data and validation data were determined for each ANN model separately and reliability of each model was tested. As a result of this study, it has been understood that the cascaded ANN system produced more accurate estimates than conventional ANN model.

Keywords—Cascaded neural network, internal temperature, three-phase induction motor, inverter.

I. INTRODUCTION

THREE-phase induction cage machines are used more than other types of motors in industrial applications involving the conversion of electrical energy to mechanical energy. Therefore, their durability and reliability are important in many industrial processes. Despite the obvious advantages of induction motors, it is necessary to prevent some operational problems from electronic control. Actually, the inverter may produce additional windings harmonic losses and excessive temperatures because of the non-sinusoidal voltage with respect to sinusoidal steady state. Also, harmonic voltages produce magnetic fields, increasing the core losses, vibrations and noise. So, the motor availability could be affected negatively. Depending on the mechanical load applied to the motor shaft and harmonic losses, the internal temperatures of the induction motor can reach dangerous levels.

Overheating of small induction machines causes deterioration of the winding insulation. Therefore, to extend the insulation life, it is very important to monitor the stator winding temperature. In addition, monitoring of the motor winding is a requirement in cases where the motor inadvertently deducted self-cooling capacity and setback in some conditions [1], [2].

Due to the high cost and challenge of constructing thermal sensors, thermal protection relies on fuses and thermal/electronic overload relays that can provide low cost thermal protection for years. But, these devices operate on the crude

temperature forecast due to thermal incompatibilities between thermal components and the thermal characteristics of the motor [2]. When the internal temperature of the machine rises to be higher than the predetermined threshold value, the load of the machine should be reduced or the cooling should be enhanced.

ANN models are very common methods applied to a variety of problems because of their learning capability. The basic goal in an ANN is to minimize the mean square error. For this, the neural network can be trained repeatedly through the dataset [3], [4].

In this study, estimation ability of cascaded ANN model was investigated. Cascaded ANN model consists of eight conventional ANN models. In cascaded system, to obtain more reliable results, each model in the system should forecast own output correctly. In offline ANN systems, to obtain accurate forecasting, dataset that obtained from test set was used for training models. It is accepted that introducing the experimental mechanism to the neural network is depended on the number of input parameters.

The main aim of this study is to answer this question that by increasing the number of input parameters is it possible to obtain a more accurate estimate? Presentation of the experimental system to the network is related directly number of the input parameters. If number of input parameters is great then presentation rate of the experimental system will be great.

II. METHODOLOGY

A. Technical Explanation of ANN

Multilayer feed forward networks, which are generally trained with the back propagation algorithm, are used widely in many fields. The standard network trained by this algorithm is often called BP network as shown in Fig. 1.

ANN design process consists of five steps: Collection of the data, normalizing the data, selecting the ANN architecture and training the model [4], [5].

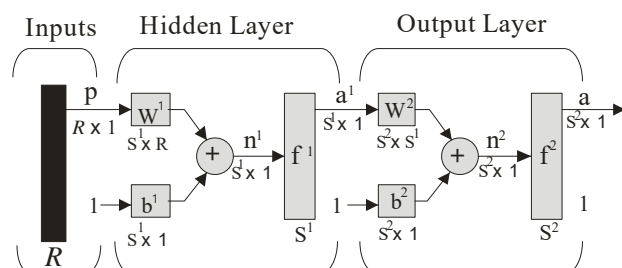

Fig. 1 Two-layers feed forward network

H. S. Nogay is with the Erciyes University, Kayseri, Turkey (phone: +90 505-370-3441; e-mail: nogay@erciyes.edu.tr).

B. Gathering the Data

The experimental setup is shown in Fig. 2. PWM inverter was used in the experiment. PWM inverter has switching frequency with 1 KHz to 15 KHz. Power supply gives output from the PWM 50 Hz, 380 V (RMS) voltage to the induction motor under testing time. All the operating data of the induction motor measured and filed on are transmitted to the computer (PC) by RS-485 for whole analysis. The motor was fixed in turn on a drive bed and loaded with an

electromagnetic brake that powered by the DC power supply. A cooling fan was used in the brake. The squirrel cage induction motor was commercial, three-phase, 1100 W, four-pole and 36-slot.

K-type thermocouples were attached to the stator winding and to a fixed node of the motor respectively in order to measure the intern winding temperature and surface temperature of the motor. The motor was loaded with applied torque of from 1 to 9.74 Nm (full load was 8.18 Nm) [6].

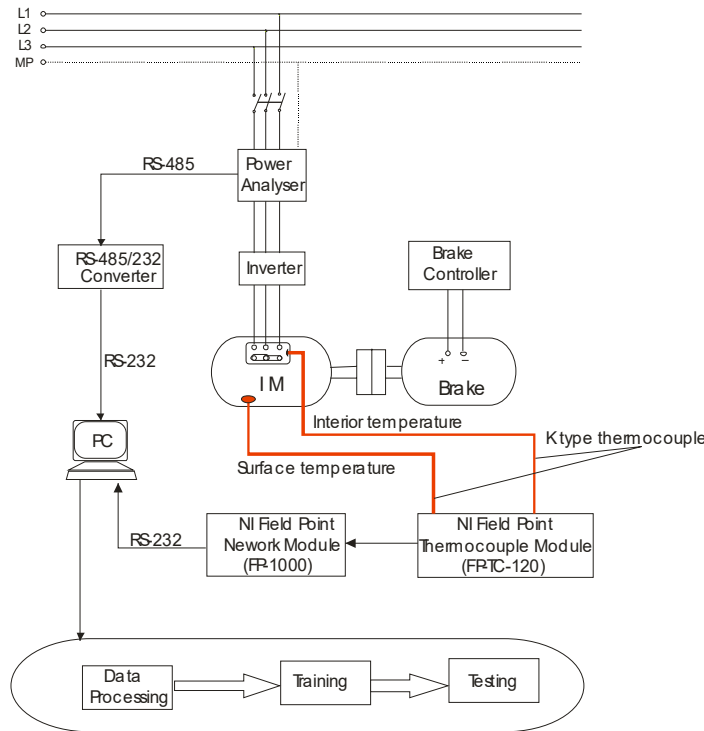

Fig. 2 Experimental Mechanism

C. Conventional ANN Estimation System

A single model is used in the traditional forecasting ANN model. Levenberg – Marquardt learning algorithm was used in the ANN model. In Fig. 3, ANN estimation model used in this study is illustrated. In this model, ten input parameters and one output parameter were used. As shown in Fig. 3, one hidden layer was used. The number of neurons used in the hidden layers (hidden neuron) was selected as 20. For a healthy comparison, number of all hidden neurons were selected as 20. Hyperbolic tangent sigmoid function was used as an activation function in all ANN models. Normalization functions of the all ANN models were used [+1, -1]. Number of data used is 329. 15% of this data was used for testing the network and 15% was used for validation. 70% of the dataset was used for training models. Levenberg – Marquardt learning algorithm was used for all models. Input variables used in this study are phase currents, phase voltages (Phase – Notre), power factor angles and carrier frequency (KHz). Output variable was stator winding interior temperature [7], [8].

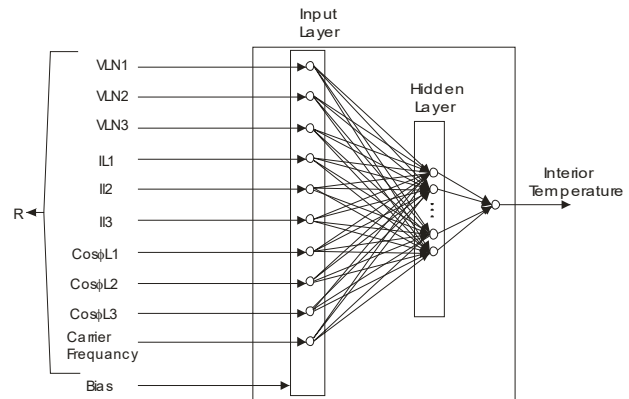

Fig. 3 Conventional ANN Estimation Model

D. Cascaded ANN Estimation System

The cascaded ANN system consists of 8 ANN models connecting to each other. Each ANN output is connected to the next ANN input as an input parameter. Thus, the number

of input parameters in the eighth ANN model is 17. In ANN 8, experimental set up is represented better than other ANN models. Goal of this study is to prove that more accurate estimates can be obtained with increasing the input parameters. One hidden layer was used in all models and all models were trained separately. Construction of each model used for cascaded system is the same with conventional ANN estimating model for quality comparison between

conventional and cascaded system. In Fig. 4, the cascaded system proposed in this study is shown [9], [10].

Ten numbers of input parameters named as R are as follows:

1. Phase Voltages: VLN1, VLN2 and VLN3
2. Phase Currents: IL1, IL2 and IL3
3. Power Coefficients: $\text{Cos}\phi_{L1}$, $\text{Cos}\phi_{L2}$, $\text{Cos}\phi_{L2}$
4. Inverter Carrier Frequency: CF

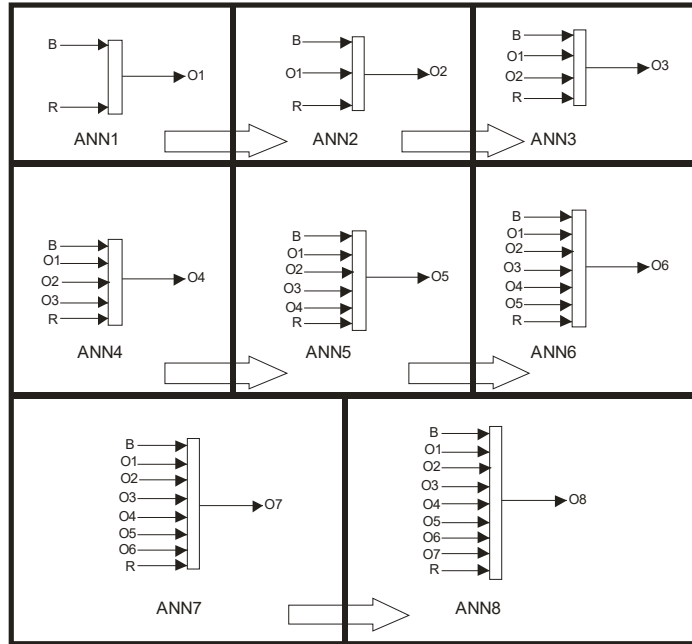

Fig. 4 Proposed ANN System: B: Bias Signal; R: Input Parameters of ANN1; O1: Surface temperature (Co); O2: Current Total Harmonic Distortion (IL1 THD); O3: Current Total Harmonic Distortion (IL2 THD); O4: Current Total Harmonic Distortion (IL3 THD); O5: Voltage Total Harmonic Distortion (VLN1 THD); O6: Voltage Total Harmonic Distortion (VLN2 THD); O7: Voltage Total Harmonic Distortion (VLN3 THD); O8: Interior temperature of induction motor (Co)

TABLE I
RESULTS OF CONVENTIONAL MODEL

	Training	Validation	Testing
Indices	1 x 231	1 x 49	1 x 49
Performance	1.456	1.417	1.946
Regression	0.9425	0.9452	0.9163

III. RESULTS

A. Results of Conventional ANN

In Table I, regression analysis and performance results of the model are shown for training, validation and testing. It is possible to better assess results by examining Tables II and III. In Tables II and III, ANN output and measurement results (target) are illustrated for testing and validation. In Fig. 5, the graph obtained from Tables II and III for testing and validation, difference between output and input is significant. Despite this apparent difference, conventional ANN estimation system produced reliable estimates can be said. The regression analysis results are given in Fig. 6 for training, testing, validation and all. Regression analysis curves as shown in, if the difference between straight lines with dashed lines grows then forecasting ability and performance of ANN will fall. The performance of conventional system was given in Fig. 7. In performance curve, Mean Squared Error (MSE) is the average squared difference between outputs and targets. Low values mean that the error is low. A zero value means that there is no error. In this case, the traditional model can be

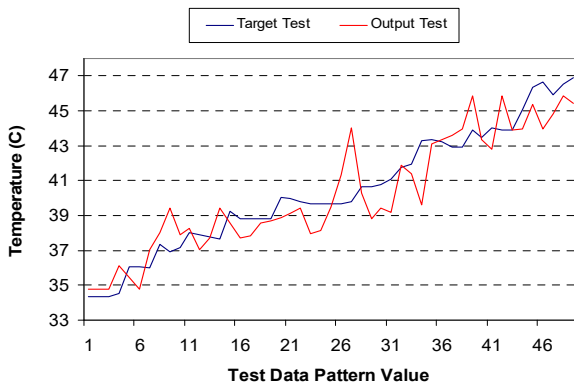

Fig. 5 Comparison of the ANN Test Results and Target

considered successful. The best point of validation at 13th epoch is 1.417.

TABLE II
RESULTS OF TEST AND VALIDATION OF THE CONVENTIONAL MODEL FOR FIRST 24 DATA

Data No	Test		Validation	
	Target	Output	Target	Output
1	34.374	34.794	34.374	34.794
2	34.374	34.794	36.77	37.899
3	34.342	34.794	36.117	34.882
4	34.56	36.14	36.023	37.048
5	36.086	35.428	36.023	36.14
6	36.054	34.794	37.113	38.551
7	36.023	37.048	36.646	35.858
8	37.331	38.025	36.646	37.692
9	36.895	39.404	36.646	36.784
10	37.144	37.921	36.708	37.319
11	38.047	38.282	36.739	37.319
12	37.922	37.048	37.144	36.156
13	37.767	37.744	38.545	37.647
14	37.642	39.439	38.14	38.555
15	39.23	38.581	37.86	37.744
16	38.825	37.743	37.642	37.143
17	38.794	37.834	37.58	37.803
18	38.825	38.578	38.918	38.838
19	38.825	38.689	38.794	38.841
20	40.07	38.869	39.105	37.916
21	40.008	39.142	39.665	37.673
22	39.79	39.448	40.879	39.43
23	39.665	37.935	41.875	40.494
24	39.665	38.143	42.062	41.066

TABLE III
RESULTS OF TEST AND VALIDATION OF THE CONVENTIONAL MODEL FOR SECOND 25 DATA

Data No	Test		Validation	
	Target	Output	Target	Output
25	39.665	39.48	42.156	42.684
26	39.665	41.353	42.809	42.725
27	39.79	44.029	42.996	42.44
28	40.63	40.288	42.872	41.132
29	40.63	38.813	43.401	44.291
30	40.755	39.43	48.786	44.429
31	41.097	39.157	43.619	43.33
32	41.782	41.881	43.463	43.33
33	41.938	41.418	43.37	43.33
34	43.307	39.64	42.934	43.95
35	43.37	43.084	43.089	43.95
36	43.245	43.33	43.121	43.95
37	42.934	43.604	43.712	40.572
38	42.934	43.95	43.961	45.875
39	43.868	45.875	43.432	44.527
40	43.463	43.33	43.619	44.455
41	43.992	42.822	44.397	44.485
42	43.868	45.871	46.949	45.408
43	43.868	43.927	43.868	43.82
44	45.051	43.946	44.21	43.407
45	46.358	45.355	44.21	42.773
46	46.669	43.935	45.237	45.935
47	45.922	44.809	45.237	46.062
48	46.545	45.862	46.358	46.436
49	46.918	45.445	46.389	45.61

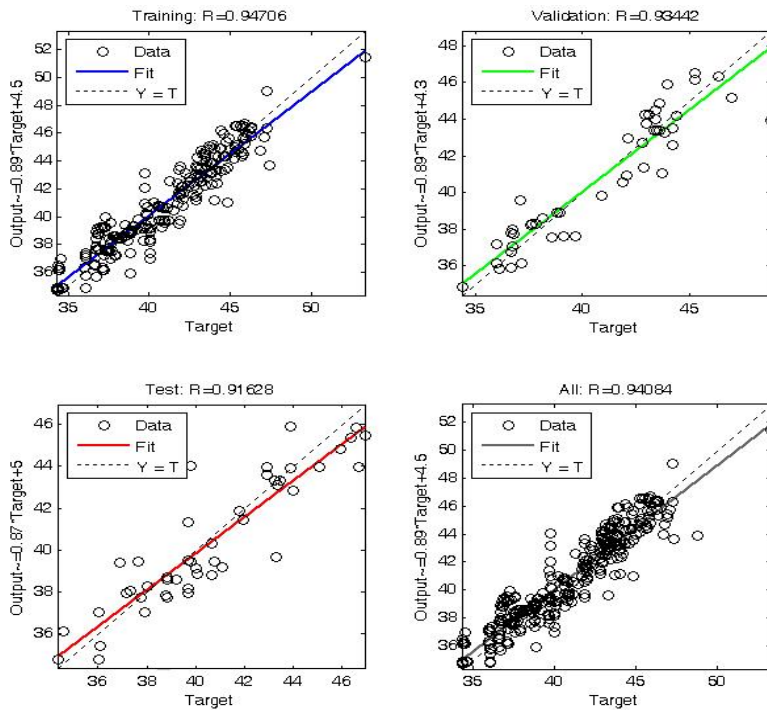

Fig. 6 Regression Graphs of Training, Validation and Testing

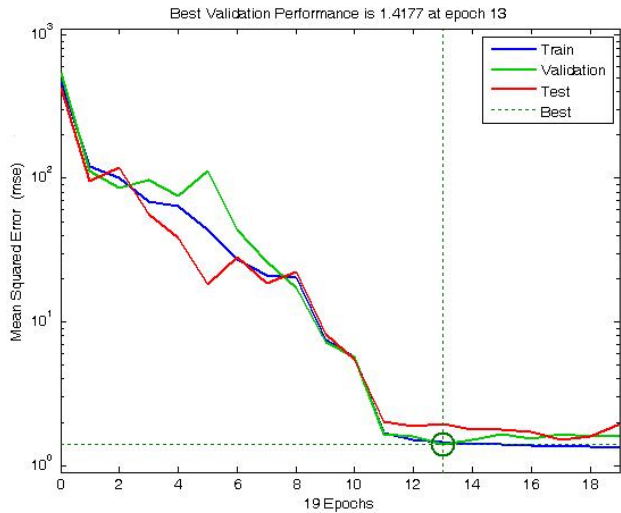

Fig. 7 Performance of the Conventional ANN System

B. Results of Cascaded ANN

Results of cascaded system were given in Table IV. As shown in Table IV, performance of the system is close to zero for validation, training and testing. As in conventional system, in Tables V and VI, estimation results and data used for testing and validation are illustrated. Graph obtained by Tables V and VI was given in Fig. 8. As seen in Fig. 8, the results obtained from cascaded system are excellent. Performance and MSE curve is given in Fig. 9. According to Fig. 9, the best result for validation is 0.22369. In Fig. 10 linear regression analysis results were given. According to regression curves, reliable results were obtained.

TABLE IV
RESULTS OF CASCADED ANN SYSTEM

	Training	Validation	Testing
Indices	1x231	1x49	1x49
Performance	0.0597	0.2237	0.5404
Regression	0.998	0.9907	0.9803

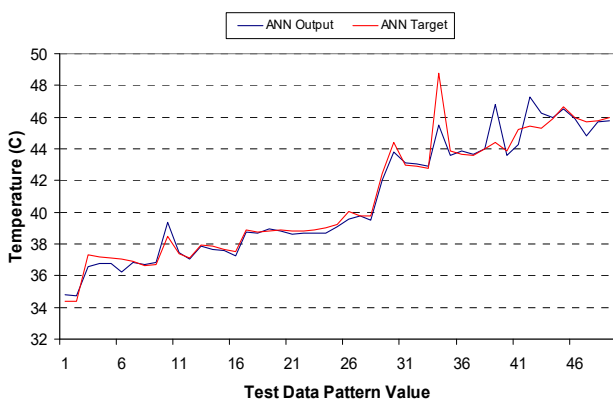

Fig. 8 Comparison of the Cascaded ANN Test Results and Target

TABLE V
RESULTS OF TEST AND VALIDATION OF THE CASCADED SYSTEM FOR FIRST TWENTY FOUR DATA

Data No	Test		Validation	
	Target	Output	Target	Output
1	34.374	34.824	34.342	35.141
2	34.405	34.722	34.374	34.475
3	37.331	36.578	34.56	34.732
4	37.175	36.789	36.926	37.656
5	37.113	36.762	36.926	37.413
6	37.019	36.24	36.117	36.763
7	36.895	36.838	36.086	36.267
8	36.646	36.7	40.008	37.727
9	36.708	36.829	36.895	36.855
10	38.482	39.333	38.047	38.073
11	37.362	37.431	37.673	37.62
12	37.113	37.056	37.331	37.42
13	37.922	37.867	37.206	37.239
14	37.86	37.676	38.545	38.382
15	37.642	37.604	38.358	38.104
16	37.549	37.275	37.922	37.942
17	38.887	38.716	37.767	37.674
18	38.732	38.708	37.642	37.663
19	38.825	38.979	37.642	38.259
20	38.856	38.822	38.918	38.741
21	38.825	38.635	38.794	38.713
22	38.825	38.648	39.665	39.577
23	38.856	38.668	39.759	39.638
24	39.043	38.704	39.883	40.049

TABLE VI
RESULTS OF TEST AND VALIDATION OF THE CASCADED SYSTEM FOR SECOND TWENTY FIVE DATA

Data No	Test		Validation	
	Target	Output	Target	Output
25	39.23	39.09	40.817	41.293
26	40.07	39.573	40.786	40.577
27	39.79	39.745	41.969	42.588
28	39.79	39.528	41.844	42.107
29	42.436	42.051	41.844	41.48
30	44.397	43.828	41.875	42.138
31	42.996	43.082	41.938	42.17
32	42.934	43.016	43.463	43.229
33	42.747	42.893	42.872	42.937
34	48.786	45.491	43.183	43.069
35	43.868	43.593	43.37	43.296
36	43.681	43.88	43.089	42.889
37	43.619	43.648	43.712	43.527
38	43.992	44.016	43.868	43.956
39	44.397	46.77	43.401	43.512
40	43.868	43.582	44.304	45.512
41	45.237	44.249	43.899	43.812
42	45.424	47.262	45.268	45.935
43	45.268	46.253	44.739	45.115
44	45.891	45.976	44.584	44.501
45	46.669	46.547	45.268	45.31
46	45.984	45.925	45.767	45.572
47	45.673	44.851	45.735	45.649
48	45.767	45.698	46.233	46.171
49	45.953	45.77	46.825	46.926

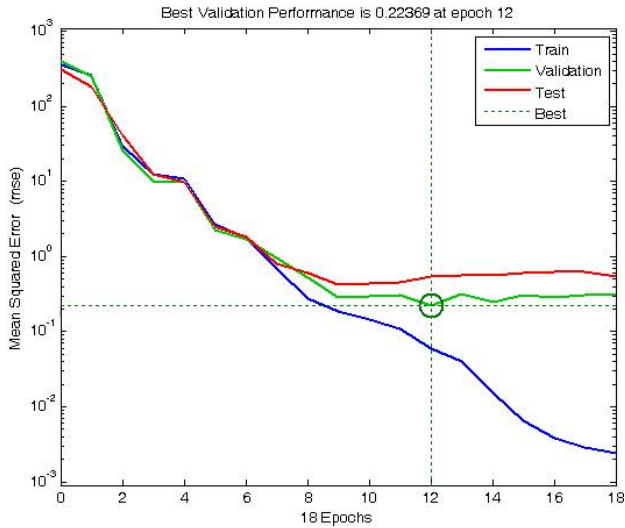

Fig. 9 Performance of the Cascaded ANN System

IV. CONCLUSION

In both systems, an unknown input pattern has been presented to the ANN and the output has been calculated in the testing process. Linear regression between the ANN output and target was performed. In conventional system, target and ANN output values were very related each other. In cascaded model the regression results were more reliable than conventional model. It is obvious from Figs. 9 and 7 that the error decreases rapidly for training, testing and validation and then remains almost constant in iteration 18 for cascaded and in iteration 13 for conventional system respectively. The comparison of the two systems was given in Fig. 11. In Fig. 12, the comparison of these systems was performed for first 50 data to be more understandable.

The results have shown that the prediction error obtained by cascaded ANN system is very plausible. So the cascaded ANN system produces reliable estimates of interior temperature of induction motors. The results have also pointed out that ANN can implement many other data prediction efforts easily and successfully.

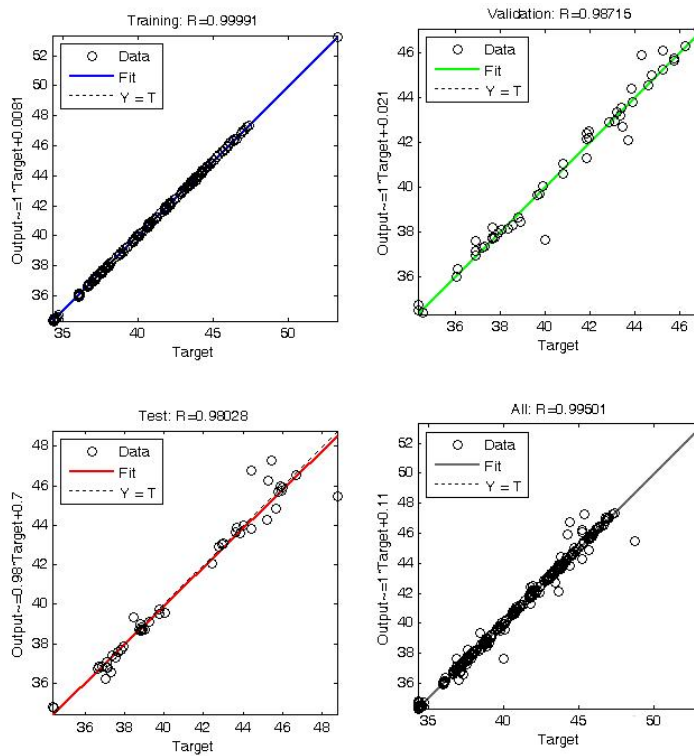

Fig. 10 Regression Graphs of Training, Validation and Testing For Cascaded ANN

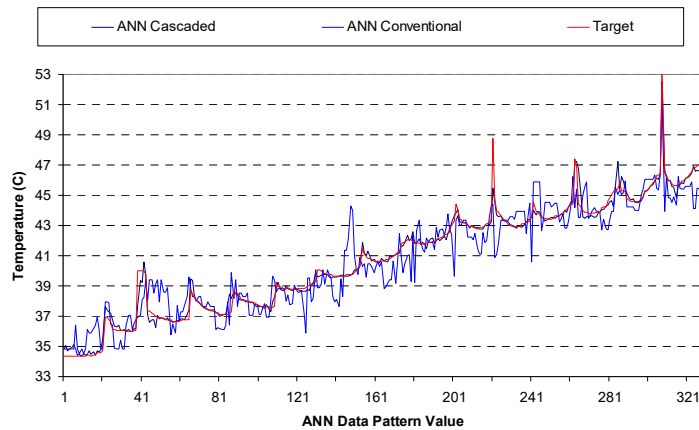

Fig. 11 Comparison of the Conventional System and Cascaded System

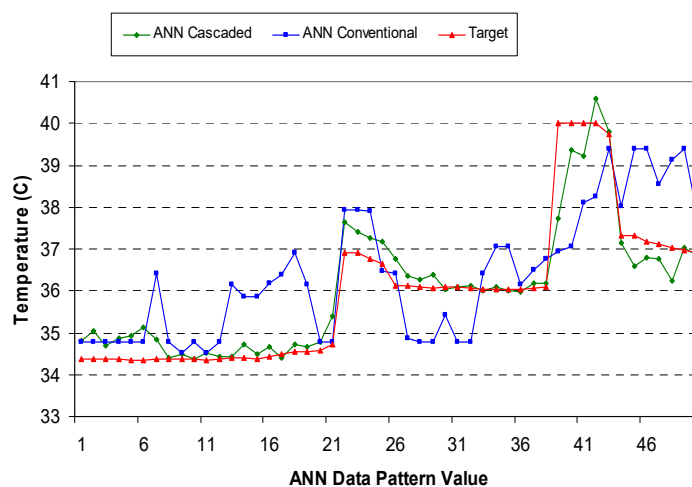

Fig. 12 Comparison of the Conventional System and Cascaded System for 50 Data

REFERENCES

- [1] G. E. P. Box, G. Jenkins, *Time Series Analysis, Forecasting and Control*, Golden-Day, San Francisco, CA, 1970.
- [2] T. M Hagan, H. B. Demuth, M. Beale, *Neural Network Design*, PWS Publishing Company, 1996, 2-44.
- [3] H. S. Nogay, Y. Birbir, "Designation of Harmonic Estimation ANN Model Using Experimental Data Obtained From Different Produced Induction Motors", 9th WSEAS Int. Conf. on Neural Networks (NN' 08), Sofia, Bulgaria, May., 2 - 4, (2008).
- [4] N. Amjady, F. Keynia, "Day-ahead price forecasting of electricity markets by a new feature selection algorithm and cascaded neural network technique", *Energy Conversion and*
- [5] D. H. Hwang, K. C. Lee, Y. J. Kim, Y. J. Lee, M. H. Kim, D. H. Kim, "Analysis of Voltage Distribution in Stator Winding of IGBT PWM Inverter-Fed Induction Motors", IEEE ISIE 2005, June 20-23, Dubrovnik, Croatia, 2005.
- [6] P. Gnacinski, "Effect of unbalanced voltage on windings temperature, operational life and load carrying capacity of induction machine", *Energy Conversion and Management*, 49 (2008) 761-770.
- [7] B. H. Ertan, M. Y. Uçtuğ, *Modern Electrical Drives*, Springer - Verlag, New York, USA, 2000
- [8] S. Lee, G. Habetler, G. Harley and D. Gritter, "An Evaluation of Model-Based Stator Resistance Estimation for Induction Motor Stator Winding Temperature Monitoring", *IEEE Transactions on Energy Conversion*, Vol. 17, No:1 March 2002
- [9] F. Malik, M. Nasereddin, "Forecasting output using oil prices: A cascaded artificial neural network approach", *Journal of Economics and Business*, 58 (2006) 168-180
- [10] Jani J.T., M. I. Lehtokangas, J. P. P. Saarinen, "Evaluation of constructive neural networks with cascaded architectures", *Neurocomputing*, 48 (2002) 573-607.

Hüdr S. Nogay (M' 75) was born in Isparta, Turkey. He received the B.S. and M.S degrees from the University of Marmara, Istanbul, Turkey. Since 2015, she is a Lecturer with the Erciyes University. His research interests are in Electrical Machines, Renewable Energy and Artificial Intelligence.