

BIP-Based Alarm Declaration and Clearing in SONET Networks Employing Automatic Protection Switching

Vitalice K. Oduol and Cemal Ardil

Abstract—The paper examines the performance of bit-interleaved parity (BIP) methods in error rate monitoring, and in declaration and clearing of alarms in those transport networks that employ automatic protection switching (APS). The BIP-based error rate monitoring is attractive for its simplicity and ease of implementation. The BIP-based results are compared with exact results and are found to declare the alarms too late, and to clear the alarms too early. It is concluded that the standards development and systems implementation should take into account the fact of early clearing and late declaration of alarms. The window parameters defining the detection and clearing thresholds should be set so as to build sufficient hysteresis into the system to ensure that BIP-based implementations yield acceptable performance results.

Keywords—Automatic protection switching, bit interleaved parity, excessive bit error rate

I. INTRODUCTION

THIS paper examines the performance of bit-interleaved parity (BIP) methods in error rate monitoring, especially for high bit error rates. The term high here is relative. For example, when the BIP calculation is taken over 801 frames, a bit error rate (BER) greater than 10^{-3} is high, in that for values of BER above this level there is noticeable disparity between the BIP-based and exact probabilities of bit error in the BIP word. When the number of frames is 9720 the transition level is at a BER of 2×10^{-3} , and so on. The reason for this is given by (3) and (4) and depicted in Fig.4. The analysis presented here can be applied in SONET systems employing automatic protection switching (APS). Technical standards exist that specify requirements (and objectives) for declaring and clearing alarms. Details of SONET frame structure and automatic protection switching can be found in telecommunication standards [1-4] and other texts [5-8].

The protection mechanism can be of two types [6], the 1:1 and 1:n protection mechanisms. Fig.1 (a) depicts the 1:1 protection architecture where a protection interface is paired with each working interface. Fig.1 (b) depicts the other the 1:n protection architecture, consisting of a single protection facility for several working interfaces. In either case, when a working interface fails, traffic is automatically switched over to the protection interface. The failed working facility is marked with an \times in both halves of Fig.1.

V. K. Oduol is with the Department of Electrical and Information Engineering, University of Nairobi, Nairobi, Kenya (+254-02-318262 ext.28327, vkoduol@uonbi.ac.ke)
Cemal Ardil is with the National Academy of Aviation, Baku, Azerbaijan

The SONET STS-1 frame structure is given in Fig.A1 of the Appendix. For the purposes of this paper, the bytes of interest are the three BIP bytes B1, B2 and B3 whose scopes are as follows. The B1 byte is used to detect parity errors per frame. This is done for the first STS-1 frame in the STS-n multiplexed frame. It monitors section level bit errors. The B2 byte is used to monitor line-level bit errors, and the B3 byte is used to monitor path-level bit errors, inclusive of the path overhead.

A single interleaved parity byte is used to provide error monitoring across a particular segment along the end-to-end SONET path. This parity byte performs a parity check on the previous Synchronous Transport Signal level 1 (STS-1) frame. During the parity check, the first bit of the BIP octet is a parity check on the first bit of all octets of the previously scrambled STS-1 frame. The second bit of the BIP octet is used exactly the same way, i.e. it is a parity check on the second bits of each octet of the previous STS-1 frames, and similarly for the other bits.

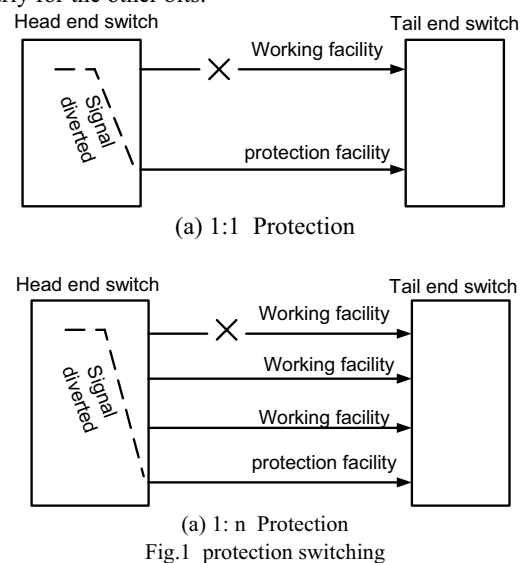

When the bit errors exceed certain thresholds, i.e. when there is an excessive bit error rate condition, the system may declare an alarm. These conditions when present must be declared within time limits specified by telecommunication standards [1,3]. The rest of the paper is organized as follows: Section II presents a discussion and determination of the bit error probability in the BIP word. Section III presents the declaration of the alarm using a sliding window, where first

the window containing the alarm is determined, and then the alarm is located within the window. Section IV discusses the clearing of the alarm. In a manner parallel to the declaration of the alarm, the window containing the alarm clear condition is first determined, then the alarm clear location is found within the window. Section IV presents the results and conclusions. Furthermore, the Appendix provides some information about the SONET STS-1 frame and some pertinent BIP count parameters.

II. BIT ERROR PROBABILITY IN A BIP WORD

Fig.2. shows the bytes to be included in the computation of the bit interleaved parity (BIP) byte. The bit error for the bit in the second position is registered only if there is a total of an odd number of errors in the bits considered. If there is only one byte to consider, the probability that there is a bit error in the second bit position is p . Suppose $N-1$ bytes have been considered so far.

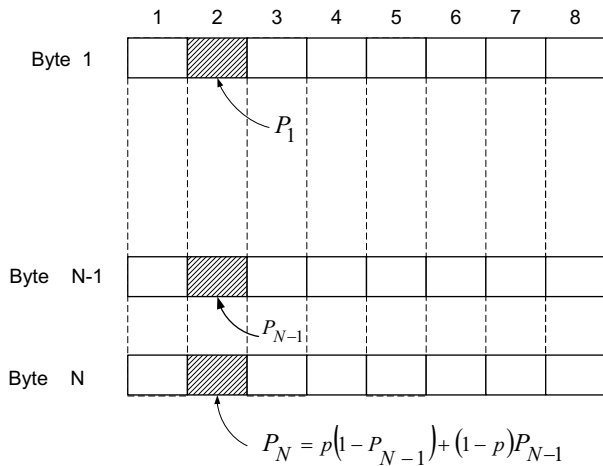

Fig. 2 Bit interleaved parity probability of bit error for the bit in the second position of the BIP word

The probability P_N that that a bit error is registered for the second position is obtained by considering two disjoint events. Either there is an error at the end of the previous stage ($N-1$) and no error in byte- N or there is no error at the end of the previous stage and an error at byte- N . These two give rise to the equation

$$P_N = p_{N-1}(1 - p) + (1 - p_{N-1})p \tag{1}$$

which is quickly rearranged as

$$P_N = (1 - 2p)p_{N-1} + p \tag{2}$$

with the initial condition that $P_0 = 0$.

It is easily verified that the solution to the above equation is

$$P_N = \frac{1}{2} [1 - (1 - 2p)^N] \tag{3}$$

Here N is the number of bits included in the calculation. The exact bit error probability considers that there are N bits and the probability of bit error is then the complement of the probability of no bit error in any of the second position bits. Accordingly the exact probability that a bit in the BIP word is

registered as being in error is given by

$$P_{Exact} = 1 - (1 - p)^N \tag{4}$$

In addition to the N bytes included in (3) and (4) there is further potential for bit errors in the BIP byte of the current frame. This is compared with a calculated version of the BIP byte. Thus there are $N+1$ bytes to included in (3) and (4). These equations are compared in Fig.3 for some typical values of N listed in Table AI.

For $N=801$, the BIP-based (3) and the exact (4) values begin to diverge at a bit error rate of 2×10^{-4} , with the BIP-based value settling at 0.5, and the exact one at 1.0. This trend is seen for the other values of N . Indeed the point of separation of the two values gets smaller as N increases, but for all the cases, the exact traces go to 1.0 whereas the BIP-based trace goes to 0.5. These can be derived from the expressions already given by letting p tend to 1 in (3) and (4), respectively.

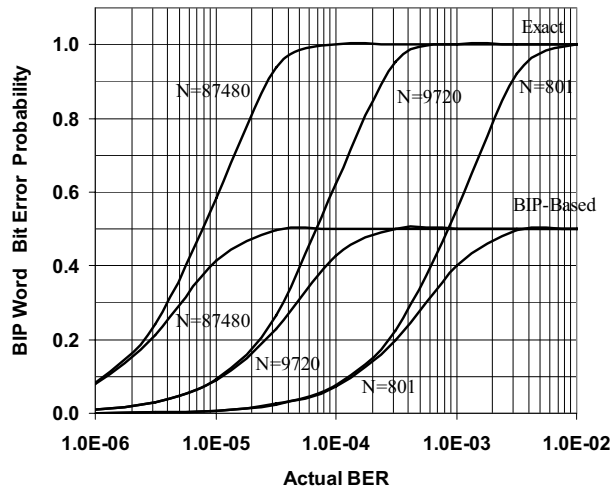

Fig. 3 Variation of BIP word bit error probability with the number of bits used in the BIP calculation. Traces for three values of N are shown

It is also observed that as N increases, the curves in Fig.3 shift towards the left, the BIP-based traces approaching a limit of 0.5, and the “exact” traces approach unity. Despite the above disparity of (3) and (4), it is possible to obtain working bit error rate monitoring methods based on BIP calculations using a window of an appropriate size and two thresholds one for declaring alarm, and the other for clearing.

A frame is considered “errored” when it has more than one bit error in the BIP byte. The probability P_{FE} that a frame is errored is then

$$P_{FE} = \sum_{m=2}^8 \binom{8}{m} (1 - P_{N+1})^{8-m} P_{N+1}^m \tag{5}$$

A window of size M frames is used and an alarm is declared if there are N_1 or more errored frames in the window. Conversely, once an alarm is declared the alarm is cleared when there are N_2 or more non-errored frames in a window of size M frames. Alarm declaration and clearing is cyclic

process which consists of four stages as shown in Fig.5. The analysis uses a sliding window in monitoring the BIP bit errors. A sliding window has many advantages over a jumping window. It is therefore widely used in many standard network protocols, and several authors[9-12] have provided recent analysis of the performance protocols based on sliding windows.

For the present objective, a sliding window will have the advantage over a jumping window in that the spread of the errors may traverse the boundary of a window, and a jumping window will fail to catch some of those error patterns that lie on the window boundaries. A sliding window, on the other hand will not miss such error patterns.

Returning to Fig.4, it is evident that first there is a hunt for the window containing the alarm, then the alarm is declared within the window. For clearing the alarm, there is a hunt for the window containing the alarm clear, followed by locating the alarm clear condition within the window. This cyclic process is repeated for as long as the system runs, being restarted only when the bit error estimates dictate that the window parameters M, N₁ and N₂ should be changed. The detailed descriptions of the components of Fig.3 are given in the sections that follow.

III. ALARM DECLARATION

The unconditional event that a window contains an alarm is equivalent to the event that there are at least N₁ errored frames in a window of size M. This gives the probability P_{Declr} of alarm declaration as

$$P_{Declr} = \sum_{m=N_1}^M \binom{M}{m} P_{FE}^m (1 - P_{FE})^{M-m} \tag{6}$$

To locate, declare and clear alarms, the implementation of the bit error rate monitoring uses a sliding window as depicted in Fig.4.

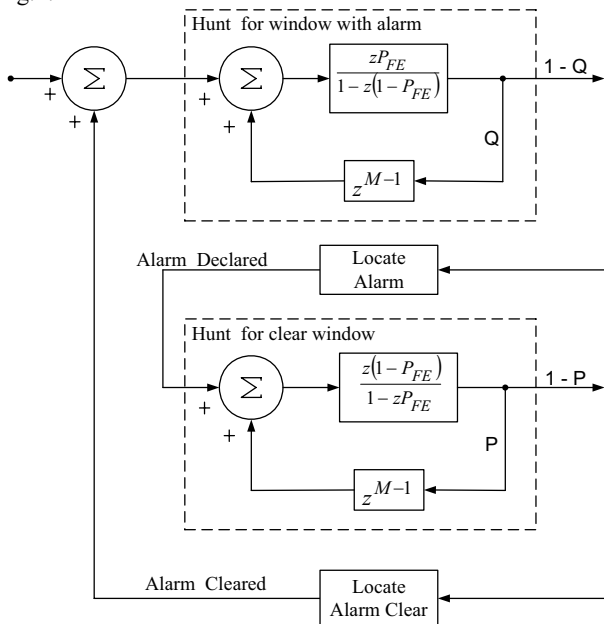

Fig. 4 Alarm declaration and clearing

The process involves first hunting for the window containing the alarm, followed by locating the alarm within the window. The first block after the summing point represents the fact that the system waits for the occurrence of an “errored” frame.

The length K_D of time in frames up to and including the errored frame is a geometrically distributed random variable satisfying the distribution

$$\text{Prob} \{K_D = k\} = P_{FE}(1 - P_{FE})^{k-1} \quad k \geq 1 \tag{7}$$

whose moment generating function P_{KD}(z) is

$$P_{KD}(z) = \frac{zP_{FE}}{1 - z(1 - P_{FE})} \tag{8}$$

Once the first errored frame is found, the system examines the subsequent frames keeping two counts, the number of frames examined, and the accumulated number of errored frames so far. If the number of frames reaches the window size before the number of errored frames reaches the threshold N₁, the search begins afresh. This is the event that there are fewer than N₁-1 errored frames in a window of size M-1, where appropriate allowance has been made for the fact that one errored frame occurs at the beginning of the target window. Thus the probability Q that the search begins afresh is then given by

$$Q = \sum_{m=0}^{N_1-2} \binom{M-1}{m} (1 - P_{FE})^{M-m-1} P_{FE}^m \tag{9}$$

If the search results in locating the window with alarm, then point at which the alarm is declared has to be determined. There is no need to examine the whole window if the required number of errored frames has been reached. Thus the length of time to the declaration of the alarm is another random variable.

A. Waiting Time to Reach Window Containing Alarm

At this point it is reasonable to obtain an expression for the waiting time to the window containing the alarm. This is done via its moment generating function T_{WD}(z). The feedback diagram of Fig.4 can be used to give

$$T_{WD}(z) = \frac{z(1-Q)P_{FE}}{1 - z(1 - P_{FE}) - z^M Q P_{FE}} \tag{10}$$

It is noted that for z = 1, the denominator of this expression is zero for Q = 1. The quantity in (10) being a moment generating function is required to be analytic inside and on the unit disc { z: |z| ≤ 1 }. This requirement will be violated for Q = 1. Indeed, the mean time to the alarm window which is obtained as

$$\left. \frac{d}{dz} (T_{WD}(z)) \right|_{z=1} = \frac{1 + (M-1)QP_{FE}}{(1-Q)P_{FE}} \tag{11}$$

reveals that for values of Q close to 1, the system waiting time on average will be unacceptably large. Thus, the window parameters M and N₁ of the system must be chosen to ensure that Q is far enough away from 1. The observations made on (10) and (11) are a consequence of the sliding window

mechanism; it remains to be seen if the BIP calculations are sensitive to this fact. This is deferred to the results presented later.

B. Locating the Alarm Within Window

At this point the window containing the alarm has been found. An accumulated count is kept within the window the errored frames, and the alarm is declared as soon as the number of errored frames reaches the threshold N_1 ; there is no need to reach the end of the window. This is done in the block containing the moment generating function $T_D(z)$ in Fig.4. The probability $P_{Declr}(j)$ of declaring an alarm after j frames is the event that in the preceding $j-1$ frames there are N_1-2 errored frames, followed by an errored frame. The probability of this event is then

$$P_{Declr}(j) = \binom{j-1}{N_1-2} P_{FE}^{N_1-1} (1-P_{FE})^{j-N_1+1} \quad (12)$$

To obtain the probability of an alarm declaration the expression in (12) can be summed for $j = N_1-1$ to $M-1$, and incorporating a multiplying factor to cater for the fact that (12) is a conditional probability. This is a much longer method than the expression given in (6), which considers that there at least N_1 errored frames in the window for the alarm to be declared.

Given that the window containing the alarm has been located, the remaining waiting time T_D to alarm declaration is then given via its moment generating $T_D(z)$ as

$$T_D(z) = \sum_{j=N_1-1}^{M-1} \binom{j-1}{N_1-2} P_{FE}^{N_1-1} (1-P_{FE})^{j-N_1+1} z^j \quad (13)$$

The random variables T_{WD} and T_D referred to in (10) and (13), respectively, are statistically independent. The total time T_1 to declare the alarm is the sum of these two.

$$T_1 = \left. \frac{d}{dz} (T_{WD}(z)) \right|_{z=1} + \left. \frac{d}{dz} (T_D(z)) \right|_{z=1} \quad (14)$$

Substituting (10) and (13) in (14) gives the mean alarm declaration time as

$$T_1 = \frac{1+(M-1)QP_{FE}}{(1-Q)P_{FE}} + (N_1-1) \sum_{j=N_1-1}^{M-1} B(N_1-1, j, P_{FE}) \quad (15)$$

where $B(N_1-1, j, P_{FE})$ is the binomial probability of N_1-1 successes in j Bernoulli trials, and P_{FE} is the probability of success. This quantity along with the corresponding one for clearing of the alarm can be evaluated for different system parameters.

IV. ALARM CLEARING

The unconditional probability that a window of size M contains an alarm clear condition is equivalent to the event that there are *at least* N_2 non-errored frames in a window of size M . In an analogous manner to (6), this gives the probability of alarm clearing as

$$P_{Clear} = \sum_{m=N_2}^M \binom{M}{m} P_{FE}^{M-m} (1-P_{FE})^m \quad (16)$$

The same sliding window above is used in the bit error rate monitoring to locate the condition to clear the alarm. This

section is very similar to the preceding one, the difference being that whereas the hunt for the alarm counts the errored frames, here it is the non-errored frames that are counted, and the parameter N_1 is now replaced by N_2 . With reference to Fig.4, the parameter P_{FE} is replaced by $1-P_{FE}$, and Q is replaced by P , defined similar to (9) as

$$P = \sum_{m=0}^{N_2-2} \binom{M-1}{m} P_{FE}^{M-m-1} (1-P_{FE})^m \quad (17)$$

and is the probability that there are fewer than N_2-1 non-errored frames in the window of size $M-1$. As before the length K_C of time in frames up to and including the terminating non-errored frame is a geometrically distributed random variable satisfying the distribution

$$\text{Prob} \{K_C = k\} = (1-P_{FE}) P_{FE}^{k-1} \quad k \geq 1 \quad (18)$$

whose moment generating $P_{KC}(z)$ is

$$P_{KC}(z) = \frac{z(1-P_{FE})}{1-zP_{FE}} \quad (19)$$

with the corresponding one for clearing of the alarm, is evaluated for different system parameters.

A. Waiting Time to Reach Window To Clear Alarm

Exploiting the similarity with the preceding development, the waiting time T_{WC} in frames required to reach the window is defined via its moment generating function $T_{WC}(z)$ as

$$T_{WC}(z) = \frac{z(1-P)(1-P_{FE})}{1-zP_{FE}-z^M P(1-P_{FE})} \quad (18)$$

The mean time to the clear window is obtained as

$$\left. \frac{d}{dz} (T_{WC}(z)) \right|_{z=1} = \frac{1+(M-1)P(1-P_{FE})}{(1-P)(1-P_{FE})} \quad (19)$$

As before, it also holds here that for values of P close to 1, the system waiting time on average will be unacceptably large, which underscores once more the fact that the window parameters M and N_2 must be chosen to ensure that P is far enough away from 1.

B. Locating the Alarm Clear Within Window

The window containing the alarm clear condition having been located, the alarm clear is indicated as soon as the number of non-errored frames reaches the threshold N_2 ; there is no need to reach the end of the window. The probability $P_{Clear}(j)$ of clearing an alarm after j frames is the event that in the preceding $j-1$ frames there are N_2-2 non-errored frames, followed by a non-errored frame. The probability of this event is then

$$P_{Clear}(j) = \binom{j-1}{N_2-2} P_{FE}^{j-N_2+1} (1-P_{FE})^{N_2-1} \quad (20)$$

The probability that an alarm is cleared within the window can be obtained by summing the above for $j = N_2-1$ to $M-1$. That is

$$P_{Clear} = \sum_{j=N_2-1}^{M-1} P_{Clear}(j) \quad (21)$$

The expressions in (16) and (21) are equivalent since they

refer to the same events. The results provided here are obtained based on (16). In practice the parameters M, N₁ and N₂ are chosen to ensure that the declaration and clearing probabilities meet certain requirements established by applicable telecommunication standards such as [1] and [3].

Having located the window containing the alarm clear, the next task is to locate the alarm clear within the window. The remaining waiting time T_C to alarm clearing is then given via its moment generating T_C(z) as

$$T_C(z) = \sum_{j=N_2-1}^{M-1} \binom{j-1}{N_2-2} P_{FE}^{N_2-1} (1-P_{FE})^{j-N_2+1} z^j \quad (22)$$

The total time to clear the alarm T₂ is the sum of these two

$$T_2 = \left. \frac{d}{dz} (T_{WC}(z)) \right|_{z=1} + \left. \frac{d}{dz} (T_C(z)) \right|_{z=1} \quad (23)$$

Substituting (18) and (22) in (23) gives the mean time in frames to alarm clearing as

$$T_2 = \frac{1+(M-1)P(1-P_{FE})}{(1-P)(1-P_{FE})} + (N_2-1) \sum_{j=N_2-1}^{M-1} B(N_2-1, j, 1-P_{FE}) \quad (24)$$

where B(N₁-1, j, 1-P_{FE}) is the binomial probability of N₂-1 successes in j trials, and 1-P_{FE} is the probability of success. This quantity along with the corresponding one for the declaration of the alarm can be evaluated for different system parameters and the results compared for both the BIP-based and exact methods. Rather than clutter the presentation with too many results, only those corresponding to N=801 are given here.

V. RESULTS AND CONCLUSION

From Fig.4 it has already been observed that the two expressions (3) and (4) for the bit error probability in the BIP byte deviate as the prevailing bit error rate increases, giving the first indication that the BIP-based results may differ from the actual situation. When the bit error rate is low, the deviation is small. The onset of deviation depends on, and decreases with, the number N of frames used in the BIP calculation. The sliding window parameters N = 801, M = 64, N₁ = 49, and N₂ = 13 were used to generate the results presented here. Table I and Fig.5 give the results for the declaration times in seconds for sliding window parameters indicated.

TABLE I
ALARM DECLARATION TIMES FOR N = 801

BER	Declaration Times [s]	
	BIP-Based	Exact
1.00E-04	1.0101E+17	1.2602E+13
1.78E-04	7.5248E+13	7.9066E+11
3.16E-04	6.6743E+02	7.6287E+00
5.62E-04	1.4502E-02	6.1729E-03
1.00E-03	6.1415E-03	6.1272E-03
1.78E-03	6.1315E-03	6.1250E-03
3.16E-03	6.1297E-03	6.1250E-03
5.62E-03	6.1296E-03	6.1250E-03
1.00E-02	6.1296E-03	6.1250E-03

The declaration times while compliant with the requirements

of the telecommunication standards, show a deviation. For example when BER = 5.62 × 10⁻⁴ the declaration times are 14.502 ms (BIP) and 6.17 ms (exact). This indicates that the BIP-based system declares the alarm later than should be case.

This poses a challenge to the standards developers to ensure that the alarm declaration thresholds are set so that even though the alarm are set later the results can still be used to guarantee acceptable network performance .

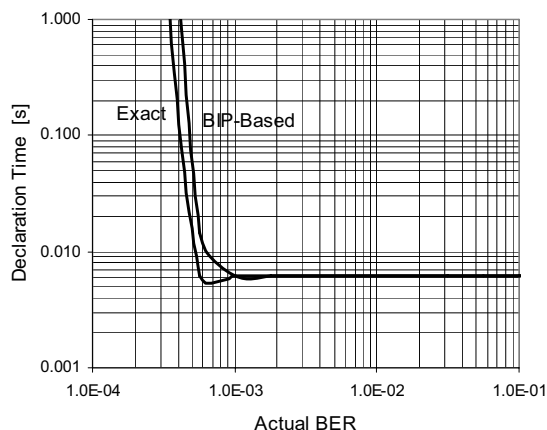

Fig. 5 Alarm declaration times for N = 801

Table II and Fig.6 give the alarm clearing times. Evident from these results is the fact that the clearing times higher values of the bit error rate are much lower for the BIP-based sliding window that those obtained by the exact calculations. Indeed for BER = 1.78 × 10⁻³ the clearing times are 186.424 seconds (BIP) and 7894.36 seconds (exact). This indicates that the BIP-based system clears the alarm too soon. Whereas the exact calculation indicates a clearing time of over 2 hours, the BIP-based version clears the alarm in just over 3 minutes.

TABLE II
ALARM CLEARING TIMES FOR N = 801

BER	Clearing Times [s]	
	BIP-Based	Exact
1.00E-04	6.13184E-03	6.12400E-03
1.78E-04	1.77828E-03	1.55730E-03
3.16E-04	2.47037E-04	2.87339E-04
5.62E-04	1.15087E-03	1.52998E-03
1.00E-03	2.65636E-01	4.44014E-01
1.78E-03	1.86424E+02	7.89436E+03
3.16E-03	4.27356E+03	3.34928E+08
5.62E-03	6.35641E+03	4.92620E+14
1.00E-02	6.40483E+03	2.79511E+25

The scenario presented here is that the BIP-based result indicates an alarm declaration later and clears the alarm too soon. The sliding window algorithm to be established to take into account the fact that there may be delayed declaration and false clearing of the alarms. Fortunately, the standards developers have built some hysteresis into the requirements [1] to guard against false clearing.

The benefits of the analysis are to the standards developers

who must set the requirements to ensure that when BIP-based error monitoring is employed there will be disparities with the exact results. For the implementers of the network elements, the analysis presented here will be useful in setting the sliding window system parameters, to ensure that acceptable performance is achieved.

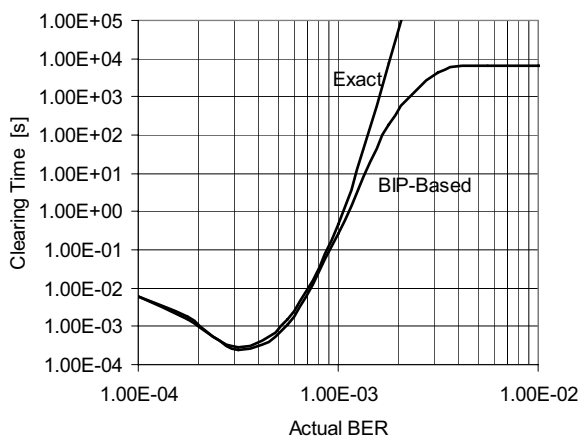

Fig. 6 Alarm clearing times for N=801

APPENDIX

Fig.A1 shows the SONET STS-1 frame indicating the overhead bytes and their functions. Table AI shows the values of the number of frames used in the BIP calculations. The data in this table can be used together with (3) and (4) to obtain the probability that a bit in the BIP word is indicated as being in error.

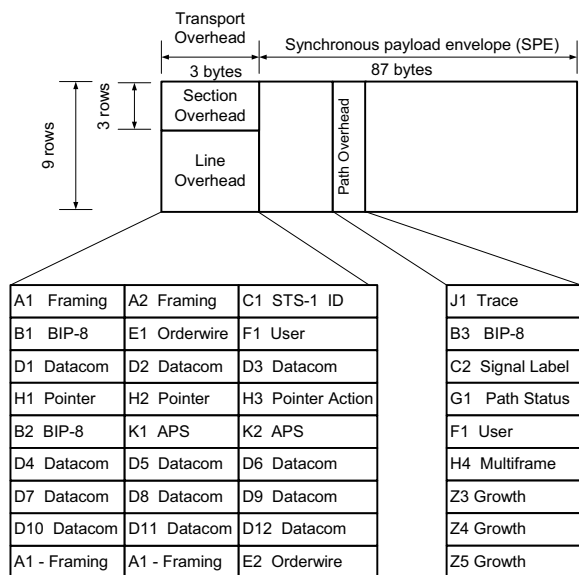

Fig. A1 SONET STS-1 Overhead bytes and their functions

TABLE AI.
BIP COUNT PARAMETERS

BIP Type	Signal	N
B1	STM-0 / STS-1	810
B1	STM-1 / STS-3	2,430
B1	STM-4 / STS-12	9,720
B1	STM-12 / STS-48	29,160
B1	STM-48 / STS-192	87,480
B2	All signals	801
B3	VC-3 / STS-1	783
B3	VC-4 / STS-3c	2,349

REFERENCES

- [1] SONET Transport Systems; Common Generic Criteria, Bellcore publication GR-253 CORE, Section 5.3
- [2] ANSI T1.105: SONET - Basic Description including Multiplex Structure, Rates and Formats
- [3] ANSI T1.105.01: SONET - Automatic Protection Switching
- [4] ANSI T1.105.07: SONET - Sub-STS-1 Interface Rates and Formats Specification
- [5] International Engineering Consortium, "SONET Tutorial", Available <http://www.iec.org/online/tutorials/sonet/topic03.asp>
- [6] U. Black, S. Waters, *Sonet and T1: Architectures for Digital Transport Networks*, 2nd ed, Prentice Hall, 2005
- [7] M.N. Ellanti, S.S. Gorshe, L.G. Raman, W.D. Grover, *Next Generation Transport Networks: Data, Mmanagement, and Control Planes*, Springer, 2005
- [8] H. G. Perros, *Connection-Oriented Networks: SONET/SDH, ATM, MPLS, and Optical Networks*, Wiley 2005
- [9] D. Chkhaev, J. Hooman, E. de Vink, "Formal Verification of an Improved Sliding Window Protocol" in *Proc. 3rd Progress Symposium on Embedded Systems*, 2002, Utrecht, The Netherlands, October 2002, pages 77-82.
- [10] Mark A. Smith and Nils Klarlund. Verification of a Sliding Window Protocol Using IOA and MONA. FORTE/PSTV 2000, Pisa, Italy, October 2000, pages 19-34.
- [11] Eric Madelaine and Didier Vergamini. Specification and Verification of a Sliding Window Protocol in LOTOS. FORTE '91, Sydney, Australia, November 1991, pages 495-510.
- [12] Y. Deng, Z. Huang, "Modeling and Performance Analysis of a Sliding Window Protocol" *Proc. 4th Progress Symposium on Embedded Systems*, pp. 60-65, Utrecht, STW, The Netherlands October 2003

Vitalice K. Oduol received his pre-university education at Alliance High School in Kenya. In 1981 he was awarded a CIDA scholarship to study electrical engineering at McGill University, Canada, where he received the B.Eng. (Hons.) and M.Eng. degrees in 1985 and 1987, respectively, both in electrical engineering. In June 1992, he received the Ph.D. degree in electrical engineering at McGill University.

He was a research associate and teaching assistant while a graduate student at McGill University. He joined MPB Technologies, Inc. in 1989, where he participated in a variety of projects, including meteor burst communication systems, satellite on-board processing, low probability of intercept radio, among others. In 1994 he joined INTELSAT where he initiated research and development work on the integration of terrestrial wireless and satellite systems. After working at COMSAT Labs. (1996-1997) on VSAT networks, and TranSwitch Corp.(1998-2002) on product definition and architecture, he returned to Kenya, where since 2003 he has been with Department of Electrical and Information Engineering, University of Nairobi.

Dr. Oduol was a two-time recipient of the Douglas tutorial scholarship at McGill University. He is currently chairman, Department of Electrical and Information Engineering, University of Nairobi. His research interests include performance analysis, modeling and simulation of telecommunication systems, adaptive error control, feedback communication.

Cemal Ardil is with the National Academy of Aviation, Baku, Azerbaijan