

# BER Analysis of Energy Detection Spectrum Sensing in Cognitive Radio Using GNU Radio

B. Siva Kumar Reddy, B. Lakshmi

**Abstract**—Cognitive Radio is a turning out technology that empowers viable usage of the spectrum. Energy Detector-based Sensing is the most broadly utilized spectrum sensing strategy. Besides, it's a lot of generic as receivers doesn't would like any information on the primary user's signals, channel data, of even the sort of modulation. This paper puts forth the execution of energy detection sensing for AM (Amplitude Modulated) signal at 710 KHz, FM (Frequency Modulated) signal at 103.45 MHz (local station frequency), Wi-Fi signal at 2.4 GHz and WiMAX signals at 6 GHz. The OFDM/OFDMA based WiMAX physical layer with convolutional channel coding is actualized utilizing USRP N210 (Universal Software Radio Peripheral) and GNU Radio based Software Defined Radio (SDR). Test outcomes demonstrated the BER (Bit Error Rate) augmentation with channel noise and BER execution is dissected for different  $E_b/N_0$  (the energy per bit to noise power spectral density ratio) values.

**Keywords**—BER, Cognitive Radio, GNU Radio, OFDM, SDR, WiMAX.

## I. INTRODUCTION

WITHOUT spectrum, no wireless telecommunications or wireless internet services might be conceivable. Wireless Networks/Applications would like a considerable quantity of bandwidth to allow for higher data rates. However in current situation, the accessibility of a spectrum is decreasing as a result of large traffic and huge variety of wireless applications, as very high percentage of spectrum is engaged [1]. Innovations that empower continued growth include adaptivity, smart antenna technology, and more proficient utilization of existing spectrum. Cognitive Radio (CR) [1] has the ability to sense and learn from the environment i.e. the radio parameters associated there to channel, accessibility of spectrum, user necessities and so on. In CR prototype, there are two sort of clients, the primary clients which are the authorized clients and the secondary clients (Cognitive radios) which don't have the permit of that specific range band. Spectrum sensing [1] is a much known issue. More techniques are accessible for spectrum sensing. In those, Energy detector spectrum sensing is recommended and implemented during this paper.

Cognitive systems require a Software Adaptable Network (SAN) to uphold the real system usefulness and license the

cognitive methodology to adjust the system. Also to Cognitive Radio, which depends upon a Software Defined Radio (SDR) [2] to modify parts of radio operation (e.g. frequency, time, bandwidth, spatiality, waveform, and code), a SAN takes a shot at a system that has one or more substitutable components. SDR is a radio communication framework where the greater part of equipment segments are executed in software than in hardware, by implication decreasing the system equipment cost. As of late, new advances and conventions are executed utilizing SDR. In this work, USRP N210 (Universal Software Radio Peripheral) [3] and GNU Radio [4] utilized as the hardware and software stages for the development of SDR respectively.

One of the innovations that can establish the frame-work for the following era of portable broadband systems is prevalently regarded as "WiMAX" (Worldwide Interoperability for Microwave Access) [5], is intended to convey remote broadcasting services with high Quality of Service (QoS) assures for various traffic classes, portability, and robust security. Consequently, WiMAX physical layer is actualized dependent upon OFDM/OFDMA [6] innovation and OFDMA is the enhanced technology for OFDM and permits versatility in the amount of subcarriers, adjustment and coding and so on. Error controlling code [7] may as well defend digital data against errors that experience throughout transmission over noisy channels or throughout storage in unreliable memory.

## II. SPECTRUM SENSING

Spectrum sensing is the most key part of the Cognitive Radio. The point when the primary client is the genuine authorized holder of the band begins utilizing its dispensed band; the Cognitive Radio needs to switch to different groups keeping in mind the end goal to avoid interference. The undertaking of this component is to recognize the unused frequency groups precisely and inside an exceptionally brief time span. Henceforth the design of the spectrum sensing block ought to be exceptionally straightforward but successful against noise and false triggers.

### A. Matched Filtering

The main advantage of matched filtering [1] is the brief opportunity to accomplish a certain probability of false alert or probability of miss location as related to different strategies that are talked over in this section. Besides, since Cognitive Radio includes receivers for all signal types, implementation complexity of sensing unit is impractically large. In this technique, as various receiver algorithms need to be performed for detection but power utilization is more.

B. Siva Kumar Reddy is a Research Scholar, pursuing Ph.D (Wireless Communication) in the Department of Electronics and Communication Engineering, National Institute of Technology, Warangal, Telangana, India-506004, (email:bsivakumar100@gmail.com).

Dr. B. Lakshmi is an Associate Professor, in the Department of Electronics and Communication Engineering, National Institute of Technology, Warangal, Telangana, India-506004.

### B. Waveform-Based Sensing

In the presence of a known pattern, sensing could be carried out by associating the gained signal with a known duplicate of itself. This technique is just pertinent to frameworks with known signal designs, and it is called as waveform-based sensing. Besides, it is exhibited that the execution of the sensing algorithm increases as the length of the known signal pattern increments. Let us assume that the received signal has the subsequent easy kind [1]:

$$y(n) = s(n) + w(n) \quad (1)$$

where  $s(n)$  is the signal to be noticed,  $w(n)$  is the Additive White Gaussian Noise (AWGN) sample, and  $n$  is the sample index. Note that  $s(n) = 0$ , when there is no transmission by primary user. The waveform based sensing metric can be found as

$$M = \text{Re} \left[ \sum_{n=1}^N y(n) \cdot s^*(n) \right] \quad (2)$$

where  $N$  is the length of known pattern. In the absence of the primary user, the metric value turns

$$M = \text{Re} \left[ \sum_{n=1}^N w(n) \cdot s^*(n) \right] \quad (3)$$

Similarly, in the presence of a primary user's signal, the sensing metric becomes,

$$M = \sum_{n=1}^N |s(n)|^2 \text{Re} \left[ \sum_{n=1}^N w(n) \cdot s^*(n) \right] \quad (4)$$

The decision on the presence of a primary user signal can be formed by comparing the decision metric  $M$  against a fixed threshold  $\lambda_w$ . This is equivalent to distinguishing between the following two hypotheses:

$$H_0 : y(n) = w(n) \quad (5)$$

$$H_1 : y(n) = s(n) + w(n) \quad (6)$$

The performance of the detection algorithm can be summarized with two probabilities: probability of detection  $P_D$  and probability of false alarm  $P_F$ .  $P_D$  is the probability of detecting a signal on the viewed frequency when it is truly present, thus large detection probability is needed. It can be formulated as

$$P_D = P_r(M > \lambda_w | H_1) \quad (7)$$

where  $\lambda_w$  is the threshold value.  $P_F$  is the probability that the test incorrectly decides that the considered frequency is occupied when it actually is not, and it can be defined as

$$P_F = P_r(M > \lambda_w | H_0) \quad (8)$$

PF ought to be kept as minor as could reasonably be expected. The choice edge  $\lambda_w$  could be chosen for uncovering an ideal adjust between  $P_D$  and  $P_F$ . In any case, this requires the information of noise and detected signal powers.

### C. Cyclostationarity Based Sensing

Cyclostationarity feature detection [1] is a system for discovering primary client transmissions by exploiting the cyclostationarity characteristics of the appropriated signals. Cyclostationary characteristics are brought about by the periodicity in the signal or in its facts like mean and autocorrelation. In place of Power Spectral Density (PSD), cyclic connection capacity is utilized for distinguishing signals introduce as a part of a given range. The Cyclic Spectral Density (CSD) capacity of gained signal can be defined as

$$S(f, \alpha) = \sum_{\tau=-\infty}^{\infty} R_y^\alpha(\tau) e^{-j2\pi f\tau} \quad (9)$$

$$R_y^\alpha = E[y(n+\tau)y^*(n-\tau)e^{j2\pi\alpha n}] \quad (10)$$

is the Cyclic Autocorrelation Function (CAF), and is the cyclic frequency. The CSD function outputs peak values when the cyclic frequency is equivalent to the fundamental frequencies of transmitted signal  $x(n)$ . Cyclic frequencies could be thought to be known or they might be concentrated and utilized as characteristics for distinguishing transmitted signals.

### D. Radio Identification

The objective of this technique is to recognize the presence of some known transmission technologies and attain communication through them. The two fundamental assignments are Initial Mode Identification (IMI) and Alternative Mode Monitoring (AMM) [1]. In IMI, the cognitive unit investigates for a conceivable transmission mode (system) expecting the power on. AMM is the function of saving different modes while cognitive mechanism is initiating correspondence in a certain mode.

### E. Energy Detector-Based Sensing

In this technique, prior knowledge of pilot information is not required. The execution of energy detection comprises a low pass channel to avoid out of band noise and adjacent interference, a simple to advanced converter and additionally square law device to estimate the energy. For narrow band signals and sine waves, an alternate solution is inferred i.e., periodogram is expert through square magnitude of FFT. The result is then averaged as indicated in Fig. 1. Radiometry or periodogram is prescribed for Energy detector based methodologies on account of its low computational and usage complexities. The signal is recognized by comparing the output of energy detector and a threshold which relies on upon the noise floor. Some of the challenges with energy detector

based sensing incorporate selection of the threshold for identifying primary clients, inability to separate interference from primary clients and noise, and poor execution under low Signal-to-Noise-Ratio (SNR) values. Additionally, the energy detector does not perform proficiently for distinguishing spread spectrum signals. Utilizing the same display given as a part of (1), decision metric for energy detector could be composed as [1]

$$M = \sum_{n=0}^N |y(n)|^2 \quad (11)$$

The white noise could be modeled as a zero-mean Gaussian irregular variable with change  $\sigma_w^2$  i.e.  $w(n) = n(0, \sigma_w^2)$ . For simplified investigation, gave us a chance to model the signal term as a zero-mean Gaussian variable moreover, i.e.  $s(n) = n(0, \sigma_s^2)$ . On account of these suppositions, the choice metric m takes after chi-square dissemination with  $2N$  degrees freedom  $\chi_{2N}^2$  and henceforth, it could be demonstrated as

$$M = \begin{cases} \frac{\sigma_w^2}{2} \chi_{2N}^2 H_0; \\ \frac{\sigma_w^2 + \sigma_s^2}{2} \chi_{2N}^2 H_1; \end{cases} \quad (12)$$

For energy detector, the probabilities  $P_F$  and  $P_D$  can be calculated as

$$P_F = 1 - \Gamma\left(L_f L_t, \frac{\lambda_E}{\sigma_w^2}\right) \quad (13)$$

$$P_D = 1 - \Gamma\left(L_f L_t, \frac{\lambda_E}{\sigma_w^2 + \sigma_s^2}\right) \quad (14)$$

where  $\lambda_E$  is the decision threshold, and  $\Gamma(a, x)$  is the incomplete gamma function as given in [1].

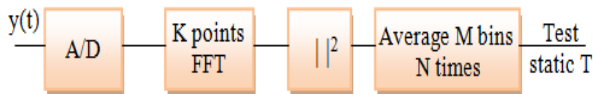

Fig. 1 Functional block diagram of periodogram

### III. CONVOLUTIONAL CODING

The example in Fig. 2 shows a set of parity equations, which given the way in which parity bits are developed from the sequence of message bits,  $X$ . In this example, the equations are as follows [7]

$$\begin{aligned} P_0[n] &= x[n] + x[n-1] + x[n-2] \\ P_1[n] &= x[n] + x[n-1] \end{aligned} \quad (15)$$

An example of parity equations for a rate  $1/3$  code [7] is

$$\begin{aligned} P_0[n] &= x[n] + x[n-1] + x[n-2] \\ P_1[n] &= x[n] + x[n-1] \\ P_2[n] &= x[n] + x[n-2] \end{aligned} \quad (16)$$

In general, one can view each parity equation as being generated by composing the message bits,  $X$ , and a generator polynomial,  $g$ . In the first example above, the generator polynomial coefficients are  $(1,1,1)$  and  $(1,1,0)$ , while in the second, they are  $(1,1,1)$ ,  $(1,1,0)$ , and  $(1,0,1)$ . We denote by  $g_i$  the  $K$ -element generator polynomial for parity bit  $P_i$ . We can then write  $P_i$  as follows:

$$P_i[n] = \left( \sum_{j=0}^{k-1} g_i[j] x[n-j] \right) \bmod 2 \quad (17)$$

The form of the above equation is a convolution of  $g$  and  $x$ —hence the term “convolutional code [7]”. The number of generator polynomials is equal to the number of generated parity bits,  $r$ , in each sliding window.

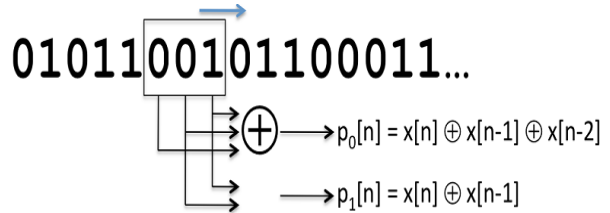

Fig. 2 Convolutional code with parity bit bits per message bit ( $r=2$ ) and constraint length ( $k=3$ )

### IV. EXPERIMENTAL RESULTS

The SDR experimental test bed (shown in Fig. 3) is equipped by using a GRC (GNU Radio Companion) installed laptop with 8 Giga Bytes of RAM and an Intel Core i5-3210M CPU clocked at 2.50 GHz. The integrated 1000 Base-T Ethernet interface was connected to the USRP N210; equipped with the CBX daughterboard which is a full-duplex, wide band transceiver that extends a frequency band from 1.2 GHz to 6 GHz with an instantaneous bandwidth of 40 MHz. The CBX can serve a wide variety of application areas, including Wi-Fi research, cellular base stations, cognitive radio research, and RADAR. In GNU radio all the signal processing blocks are written in C++ and connected by Python language. There are almost 100 signal processing blocks are available with GNU Radio installation. If a user requires some new processing blocks, those can be created by the user by using C++ and Python languages and can integrate to the GNU software. Required OFDM parameters for WiMAX specifications are tabularized in Table I.

As GRC schematic shown in Fig. 4, a captured 6 GHz signal is convolutionally coded-OFDM [6] modulated and transmitted through USRP sink over the air by using TX/RX antenna and transmitted OFDM signal (shown in Fig. 5 for 2.4 GHz) is received by the RX2 antenna with USRP source.



Fig. 3 Software Defined Radio development test bed

On the received signal, spectrum sensing is performed by using energy detection method with the flow graph is "Received signal  $\rightarrow$  Throttle  $\rightarrow$  Multiply Const  $\rightarrow$  FFT  $\rightarrow$  vector to stream  $\rightarrow$  Complex to Mag<sup>2</sup>  $\rightarrow$  Add  $\rightarrow$  Divide  $\rightarrow$  Scope sink and Number sink". Multiply const block is used to improve the amplitude level and throttle block is used to reduce the burden on CPU. The complex samples from the USRP source are changed to their magnitude form. Now this input stream is given to the FFT block in the form of a vector and the FFT samples are squared and averaged using an averaging block (Divide block). This gives the power content over a frequency band, shown in Fig. 6 and the same experiment has done for various frequencies (103.45 MHz (FM) and 710 KHz (AM)). A FM radio receiver is implemented (as shown in Fig. 7) for local station (at 103.45 MHz frequency) using USRP N210 platform, VERT 900 antenna, WBX daughterboard and GNU radio. The generated FM signal on scope sink for 103.45 MHz is shown in Fig. 8. Received FM signal is stored as .dat file and processed for the energy detection by using the same flow graph which already shown in Fig. 3. The captured FM signal and energy detector's test statistic PSD are shown in Figs. 9 & 10 with average test statistic value 0.0000027941 units. The captured AM signal at 710 KHz (shown in Fig. 11) is processed for spectrum sensing through the flow graph (shown in Fig. 4) and observed detection is shown in Fig. 12.

TABLE I  
OFDM PARAMETERS DEFINED FOR MOBILE-WiMAX SPECS

Parameters	Values
FFT size ( $N_{FFT}$ )	1024
Occupied Tones	768
Sampling rate	10.66667M
Center Frequency	2.48 GHz
Convolutional Code	1/2
Cyclic Prefix length	256
Useful symbol duration	91.43 $\mu$ s
Carrier spacing ( $1/T_u$ )	10.94 KHz
Guard time ( $T_g=(1/4)*T_u$ )	11.43 $\mu$ s
OFDM symbol duration	102.86 $\mu$ s
Mapping Schemes	BPSK, QPSK, 16QAM, 64QAM and 256QAM

$E_b/N_0$  (the energy per bit to noise power spectral density ratio) [8] is an important parameter in digital communication

or data transmission. It is a normalized signal-to-noise ratio (SNR) measure, also known as the "SNR per bit". It is especially useful when comparing the bit error rate (BER) performance of different digital modulation schemes without taking bandwidth into account.  $E_b/N_0$  is closely related to the carrier-to-noise ratio (CNR or C/N), i.e. the signal-to-noise ratio (SNR) of the received signal, after the receiver filter but before detection [8]:

$$\frac{C}{N} = \frac{E_b}{N_0} \cdot \frac{f_b}{B} \quad (18)$$

where  $f_b$  is the channel data rate (net bitrates), and  $B$  is the channel bandwidth. The equivalent expression in logarithmic form (dB):

$$CNR_{dB} = 10 \log_{10}(f_b / N_0) + 10 \log_{10}(f_b / B) \quad (19)$$

Sometimes, the noise power is denoted by  $N_0/2$  when negative frequencies and complex-valued equivalent baseband signals are considered rather than pass band signals, and in that case, there will be a 3 dB difference.

The Shannon-Hartley theorem [8] says that the limit of reliable information rate (data rate exclusive of error-correcting codes) of a channel depends on bandwidth and signal-to-noise ratio according to:

$$I < B \log_2 \left( 1 + \frac{S}{N} \right) \quad (20)$$

where  $I$  is the information rate in bits per second excluding error-correcting codes;  $B$  is the bandwidth of the channel in hertz;  $S$  is the total signal power (equivalent to the carrier power  $C$ ); and  $N$  is the total noise power in the bandwidth. Fig. 13 shows the flow graph constructed in GNU radio to present the effect of noise on the constellation and BER performance for different  $E_b/N_0$  values. The effect on constellation and BER value are shown in Figs. 14-6 for respected  $E_b/N_0$  values are 0, 10 & 31.8009 dB. The variation in BER values corresponding to  $E_b/N_0$  values are noted in Table II.

TABLE II  
BER PERFORMANCE ACCORDING TO  $E_b/N_0$

$E_b/N_0$ (in dB)	BER value (in %)
-10	11.8341
0	6.3388
10	0.0004
31.8009	0.0001

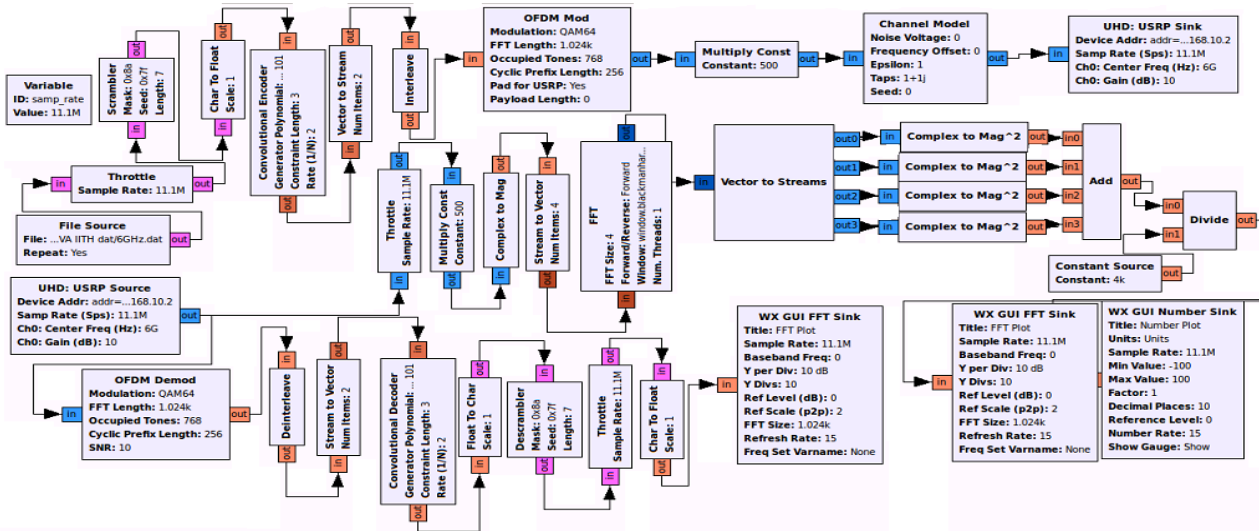

Fig. 4 GRC schematic for transmission and reception of a signal with Energy detection

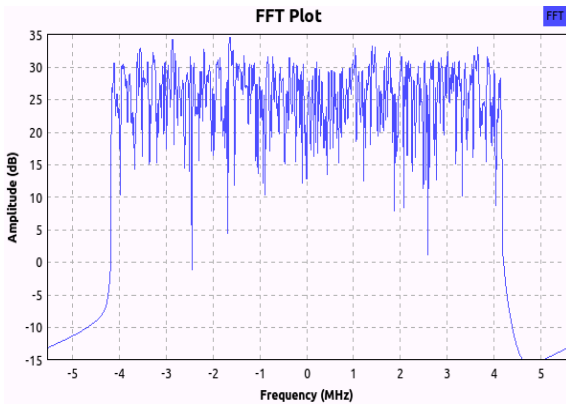

Fig. 5 Transmitted Coded-OFDM signal

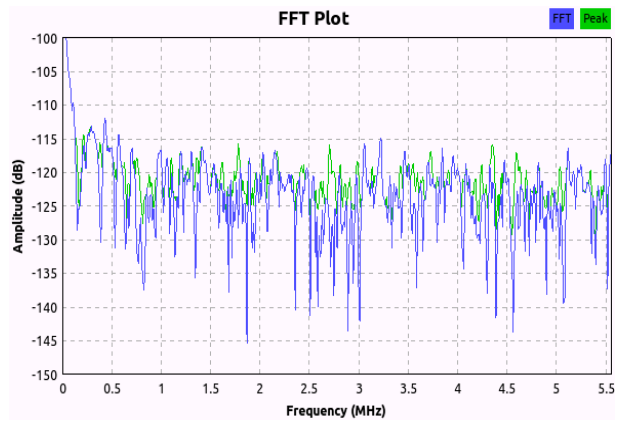

Fig. 6 Test statistic and PSD for 2.4 GHz signal

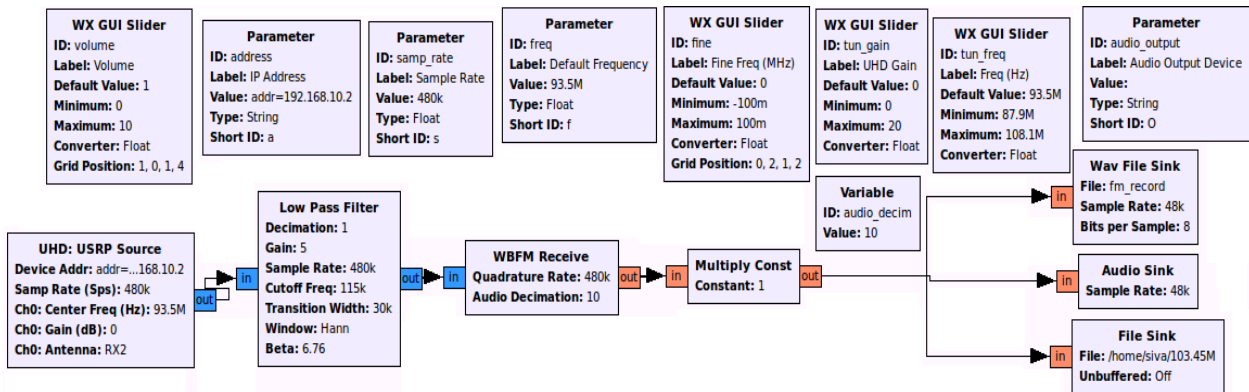

Fig. 7 A GRC schematic for FM Receiver implementation

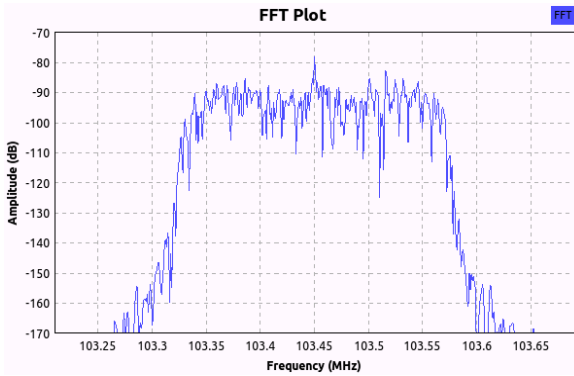

Fig. 8 Generated FM signal at 103.45 MHz

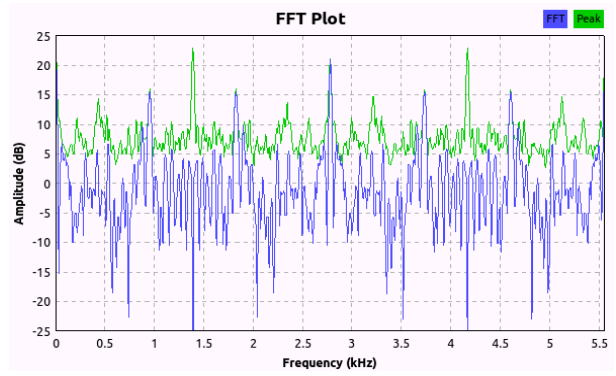

Fig. 11 Captured AM signal at 710 KHz on FFT sink



Fig. 9 Captured FM signal from .dat file

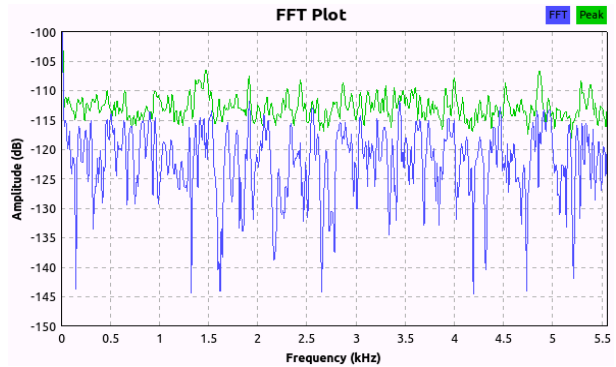

Fig. 12 Test statistic and PSD for 710 KHz AM signal



Fig. 10 Test statistic and PSD for 103.45 MHz FM signal

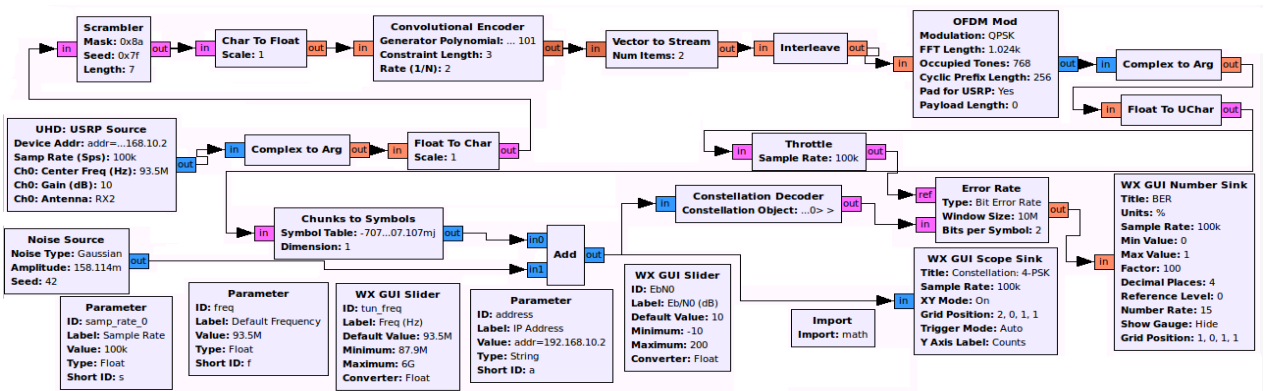
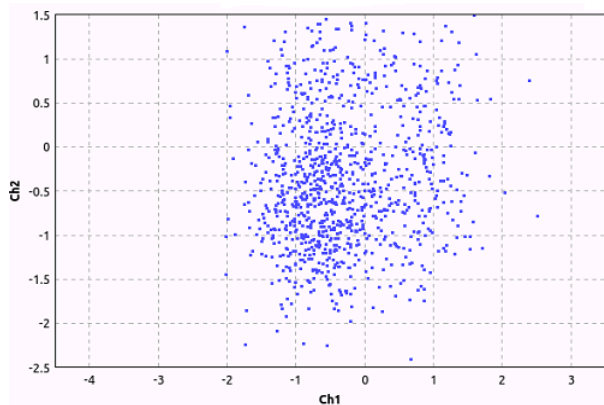
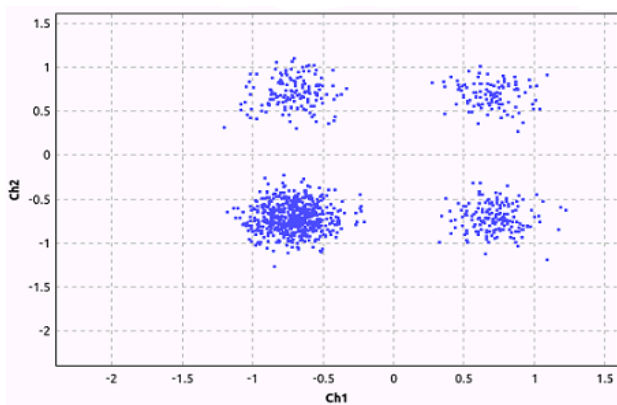
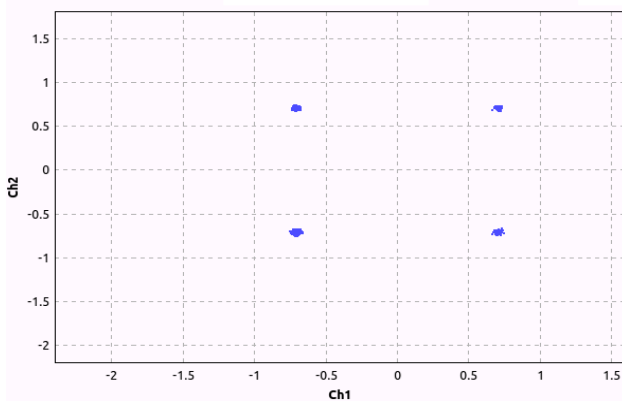

Fig. 13 A GRC schematic for BER performance analysis



Fig. 14 Effect on Constellation for  $E_b/N_0=0$  dBFig. 15 Effect on Constellation for  $E_b/N_0=10$  dBFig. 16 Effect on Constellation for  $E_b/N_0=31.8009$  dB

## V.CONCLUSION

This paper demonstrates the Software Defined Radio (SDR) development with USRP N210 and GNU Radio. GRC schematics are constructed for FM receiver, Energy detection spectrum sensing and BER performance. Number of signals at various frequencies (103.45 MHz, 710 KHz, 2.4 GHz and 6 GHz) are tested for energy detection sensing and analyzed. Results proved that BER performance becomes better when

$E_b/N_0$  value increases. Energy detection sensing is preferred due to its simplicity and no requirement of a priori knowledge of primary user signal. Convolutional code is suggested for channel coding than Block codes because in Block codes the information bits are followed by the parity bits and in convolutional codes the information bits are spread along the sequence. That means that the convolutional codes map information to code bits not block wise, but sequentially convolve the sequence of information bits according to some rule.

## REFERENCES

- [1] Arslan, Huseyin, "Cognitive radio, software defined radio, and adaptive wireless systems", *Springer London*, Limited, 2007.
- [2] Reis, Garcia and Luiz, Andre, "Introduction to the Software-defined Radio Approach", *IEEE Latin America Transactions*, vol. 10, no. 1, pp. 1156-1161, 2012.
- [3] Ettus, Matt, "USRP Users and Developers Guide", *Ettus Research LLC*, 2005
- [4] Radio, GNU, The gnu software radio, Available from World Wide Web: <https://gnuradio.org>, 2007.
- [5] Lin, Yi-Bing and Lin, Pin-Jen, "Performance Measurements of TD-LTE, WiMAX and 3G Systems", *IEEE Wireless communication,s* vol.20, 2013.
- [6] Giuliano, Romeo and Mazzenga, Franco, "Exponential effective SINR approximations for OFDM/OFDMA-based cellular system planning", *IEEE Transactions on Wireless Communications*, vol.8, no. 9, pp. 4434-4439, 2009.
- [7] B. Siva Kumar Reddy, B. Lakshmi, "Channel Coding and Clipping in OFDM for WiMAX using SDR," *International Journal on Recent trends in Engineering and Technology*, Vol. 9, pp 1-12, 2013.
- [8] Ryu, Heung-Gyoon and Kim, Do-Hoon, "Design of Wireless System with Minimum  $E_b/N_0$  and Optimization of Power Consumption", *International Journal of Energy, Information & Communications*, vol. 3, no. 2, 2012.

**B. Siva Kumar Reddy**, has received B.Tech (E.C.E) and M.Tech (VLSI Design (Very Large Scale Integrated circuits Design)) degrees from Jawaharlal Nehru Technological University, Hyderabad (JNTUH), India. Currently, he is working for a doctorate in the field of wireless communications at National Institute of Technology, Warangal, India. He is an IEEE student member, an ISTE (Indian Society for Technical Education) life time member and an IDES (Institute of Doctors, Engineers and Scientists) member.

**Dr. B. Lakshmi**, has obtained B.Tech (E.C.E) from Nagarjuana university, M.Tech (EI) from NIT, Warangal, and Ph.D (VLSI Architectures) from I.I.T, Kharagpur, India. She is working as a faculty member in National Institute of Technology, Warangal since 1990. Her areas of interests are Digital System Design, Microprocessor Systems and VLSI Architectures. She is reviewer for Elsevier journals in VLSI area.