

# Application of STATCOM-SMES Compensator for Power System Dynamic Performance Improvement

Reza Sedaghati, Mojtaba Hakimzadeh, Mohammad Hasan Raouf, Mostafa Mirzadeh

**Abstract**—Nowadays the growth of distributed generation within the bulk power system is feasible by using the optimal control of the transmission lines power flow. Static Synchronous Compensators (STATCOM) is effective for improving voltage stability but it can only exchange reactive power with the power grid. The integration of Superconducting Magnetic Energy Storage (SMES) with a STATCOM can extend the traditional STATCOM capabilities to four-quadrant bulk power system power flow control and providing exchange both the active and reactive power related to the STATCOM with the ac network. This paper shows how the SMES system can be connected to the ac system via the DC bus of a STATCOM and also analyzes how the integration of STATCOM and SMES allows the bus voltage regulation and power oscillation damping (POD) to be achieved simultaneously. The dynamic performance of the integrated STATCOM-SMES is evaluated through simulation by using PSCAD/EMTDC software and the compensation effectiveness of this integrated compensator is shown.

**Keywords**—STATCOM-SMES compensator, Power Oscillation Damping (POD), stabilizing, signal, voltage.

## I. INTRODUCTION

In recent years the progress in semiconductor technologies have resulted in the commercial accessibility to devices capable of very high power handling, leading to the concept of FACTS. Based on power electronics converter FACTS devices are capable of rapid regulation of various network quantities [1].

Among them, STATCOM could be employed to power quality improvement, power oscillations damping, transient and dynamic stability improvement [2], [3], therefore providing reactive power support and regulating power flows in the network. A STATCOM can just only absorb/inject reactive power and consequently is obligated in the degree of freedom. By the addition of energy storage, STATCOM could have the ability to exchange both real and reactive power with a transmission system independently and simultaneously, enabling STATCOM to perform several functions. Whereas the problems of uneven active power flow, the transient and the dynamic stability, the subsynchronous oscillations, and the power quality issues can be impacted more effectively by the active power control [4], this integration could be significantly.

Among the various technologies for energy storage, SMES for the power utility applications have received considerable attention due to their characteristics, such as rapid response,

high power and high efficiency [5] and provides several of benefits to the utilities: diurnal load leveling, damping of low power oscillations, spinning reserve and the transient stability enhancement.

The effects of integrating SMES with static synchronous compensator (STATCOM) on power system dynamic behavior have been investigated in [5], [6]. In [7], the experimental system integration of a battery energy storage system (BESS) into a STATCOM is discussed. In [8] the application of SSSC-SMES for frequency stabilization is examined.

In this paper, first a general model and performance principles of STATCOM-SMES compensator is proposed. Then in order to obtain bus voltage regulation and power oscillation damping simultaneously, the control scheme, and finally the simulation results for STATCOM-SMES is shown.

## II. OPERATION AND SPECIFICATION OF SMES

A SMES unit is a device that stores energy in the magnetic field generated by the DC current flowing through a superconducting coil [9], [10]. A SMES system includes a superconducting coil, the cryogenic system, and the power conversion or conditioning system (PCS) with control and protection functions [10]. Its total efficiency can be very high since it does not require energy conversion from one form to the other. Because of its benefits and unique characteristics, the SMES device is quite competitive with other energy storage technologies. Although SMES was initially considered as a diurnal energy storage device, other potential applications could be: dynamic and transient stability, frequency support, transmission capacity improvement, power quality enhancement.

## III. THE CONNECTION OF SMES WITH AC POWER SYSTEM

As can be seen from Fig. 1, a power conditioning system (PCS) connects the SMES unit to an ac power system and can be used to charge/discharge the coil [11]. A transformer provides the connection to the power system and reduces the operating voltage to acceptable levels for the PCS. Two types of power conversion systems are commonly used. One option uses a Current Source Inverter (CSI) to both interface to the ac system and charge/discharge the coil. The second option uses a Voltage Source Inverter (VSI) to interface to the ac system and dc-dc chopper to charge/discharge the coil.

Reza Sedaghati, Mojtaba Hakimzadeh, Mohammad Hasan Raouf, Mostafa Mirzadeh are with the Department of Electrical Engineering, Beyza Branch, Islamic Azad University, Beyza, Iran (e-mail: reza\_sedaghati@yahoo.com).

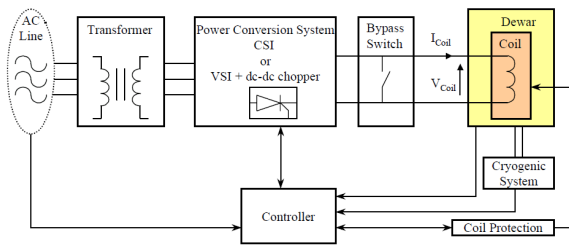

Fig. 1 Components of a typical SMES system

A. The Current Source Converter (CSC)

Due to its large inductance, the SMES coil acts like a current source [10]. Therefore, it may also be directly connected to an ac system via a CSC as illustrated in Fig. 2. With a CSC, the energy management for the SMES coil is incorporated into the ac side current output control. CSCs are simpler to control since they're not feedback coupled through the ac side impedances.

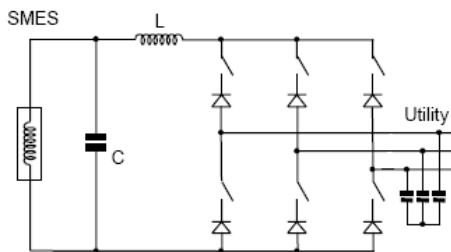

Fig. 2 The CSC topology

B. The Voltage Source Converter (VSC)

Fig. 3 shows in detail the chopper VSC topology. It used a two-quadrant chopper and a VSC connected with a DC voltage. The chopper changes the DC current from the SMES coil to DC voltage, and a VSC changes the DC voltage into a three-phase ac current. In all applications where fast power delivery and absorption are essential to improve ac system stability, the DC-DC chopper should be bi-directional [6]. Control of the real and reactive powers were accomplished by controlling firing angles of the GTOs and the DC voltage that's determined by the duty ratio of the chopper.

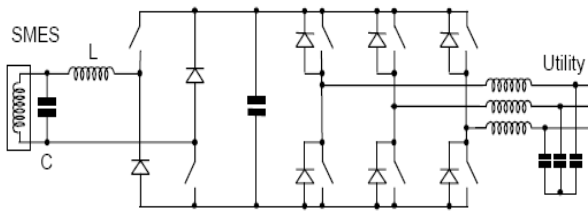

Fig. 3 The chopper-VSC topology

IV. PROPOSED MODEL FOR THE STATCOM-SMES COMPENSATOR

In fact, STATCOM is a shunt connected device which injects reactive current into the ac system. Whereas the STATCOM can just only absorb/inject reactive power,

consequently is obligated in the degree of freedom. The addition of SMES allows the STATCOM to inject and/or absorb active and reactive power simultaneously [11]. An operating model of a STATCOM-SMES compensator is shown in Fig. 4. This model consists mainly of the STATCOM controller, the SMES coil and the DC-DC chopper is adopted as interface for two devices.

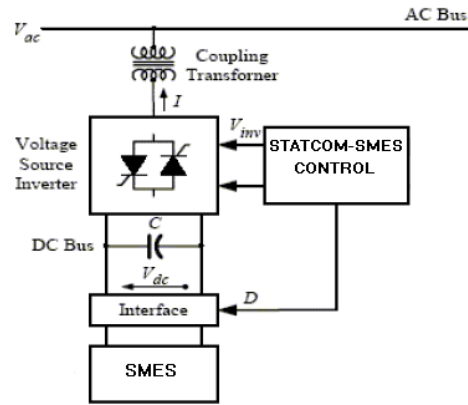

Fig. 4 General model of the integrated STATCOM-SMES compensator

V. CONTROL STRATEGY FOR THE STATCOM-SMES COMPENSATOR

The controller provides active and reactive power commands to achieve the desired system response [7]. The controller converts the commanded powers into the PWM switching commands for the STATCOM-SMES to regulate the modulation gain and angle. For the best control of transmission capacity, it is desired to have a controller to achieve the independent active and reactive power responses. To accomplish this goal, a decoupled proportional-integral (PI) controller that can produce the desired switching commands from independent active and reactive power commands is developed. The decoupled active and reactive power control can be achieved through the decoupled  $i_d$  and  $i_q$  control. At the equilibrium, there is no active power exchange between the STATCOM and SMES. A local PI controller for producing a PWM modulation index  $k$  and angle  $\alpha$  from a commanded  $P^*$  and  $Q^*$  can be developed, as shown in Fig. 5. If  $K = 0$ , this controller is decoupled;  $k$  is used to control  $P$ , and  $\alpha$  is used to control  $Q$ .

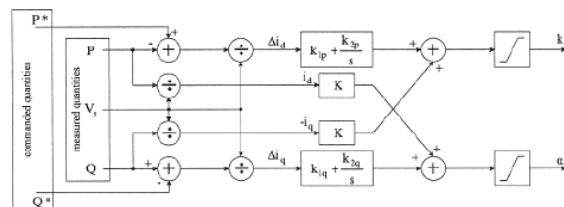

Fig. 5 Control strategy STATCOM-SMES compensator

## VI. SIMULATION RESULTS ON TEST SYSTEM

The test system is shown in Fig. 6. There is a generator with the capacity of 700 MVA at Bus A linked through transmission lines to an infinite bus, Bus C. The STATCOM is connected at Bus B. The initial conditions are 310 MW in the transmission line and Bus B regulated to 1.0pu by the STATCOM rated at  $\pm 160$  MVAR. When there is a disturbance, a lightly damped low frequency oscillation (0.5 Hz) will be existed between the generator and the infinite source. More data details of system are given in Appendix. The generator rotor swing oscillation is stimulated by applying a fixed/reliable 3phase short circuit (10 cycle duration) at the midpoint of the auxiliary transmission line (Bus C). The fault is cleared by removing the auxiliary line from service (no reclosing).

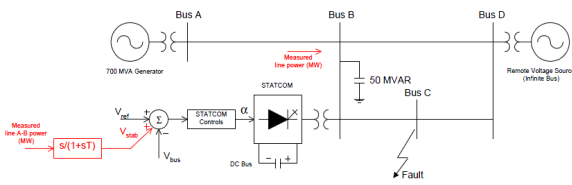

Fig. 6 Arrangement of STATCOM with Power Oscillation Damper (POD)

The magnitude of AC voltage generated by the STATCOM is directly proportional to the DC bus voltage. Therefore, the generated voltage, which controls the STATCOM VARs, is controlled by changing the DC bus voltage. Changes in DC bus voltage are accomplished by supply or absorbing real power to or from the DC bus to charge or discharge the DC capacitor. This is accomplished by leading or lagging the generated voltage angle related to the AC terminal voltage. In practice, the STATCOM has a small amount of losses (e.g. resistance in windings, switching losses etc.) and to compensate this defect the electrically generated AC voltage angle is slightly later than the AC system terminal voltage angle. The difference in angle ( $\alpha$ ) between system voltage and generated voltage allows the real power to flow and hence the losses in the STATCOM circuit will be compensated.

When the DC chopper is employed to transfer energy to/from the SMES coil, the DC bus voltage will be charged or discharged. This change will be sensed by the STATCOM controller which will automatically adjust its control angle ( $\alpha$ ) to help keeping the DC voltage at the required level. Therefore the DC chopper will be automatically tuned to provide the energy request for the SMES system. The STATCOM control automatically adjusted for the power demand of the SMES and transfers the necessary energy to/from the AC network.

Connection to the STATCOM is shown in Fig. 7 (switch A is closed). The SMES coil in these tests is rated at 4 kA with a 100 MJ capacity. The current in the coil is unidirectional and is maintained by the SMES controller between 3kA and 4kA. Prior to the disturbance, a value of 3.5 kA is flowing in the coil. The DC-DC chopper is modeled with algebraic

equations. Then, based on the requested power transfer and measured current in the coil, the desired SMES voltage is calculated. From the desired SMES voltage and the STATCOM DC voltage a value of chopper duty cycle can be computed.

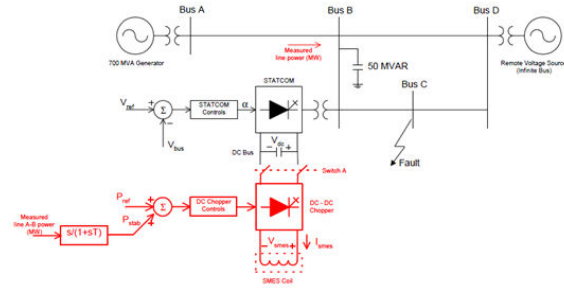

Fig. 7 Arrangement of STATCOM-SMES with Power Oscillation Damper (POD) circuit

### A. Use of STATCOM Compensator Presence

The system is as given in Fig. 6 and there is no stabilizing signal (i.e.  $V_{stab}=0$ ) feeding into the voltage control loop. The BLACK curve in Figs. 8 to 11 shows the system response. Fig. 9 shows the under damped power oscillation in the A-B line. Fig. 9 shows how the bus voltage is well regulated to the set point. Fig. 10 shows the quadrature current output (i.e. MVAR) of the STATCOM. In the next contingency period the bus voltage is well regulated, however the system oscillation mode is under-damped.

### B. Use of STATCOM Compensator Presence with POD

The system diagram is given in Fig. 6 and the stabilizing signal that adds into the voltage control loop is defined by the relationship in (1), where  $P_{meas}$  could be the measured real power flowing in the transmission line between busses A and B, 's' represents the derivative function. The signal is bound between  $\pm 0.05$  pu.

$$V_{stab} = \frac{3.75e-4}{1+0.2s} \cdot s \cdot P_{meas} \quad (1)$$

The BLUE traces on Fig. 8 through 11 show the system response. As it can be seen in Fig. 8, the power oscillation is much better damped than the STATCOM when is used only. However the bus voltage is now modulated in Fig. 9. The stabilizing signal is shown in Fig. 12.

### C. Use of STATCOM-SMES Compensator Presence with POD

The system diagram is given in Fig. 7. The stabilizing signal is defined in (2) and is bound between  $\pm 20$  MW. The gain has been selected to achieve the same damping as for the STATCOM+POD case.

$$P_{stab} = \frac{0.3}{1+0.2s} \cdot s \cdot P_{meas} \quad (2)$$

The RED traces on Figs. 8-11 show the system response. Figs. 8 and 9 respectively show that the power oscillation is well damped and the bus voltage is well regulated. In Fig. 11 the phase component of STATCOM current is non-zero and this corresponds to the real power transfer to/from the SMES system. Fig. 13 shows the stabilizer signal, the level of power (20 MW) necessary to damp the oscillation is quite small in accordance with the rating of the STATCOM.

The SMES voltage and current waveforms are shown in Fig. 14. The SMES current remains fairly constant around 3.5 kA; however, the modulated power is accomplished by changing the SMES voltage. The STATCOM-SMES with POD combination could be effective to damping of low frequency oscillations and also providing voltage regulation at the same time.

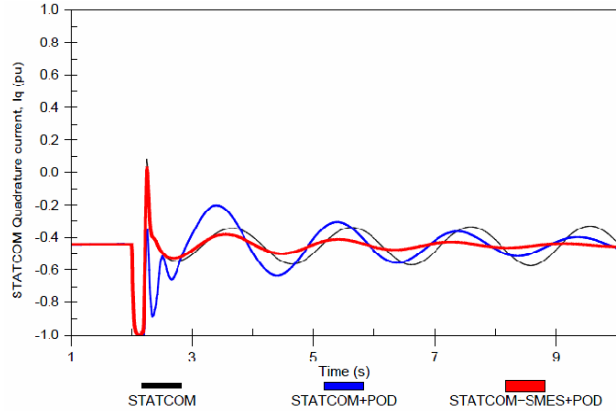

Fig. 10 STATCOM quadrature current output

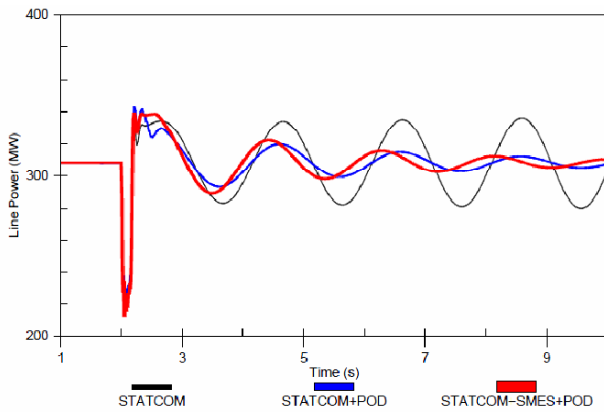

Fig. 8 Line power oscillation

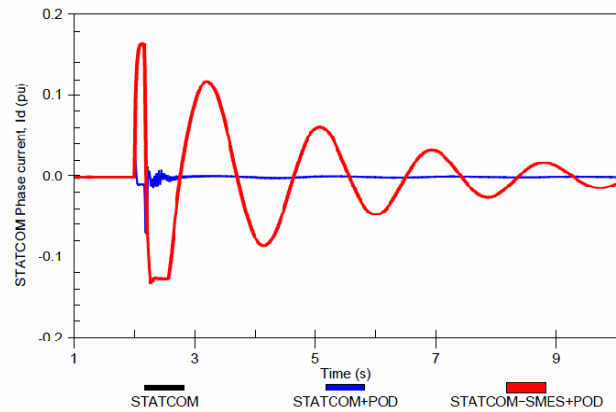

Fig. 11 STATCOM phase current output

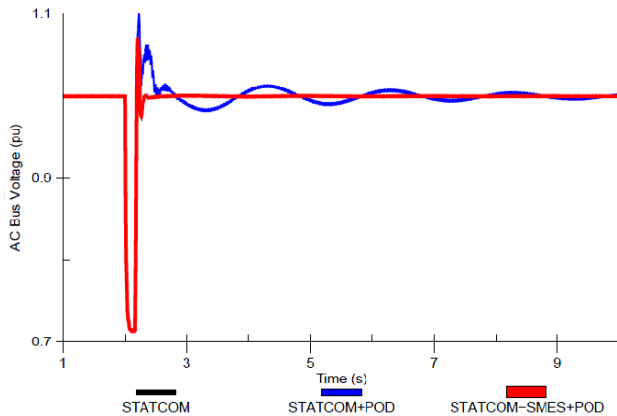

Fig. 9 AC bus voltage

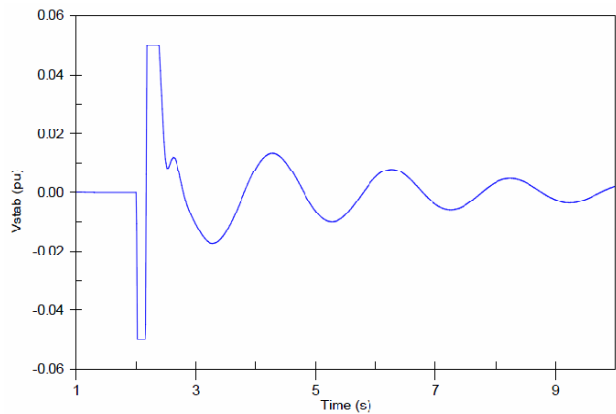

Fig. 12 Stabilizer signal for voltage control loop of STATCOM

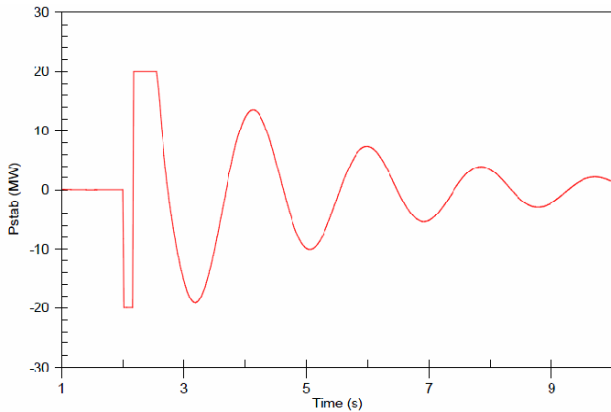

Fig. 13 Stabilizer signal for power reference of SMES controller

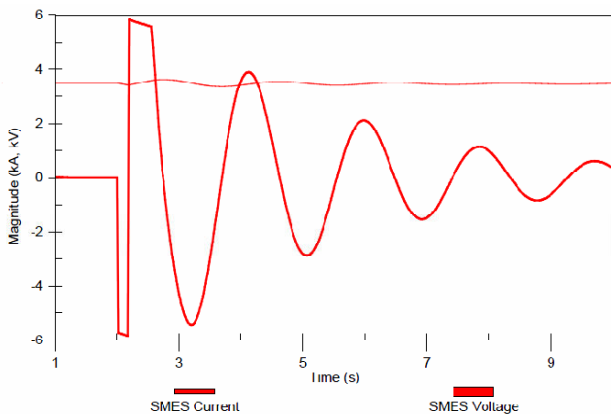

Fig. 14 SMES coil waveform

## VII. CONCLUSION

In this paper an advantage of adding a SMES system to the DC bus of a STATCOM has been considered. The power oscillation damping performance of a STATCOM has been compared with a STATCOM-SMES combination. An active power signal conditioned to provide an auxiliary control signal for the voltage source (in the case of STATCOM) or SMES power source (in the case of STATCOM-SMES combination) was compared. The ability of both schemes to damp machine rotor swing oscillations at 0.5 Hz has been demonstrated. The results illustrate that STATCOM (i.e. no POD) will regulate voltage in the next contingency period when is used only, but it cannot automatically add much damping to power oscillations. The STATCOM with POD signal placed on its voltage reference may damp swing oscillations following a disturbance; however, this is achieved by using of voltage regulation. The combination of STATCOM-SMES with POD modulating the SMES output will allow the system to both regulate voltage and provide oscillation damping. The amount of real SMES power, necessary to damp system oscillations is quite small (20 MW) related to the STATCOM rating (160 MVAR). The controls of the STATCOM were not specially modified to accommodate the operation of the SMES coil.

## APPENDIX

### System Data

- Base Frequency = 60 Hz
- Bus A Generator: Rating=700 MVA, H=8.9sec,  $X_d' = 0.3$  pu
- SMES: maximum current 4KA, 100 MJ energy capacity
- STATCOM rating:  $\pm 160$  MVA, transformer leakage 15%
- Line A to B:  $X = 22$  Ohms
- Line B to D:  $X = 14$  Ohms
- Line B to C & C to D:  $X = 22$  Ohms
- All lines have  $X/R = 20$ .

## REFERENCES

- [1] N.G. Hingorani and L. Gyugyi, "Understanding FACTS Concepts and Technology of Flexible AC Transmission Systems", IEEE Press, 2000.
- [2] L. Gyugyi, "Application Characteristics of Converter Based FACTS Devices," Power System Technology, 2000. Proceedings. PowerCon 2000. International Conference, Vol.1, Page(s):391 - 396, 4-7 Dec. 2000.
- [3] Q. Yu, P. Li, W. Liu, X. Xie, "Overview of STATCOM Technologies", IEEE International Conference on Electric Utility Deregulation, Restructuring and Power Technologies, April, 2004.
- [4] L. Zhang, C. Shen, Z. Yang, M. Crow, A. Arsoy, Y. Liu, S. Atcitty, "A Comparison of the Dynamic Performance of FACTS with Energy Storage to a Unified Power Flow Controller," IEEE Transactions on Power Deliver, vol.6, pp.611-616, 2001.
- [5] A.B. Arsoy, Y. Liu, P.F. Ribeiro, "Static synchronous compensators and superconducting magnetic energy storage systems in controlling power system dynamics", IEEE Industry Applications Magazine, Mar/Apr 2003.
- [6] A. Griffo, D. Lauria, "Superconducting Magnetic Energy Storage Control Strategy for Power System Stability Improvement", Bepress, volume 4, Issue 1, 2005.
- [7] Z. Yang, C. Shen, L. Zhang, M. L. Crow, and S. Atcitty, "Integration of a STATCOM and battery energy storage," IEEE Trans. Power Syst., vol. 16, no. 2, pp. 254-260, May 2001.
- [8] I. Ngamroo, "Robust Frequency Stabilization by Coordinated Superconducting Magnetic Energy Storage with Static Synchronous Series Compensator", Bepress, volume 3, Issue 1, Article 1031, 2005.
- [9] H. Zhang, Y. Kang, P. Zhu, X. Kong, P. Liu, and J. Chen, "Theoretical analysis and experimental results on SMES in dynamic simulation test of power system," in Proc. of IEEE Conf. Elect. Machines and Drives, pp. 736-741, 2001.
- [10] P. Alto, "Program on Technology Innovation: Modeling of SMES and Its Integration to the Power Grid," EPRI Project Manager, Oct 2005.
- [11] P. Ribeiro, B. Johnson, M. L. Crow, A. Arsoy, and Y. Liu, "Energy storage systems for advanced power applications," Proc. IEEE, vol. 89, no. 12, pp. 1744-1756, Dec. 2001.