

Analysis of Vortical Structures Generated by the Swirler of Combustion Chamber

Vladislav A. Nazukin, Valery G. Avgustinovich, Vakhtang V. Tsatiashvili

Abstract—The most important part of modern lean low NOx combustors is a pre-mixer where swirlers are often used for intensification of mixing processes and further formation of required flow pattern in combustor liner. Swirling flow leads to formation of complex eddy structures causing flow perturbations. It is able to cause combustion instability. Therefore, at design phase, it is necessary to pay great attention to aerodynamics of premixers. Analysis based on unsteady CFD modeling of swirling flow in production combustor swirler showed presence of large number of different eddy structures that can be conditionally divided into three types relative to its location of origin and a propagation path. Further, features of each eddy type were subsequently defined. Comparison of calculated and experimental pressure fluctuations spectrums verified correctness of computations.

Keywords—DES simulation, swirler, vortical structures.

I. INTRODUCTION

FOR the last decades, one of critical problems for developers and manufacturers of power generation or mechanical drive gas turbines is reduction of pollutants emission. At present, the main trend is development of lean combustors. Lower flame temperature contributes to reduction of NOx formation rate, though at the same time to increased emission of carbon monoxide [1]. Use of lean combustion technology is also accompanied by such requirements as sufficient lean blow-out margin, absence of combustion fluctuations, and adequate thermal condition of liner components at insufficient cooling air supply. Operation process in modern combustors where the biggest portion of air is supplied to primary zone is mainly defined by pre-mixer design which is responsible for required velocity and concentration fields at combustor liner inlet. Most premixers have swirlers as swirling flows enable intensification of mixing and provide conditions for generation of recirculation zone required for aerodynamic stabilization of flame front [2].

Swirling flows have certain features, for example, flow cannot be axially symmetric at high swirl numbers as the flow core having tangential velocity distributed as rigid body becomes unstable and starts precessing around the axis of symmetry [2]. Depending on certain conditions, precessing

vortex core (PVC) may consist of one or two strong vortical structures as observed by Kris Midgley et al. [3]. PVC may emerge and be suppressed at certain conditions. Analysis by Mores J Wankhede et al. showed [4] that combustion induced vortex breakdown leads to flashback into mixer resulting significant emission increase as well as can cause mixer failure. Precessing vortical structures are also harmful as they cause periodic velocity fluctuations at pre-mixer exit. If these fluctuation frequencies coincide with one of liner acoustic modes low-frequency combustion instabilities may occur. Its mechanism is schematically shown in Fig. 1.

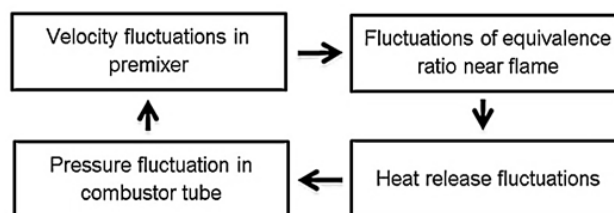

Fig. 1 Mechanism of combustion instabilities

Beside air/fuel ratio fluctuations, heat release fluctuations may be associated with flame leading edge dynamics of aerodynamically stabilized flames studied in [5]. Both flow fluctuations at pre-mixer exit and external perturbations influence the position of this stabilization point. Therefore, in designing of premixers with swirlers, special emphasis should be made on their aerodynamics and proper prediction of swirling flows. At present, the most effective method that allows swirling flows analysis is computational fluid dynamics (CFD).

The previous work [6] was directed to comparison of traditional approach to modeling of fluid dynamics that is based on Reynolds averaged Navier-Stokes (RANS) system of equations with two-parameter turbulence models and advanced approach that implies Detached Eddy Simulation (DES). It has shown that only DES approach can be used to describe generation and propagation of complex vortical structures, such as PVC.

The goal of this work was use unsteady CFD modeling with DES turbulence model for study of vortical structures generated by the real combustor swirler. It was required to reveal principal emergence locations of vortex structures and estimate their effect on the flow in order to understand whether negative or positive contribution they can make to operation process in lean combustor.

Vladislav A. Nazukin is a postgraduate student with the National Research Polytechnic University of Perm. 614990, 29 Komsomolsky prospect, Perm, Russia (e-mail: v.a.naz@narod.ru).

Valery G. Avgustinovich is a professor of aviation engines with the Department at National Research Polytechnic University of Perm. 614990, 29 Komsomolsky prospect, Perm, Russia (e-mail: avgust@avid.ru).

Vakhtang V. Tsatiashvili is a vice head of combustion chambers with the department at Aviadvigatel Company. 614990, 93 Komsomolsky prospect, Perm, Russia (e-mail: vtsati@mail.ru).

II. EXPERIMENTAL RESULTS

Experimental study of swirler was performed in acoustic laboratory of Perm National Research Polytechnic University.

Test object was a swirler of industrial gas turbine diffusion combustor.

The general layout, swirler and microphones position is shown in Fig. 2.

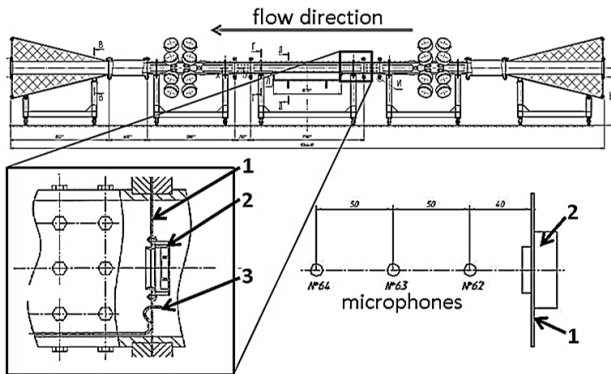

Fig. 2 Rig General view (top), mounted swirler (left) and microphones arrangement (right). Key: 1-plate; 2 – swirler; 3 – instrumentation

The swirler was mounted on a plate which baffled the rig duct. In 100x1500 mm duct upper part 9 microphones were located as shown on above layout (3 locations). Signals from the rest of them (6 locations) were not used in this test. Total and static pressure drop across the plate was monitored through instrumentation.

During test the noise generated by the swirler was measured at pressure drop across the plate equal 3, 4 and 5 kPa. 3 kPa noise was got into focus of further study.

Signal from mic. 62, 63, 64 located downstream of the swirler (see Fig. 2) was processed using FFT. Obtained spectra are represented in Fig. 3.

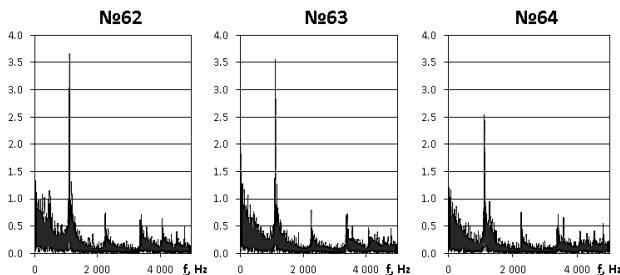

Fig. 3 Spectra of microphones signal

The main peak is present through all these spectra at 1140 Hz. It also appears at frequency two and three times higher of lower amplitudes. It was supposed that 1140 Hz fluctuations might be caused by flow perturbations generated from PVC. In this case its precession frequency can be defined, thus, obtained experimental data can be used for verification of analysis of flow in the studied swirler. For comparison, signals were filtered because ANSYS CFX uses numerical schemes of

low order accuracy due to which high frequency fluctuations dissipate quickly. Also, because of limited computation resources it does not seem possible to accumulate enough statistics required for acquisition of low-frequency fluctuation data.

III. COMPUTATIONAL MODEL

Geometry model of computational domain was created based on known dimensions of swirler, plate and rig duct. Swirler shown in Fig. 4 consists of 18 blades and short nozzle. Swirler front wall has a hole for injector but it was blocked during test, therefore, the wall in the mode was solid. The swirler feature is circular flow baffle.

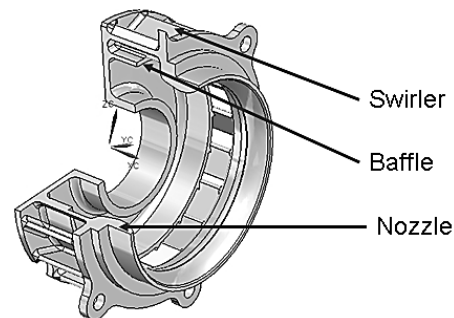

Fig. 4 Studied swirler

To avoid boundary conditions effect on swirler flow rig duct length was 500 mm before the plate and 750 mm after the plate.

The computational grid was generated using ICEM CFD software. It consists of 26248424 elements. The typical sizes of elements are shown in Fig. 5.

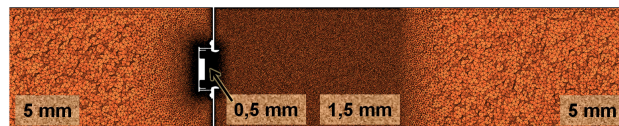

Fig. 5 Computational grid

ANSYS CFX was used as a computational tool. 15°C air was used as a isothermal fluid. Air mass flow equal to 0.037936 kg/sec was set up as the inlet boundary condition and static pressure equal to 1 atm was set up at the outlet.

Initially, steady-state computation was made using SST turbulence model and auto timescale to obtain initial condition for unsteady computation. Basic computation containing 20000 timesteps corresponded to 0.2 sec. of physical time. The computation time was about $2.8 \cdot 10^4$ CPU Hrs. In locations where microphones were mounted, in 2 mm distance from the duct wall static pressure indications were recording.

IV. RESULTS OF COMPUTATIONS

Instantaneous velocity fields are shown in Fig. 6. It reveals that vortex breakdown and central recirculation zone (CRZ) penetrate into the swirler as well as outer recirculation zone

(ORZ) appears due to high flow swirl number. In spite of relatively simple design numerous vortical structures occur. They cause significant velocity non-uniformity at swirler exit. The rotation of axial velocity field around the axis of swirler suggests existence of PVC. Velocity.Swirling.Strength parameter (the imaginary part of complex eigenvalues of velocity gradient tensor in CFX [7]) was used to represent vortical structures in the swirler. To understand vortex intensity, isosurface shown in Fig. 7 (upper left) is colored consistent with static pressure. Also, this figure represents static pressure profile at swirler exit plane for different time points (upper right and lower).

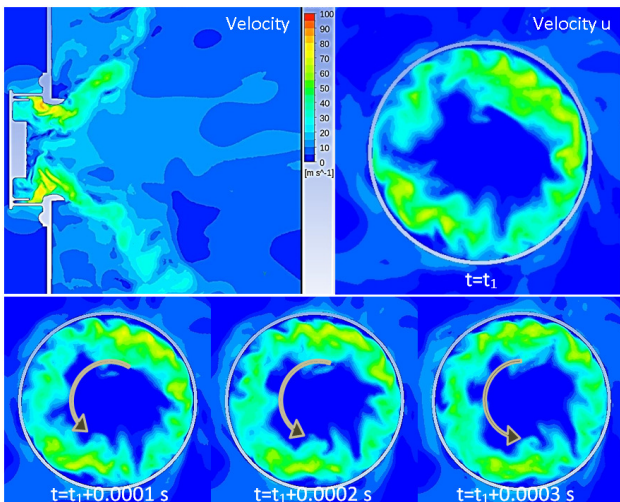

Fig. 6 Instantaneous velocity profiles: absolute (upper left) and axial (upper right and lower)

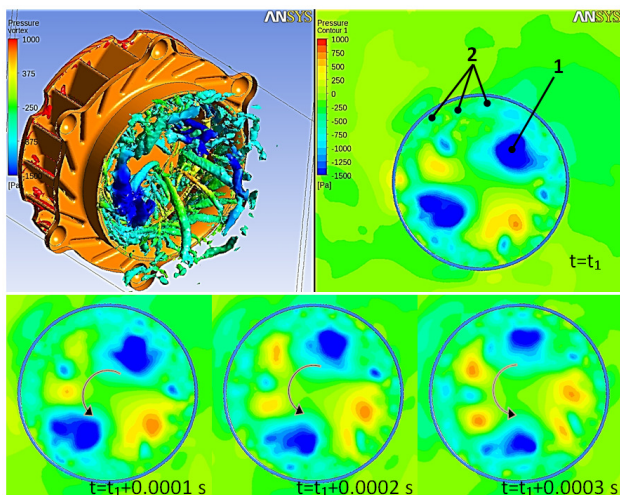

Fig. 7 Vortex structures (upper left) and instantaneous pressure profiles (upper right and lower)

All vortical structures may conditionally be divided into 3 groups depending on place of origin and further propagation path: 1 - PVC, 2 - vortices originated between swirler blades, 3 - toroidal vortices under flow baffle (it is not depicted in the

figures above). Each type of vortex requires further and detailed study and estimation of possible effects in case such vortices appear in pre-mixer of lean combustor.

PVC originates near the swirler front wall. It contains two strong and few significantly weaker vortices. Their origination is associated with interaction of swirl flow going out of vane passages with central recirculation zone (strong and weak eddies) and toroidal vortex under flow baffle (some weak eddies). Generally, strong vortices are located opposite each other. But their size and relative angle location are constantly changing with time. During rotation merging/breakdown of eddies happens as well as some of them fade away and new ones are generated. Coming out of the swirler, precessing vortices propagate along the central recirculation zone border. In lean combustor, the drawback of these eddies is significant velocity fluctuation in flame front stabilization area which are clearly seen in Fig. 8 and they may cause periodical heat release fluctuations. Thus, when designing premixers, it is necessary to exclude conditions for generation of strong precessing vortex structures or decrease their intensity.

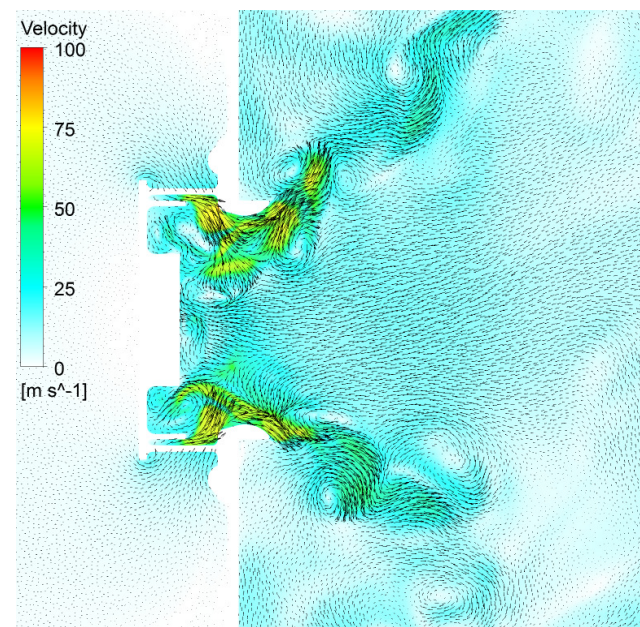

Fig. 8 Strong vortical structures, generated by the swirler

Weak eddies flown out of vane passages originate in the area where swirler blades are mating with flow baffle. They are propagating near the nozzle inner wall and further along ORZ boundary. Their effect on the velocity field is eligible in comparison with the effect of PVC. These eddy structures are able to intensify fuel and air mixing though at the same time fuel can concentrate in low pressure regions inside vortices.

Inside the swirler under flow baffle toroidal vortices originate and 1-3 vortex structures may exist there. Their interaction with swirl flow results in generation of new eddies propagating towards the swirler exit. Due to the fact that shape and size of toroidal eddies changes with time, they periodically block swirler vane passages reducing the flow

through passages. Fig. 9 shows variation of mass flow through the 2 passages with relative angle 60° during 0.005 sec.

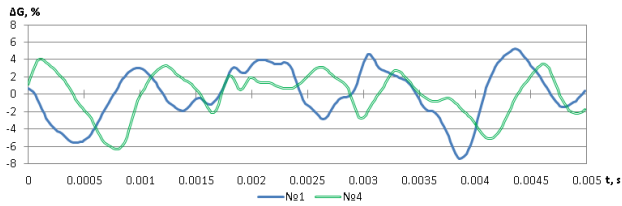

Fig. 9 Mass flow fluctuations through 2 passages

The figure indicates that both passages have periodical mass flow fluctuation up to 8% amplitude. Besides, Passage 4 fluctuations are phase-shifted relative to Passage 1 fluctuations. It indicates periodical variation of toroidal vortex shape inside the swirler. In case such flow pattern occurs in premixer design discussed mass flow fluctuations can cause equivalence ratio periodic fluctuations at liner inlet which may result in combustion instabilities shown in Fig. 1. To prevent this situation, toroidal vortical structures localised inside premixer should be avoided.

To verify results of the computations, computed pressure fluctuations were compared with experimental data in the points corresponding to microphones locations (Fig. 10). Preliminary the signals were twice processed using moving average filter.

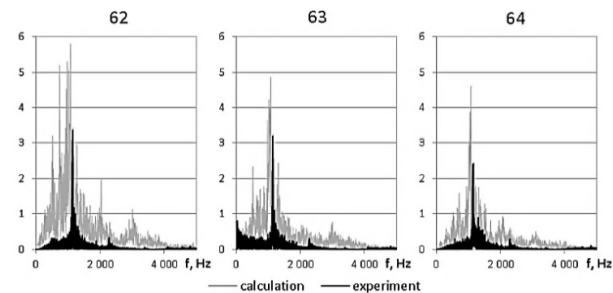

Fig. 10 Spectrums of filtered signals

Peaks in computational spectra are not so much expressed compared to experiment. It is explained both by lower spectrum resolution in terms of frequency (5 Hz for computation and 0.54 Hz for experiment) and unstable nature of eddy structures during computation. Frequency that corresponds to maximum peak for all 3 points is 1050 Hz that is 8% lower than the value obtained from experiment. Analysis of static pressure profile variation in swirler exit plane showed that strong eddies pass half of way in rotation during 0.0005 sec. Therefore, pressure fluctuations at 1050 Hz are caused by PVC rotation. According to Fig. 9 mass flow fluctuations also have frequency close to 1000 Hz. Therefore PVC rotations and toroidal vortex fluctuations are interrelated.

Lower fluctuation frequency values in computations might be caused by inaccuracy of boundary conditions definition. It was also supposed that this difference might be caused by the Doppler Effect. In analysis static pressure fluctuations were

monitored. Thus their frequency is equal to eddy precession frequency. During experiment, microphones recorded sound waves generated by PVC in dynamic flow. Frequency of waves sensed by stationary transducer is defined from (1):

$$f = f_0 \frac{1}{1 - \frac{v_{src}}{c}} \quad (1)$$

where f_0 is frequency of waves if source and transducer are stationary, v_{src} – source velocity relative to transducer, c – local speed of sound. As mean flow velocity at premixer exit was ~ 30 -40 m/sec. frequency PVC rotation should be ~ 9 -11% lower than frequency of sound waves sensed by microphones. In this case the difference between the computation and the experiment is just 1-3%. This fact confirms correctness of DES simulation.

Also, it was noticed that steady-state analysis results didn't have even qualitative agreement with time-averaged unsteady results. Fig. 11 represents comparison of velocity profiles at rig axial section. It is probably caused by numerous eddies appeared for this design.

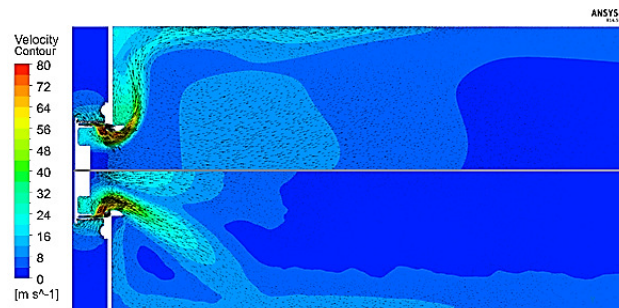

Fig. 11 Comparison of steady (top) and time-averaged (bottom) velocity profiles

The main difference is associated prediction of recirculation zones shapes and sizes. It means that a comparison between different types of computations is necessary for each configuration in order to make conclusion on further RANS application.

V. CONCLUSION

In spite of simple design of swirler various eddy structures were observed which were classified by three groups. Analysis of their effect on flow structure showed that during designing of lean combustor premixers it's advised to avoid strong precessing eddy structures as well as eddies localized inside mixing passage as they are able to cause combustion instabilities. Vortices originated in vane passages or vane wakes can affect fuel/air mixing inside premixer but they don't have significant influence on flowfield. Acoustic test of studied swirler make it possible to find out precession frequency of vortex core. During computation PVC was observed which frequency was only 8% lower than in experiment but this difference can be caused by Doppler

Effect. Finally, it was determined that steady-state computations don't always make it possible to obtain correct flow structure for high swirling flows.

ACKNOWLEDGMENT

This work has been accomplished by financial support of Perm Regional Ministry of Education.

REFERENCES

- [1] Lefebvre A. H. "Gas Turbine Combustion", 3rd edition, CRC Press, New York, 2010.
- [2] Gupta A. K., Lilley D. G., Syred N. "Swirling flows", Abacus Press, Tunbridge Wells, UK, 1984.
- [3] Midgley K., Spencer A., McGuirk J. J. "Unsteady flow structures in radial swirler fed fuel injectors", ASME GT2004-53608, ASME Turbo Expo 2004, Vienna, Austria
- [4] Wankhede M. J., Bresslof N. W., Keane A. J., Caracciolo L., Zedda M. "An analysis of unstable flow dynamics and flashback mechanism inside a swirl-stabilised lean burn combustor", ASME GT2010-22253, ASME Turbo Expo 2010, Glasgow, UK.
- [5] Malanosky M., Aguilar M., O'Connor J., Shin D., Noble B., Lieuwen T. "Flame leading edge and flow dynamics in a swirling, lifted flame", ASME GT2012-68256, ASME Turbo Expo 2012, Copenhagen, Denmark
- [6] Nazukin V. Avgustinovich V. et al. "Test case of 3D unsteady flows modeling using commercial and in-house codes", Bulletin of Samara State Aerospace University, vol. 4(42), pp. 197-206, 2013.
- [7] ANSYS, Inc., "ANSYS CFX-Solver theory guide", ANSYS, Inc., Canonsburg, US, 2010.