

Analysis of Driver Point of Regard Determinations with Eye-Gesture Templates using Receiver Operating Characteristic

Siti Nor Hafizah binti Mohd Zaid, Mohamed Abdel-Maguid, and Abdel-Hamid Soliman

Abstract—An Advance Driver Assistance System (ADAS) is a computer system on board a vehicle which is used to reduce the risk of vehicular accidents by monitoring factors relating to the driver, vehicle and environment and taking some action when a risk is identified. Much work has been done on assessing vehicle and environmental state but there is still comparatively little published work that tackles the problem of driver state. Visual attention is one such driver state. In fact, some researchers claim that lack of attention is the main cause of accidents as factors such as fatigue, alcohol or drug use, distraction and speeding all impair the driver's capacity to pay attention to the vehicle and road conditions [1]. This seems to imply that the main cause of accidents is inappropriate driver behaviour in cases where the driver is not giving full attention while driving. The work presented in this paper proposes an ADAS system which uses an image based template matching algorithm to detect if a driver is failing to observe particular windscreen cells. This is achieved by dividing the windscreen into 24 uniform cells (4 rows of 6 columns) and matching video images of the driver's left eye with eye-gesture templates drawn from images of the driver looking at the centre of each windscreen cell. The main contribution of this paper is to assess the accuracy of this approach using Receiver Operating Characteristic analysis. The results of our evaluation give a sensitivity value of 84.3% and a specificity value of 85.0% for the eye-gesture template approach indicating that it may be useful for driver point of regard determinations.

Keywords—Advanced Driver Assistance Systems, Eye-Tracking, Hazard Detection.

I. INTRODUCTION

ROAD traffic accidents are a major cause of death and injury worldwide. According to the World Health Organisation [2], one million people are killed and fifty million people are seriously injured each year due to road accidents. The figures are particularly worrying for young men as road accidents represent the main cause of death for males under the age of 25 within the Organization for Economic Cooperation and Development (OECD) countries [3].

According to a UK Department of Transport, there were 453 pedestrians killed and 5,454 seriously injured on Great Britain's roads in 2011. In the same year, 107 cyclists were

killed and 3,085 were seriously injured[4].

These statistics have motivated research in the field of Advance Driver Assistance Systems (ADAS) that aims to improve driver performance and thus help to reduce road accidents. ADAS systems are on-board computer systems linked to various sensors to detect environmental, vehicle and driver conditions and to respond to them in such a way as to help the driver to avoid a vehicle collision. ADAS systems aim to assist the driver in the driving process in the hope that they will save lives and injury by aiding drivers to make prompt, safe decisions about executing driving manoeuvres.

The work presented in this paper is an extension of our earlier work on the Non-intrusive Intelligent Driver Assistance and Safety System (Ni-DASS) [5],[6],[7]. In Ni-DASS, a template matching algorithm is used to match eye-gesture templates of the driver's left eye with video frames of the driver's eyes during normal driving in order to determine the driver's point of regard on the windscreen. The aim of this process is to determine whether the driver has failed to see a potential hazard and to issue a warning in such cases. Because of the 'look but not see' phenomenon, it is very difficult to determine if the driver has actually observed a hazard. However, it is often possible to determine if the driver has failed to observe a hazard simply because he/she has been looking at something else. The main contribution of this paper is to assess the utility of the eye-gesture template approach for driver point of regard determinations using Receiver Operating Characteristic (ROC) analysis. ROC analysis is commonly used to determine the effectiveness of a test based upon the sensitivity (true positive) and specificity (true negative) rates. In the context of this paper, the test is a template matching algorithm using eye-gesture templates to determine the driver's point of regard on the windscreen.

The rest of this paper is organised as follows: Section 2 gives a review of related work; Section 3 presents ROC analysis for the eye-gesture template approach; Section 4 investigates the accuracy of eye-gesture templates in terms of the size of the windscreen cells; Section 5 presents conclusions about the eye-gesture template approach.

II. PREVIOUS WORK

There has been increasing research interest in the field of driver distraction detection for ADAS [8], [9]. These systems hope to use remote video camera based eye-tracking systems to detect situations when the driver is not paying sufficient attention to the vehicle and environment. These approaches have two core components: an eye-tracking system able to

Siti Nor Hafizah binti Mohd Zaid is with the Computing, Engineering and Science Faculty, Staffordshire University, Beaconsfield, ST16 3QJ, UK (phone: +44(0)7545322452; e-mail: s.n.mohdzaid@staffs.ac.uk).

Mohamed Abdel-Maguid is with the Computing, Engineering and Science Faculty, Staffordshire University, Beaconsfield, Stafford ST180AB UK. (e-mail: m.mabd-el-maguid@staffs.ac.uk).

Abdel-Hamid Soliman is with the Computing, Engineering and Science Faculty, Staffordshire University, Beaconsfield, ST 180AB, UK (e-mail: a.soliman@staffs.ac.uk).

track the driver's point of regard within the vehicle and environment and a suitable metric that can be used to determine if the driver is distracted with the aim of alerting the driver if he/she is not being attentive.

Some researchers have developed ADAS systems able to determine if the driver has observed objects within the environment.[10],[11] have employed driver eye-gaze detection to monitor whether the driver is looking to the road scene. The system attempts to identify parameters relating to the dynamic road environment and features related to the driver's observations so as to make inferences about the driver's behaviour. They demonstrate this by detecting road signs and use gaze estimation to determine if the driver has observed the sign. Gaze estimation is accomplished with a commercial eye-tracking system called faceLAB from Seeing Machines. The driver's eye-gaze is correlated with real-time sign recognition. The behaviour of the driver several seconds before and after sign detection is used to decide whether an appropriate alert should be given.

There is some work on driver hazard detection. [5] employed eye-gesture templates to determine whether the driver is making mirror observations while executing manoeuvres. The work on eye-gesture templates was then extended to include driver's point of regard on the windscreen with the aim of determining whether the driver has failed to observe hazards on the road [6]. Here, the authors hope to alert the driver in situations where he/she has failed to observe a hazard. The utility of eye gesture analysis has been further extended to include head movement [7]. In order to incorporate head movement, different sets of eye-gesture templates are created for different head-poses. The appropriate template set is then selected based upon detecting the driver's head pose using the approach of [12]. This is an important addition to the algorithm as drivers routinely change their head-pose while making observations.

There are a few researchers [13], [14] that have used eye-gaze and head movements to predict driver intent to perform lane changes. [15] presents a comparative study of the use of changes in eye gaze and head movements in predicting driver intent to perform lane changes. To monitor eye gaze, they position a monocular camera trained at the drivers face in the middle of the dashboard. Due to the difficulty of accurately assessing eye gaze, video images are manually processed to obtain data relating to changes in gaze direction. Head motion is estimated using optical flow and block matching techniques whereby optical flow vectors are calculated for different face regions over each frame in the time window being considered (one or two second moving windows). The vectors are then input into a classifier aimed at capturing rapid head movements. They track lane changes using the VioLET lane tracker proposed by [14] to make predictions based upon the

selected cues. Results from this study showed that driver head motion when combined with lane position and vehicle dynamics is a reliable cue for lane change intent. They say that the use of eye gaze changes to predict lane change is slower than using head movements as head movements tend to occur before changes to eye gaze.

III. ROC ANALYSIS

The following procedure was used to assess the effectiveness of the eye-gesture template approach for driver point of regard determinations. The experimental method was based upon the approach of [6]. The aim of the experiment was to use eye-gesture templates to determine the driver's point of regard on the windscreen of a Ford Focus 1.6cc car. Firstly, the windscreen of the car was divided into 24 cells consisting of 4 rows of 6 columns with each cell approximately 16cm wide and 15cm high. Figure 1 shows an image of the car with the windscreen cells marked out with masking tape. A Thorlabs DCC1545M CMOS camera was placed underneath the internal mirror and aligned to capture the driver's upper body and face. The camera was positioned so as to be able to capture the driver's face during the full range of driving positions.

To create eye-gesture templates, the driver was asked to look at the centre of each windscreen cell while keeping her head-pose fixed in a neutral forward facing position. When the driver's eyes were focused on the centre of each windscreen cell, an eye-gesture template was captured of the driver's left eye. The eye images were then cropped to contain a small amount of skin surrounding the eye. With 24 windscreen cells, there were 24 corresponding eye-gesture templates. Figure 2 shows all 24 eye-gesture templates.



Fig. 1 The windscreen of the Ford Focus car divided into 24 cell

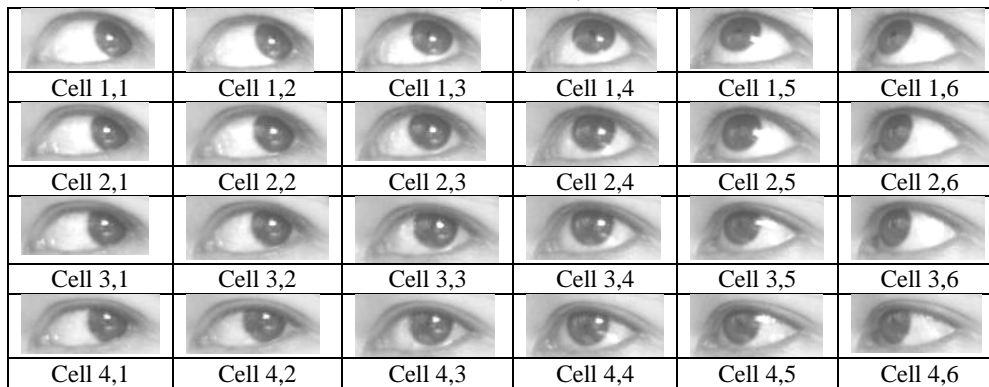

Fig. 2 Eye-gesture templates of the driver's left eye looking at the centre of each windscreen cell



Fig. 3 Test driver looking at the centre of cell(2,1) of the windscreen

A video of the driver was then captured as she looked at each windscreen cell in turn for a period of approximately 10 seconds. Figure 3 shows an image of the driver looking at windscreen cell(2,1) captured from the on-board camera. While focusing on each cell, the driver varied her point of regard randomly over the cell while keeping her point of regard within the boundary of the cell. This means that the driver's point of regard spanned the whole area of the cell and often came close to the boundary between neighbouring cells.

The 'Eye-Analyse' eye-tracking system produced by Eye Tracking Analysts Ltd (www.eyetrackinganalysts.com) was used to perform template matching on each frame of the video using all 24 eye-gesture templates with a normalised correlation coefficient matching algorithm. The Eye-Analyse eye-tracker system includes an implementation of the eye-gesture template approach to eye-detection and low resolution eye-tracking. Template matching was performed on the entire image using all 24 eye-gesture templates and the highest matching template together with the percentage match result was recorded for each frame.

The accuracy of the algorithm was analysed using Receiver Operating Characteristic (ROC) analysis using IBM's Statistical Package for the Social Sciences (SPSS) software. The ROC analysis was used to estimate how effective the template matching algorithm was at determining the driver's

point of regard on the windscreen with eye-gesture templates drawn from images of the driver looking at the centre of each windscreen cell. In order to achieve this, the highest template matching result for each frame of the driver video together with a classification of whether the result was correct was entered into SPSS based upon a ground truth established by a human expert.

IV. THE ROC CURVE

A ROC analysis was performed to assess how effective the eye-gesture template algorithm is at determining which windscreen cell the driver is focusing on. Figure 4 shows the ROC curve where the true positive rate (sensitivity) is plotted against the false positive rate (1-Specificity). The optimal threshold value for the template matching algorithm was estimated to be 0.972 based upon Youden's J index [16] which is based upon (1):

$$J = \max (Sensitivity_c + Specificity_c - 1) \quad (1)$$

where c ranges over all possible criterion (threshold) values. In the ROC curve of Figure 4, J is the maximum vertical distance between the ROC curve and the diagonal line. The corresponding sensitivity at this threshold was 0.859 and the corresponding specificity was 0.595.

The true positive rate reflects how well the eye-gesture template algorithm can correctly identify the driver's point of regard by determining which windscreen cell the driver is looking at in each video frame. The true negative rate reflects how well the algorithm can correctly identify that the driver is not looking at a windscreen cell by determining situations where her point of regard is focused elsewhere.

A sensitivity of 0.859 means that the algorithm can detect which windscreen cell the driver is looking at with an 85.9% success rate even when the driver's point of regard spans the entire cell up to the boundary between neighbouring cells. However, the results gives a 0.405 true negative rate which means that the algorithm can only detect if the driver is not looking at a windscreen cell with a 40.5% success rate.

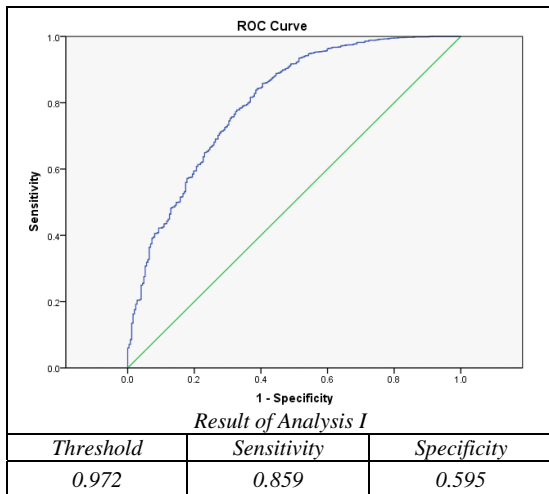

Fig. 4 The ROC curve based upon all 24 windscreen cells

Table I below shows the number of video frames in which the driver was looking at each cell. For instance, there was 114 frames where the driver was looking at cell (1,1). Table II shows the number of misclassifications for each cell where the numbers within the table are positioned toward the top, bottom, left or right of the cell to indicate the neighbouring cell that was incorrectly identified during template matching. The number itself indicates the frequency of the misclassification. For instance, the driver’s point of regard on windscreen cell (1,1) was incorrectly classified as a point of regard on windscreen cell(1,2) 16 times and incorrectly classified as windscreen cell (2,1) 1 time. The driver’s point of regard on windscreen cell (1,2) was incorrectly classified as a point of regard on windscreen cell (1,1) 10 times, cell (1,3) 1 time and cell (2,2) 2 times.

TABLE I
NUMBER OF FRAMES DRIVER LOOKS AT EACH WINDSCREEN CELL

Cell	1	2	3	4	5	6
1	114	109	113	112	124	91
2	107	86	99	107	104	109
3	94	109	109	91	85	107
4	30	149	75	84	96	121

TABLE II
THE NUMBER OF CELL MISCLASSIFICATIONS. (NOTE THAT THE NUMBERS IN THE CELLS SHOW THE NUMBER OF TIMES THE CELL HAS BEEN MISCLASSIFIED AND ARE POSITIONED ADJACENT TO THE CELL THAT WAS INCORRECTLY IDENTIFIED DURING TEMPLATE MATCHING)

Cell	1	2	3	4	5	6
1		16 1	1 2			1
2	2		4 8	1 9	10	3
3	3 6	1 10		5 2	1 4	2 4
4		4 47			1 2	5

Inspecting the misclassifications from the eye-gesture template matching algorithm in Table I and the ground truth showed that many of the misclassifications happened within windscreen columns one and two. This was due to the fact that the test driver could not comfortably look at the cells in column one while keeping her head in the neutral forward facing position. This means the eye-gesture templates for the cells in column one are very similar to the eye-gesture templates for the cells in column two. It also meant that, in the test video, the driver’s point of regard within column one remained very close to the boundary with column two simply because the driver could not physically look to the left of the cells in column one while keeping her head in the neutral, forward facing position.

Another factor that sometimes led to misclassification by the eye-gesture template algorithm was that the test driver was asked to vary her point of regard within each cell and this often resulted in the driver’s point of regard coming very close to the boundary of a neighbouring cell. For example, if the driver is looking at cell(2,5), the algorithm would sometimes classify the driver as looking at the cell(3,5) which is located directly under cell (2,5). This is due to the similarity of the driver’s eye pattern with the template for cell(3,5) as she focused her point of regard on the boundary between these cells.

Yet another factor leading to misclassification was occasions when the driver’s eyes were squinting or blinking leading to misclassification with a low percentage match from the eye-gesture template.

A. The ROC Curve without Windscreen Columns One and Two

Examining Table II shows that there is frequent misclassification for column one and two on the windscreen. This is because the test driver could not fully look at the full area within the boundary of the cells in column one while keeping her head in the neutral, forward facing position. A qualitative inspection of the first two columns of eye-gesture templates in Figure 2 will show that the iris position between column one and two is more closely spaced than for any other consecutive columns. Table II show that this problem was particularly significant for cell(1,1) which was misclassified as cell(1,2) 16 times, cell(1,2) which was misclassified as cell(1,1) 10 times and for cell(4,2) which was misclassified as cell(4,1) 47 times.

Due to the driver’s difficulty in looking at column one on the windscreen while keeping her head in a neutral, forward facing position, it was decided to perform ROC analysis on the data without columns one and two. Therefore windscreen cells (1,1), (1,2), (2,1), (2,2), (3,1), (3,2), (4,1) and (4,2) were removed from the data.

The Figure 5 shows the corresponding ROC curve with the optimal threshold of 0.9721 estimated using Youden’s J index. The true positive rate and true negative rate corresponding to this optimal threshold was found to be 0.843 (true positive) and 0.850 (true negative). This is comparable with the sensitivity value of 0.859 presented in Figure 4 for data containing the first two windscreen columns. However, the true negative rate (specificity) is 0.850 compared to value of

0.595 presented in Figure 4 for the analysis containing the first two windscreen columns.

This means that the eye-gesture template approach in this experiment could identify which windscreen cell the driver was focusing on with an 84.3% success rate and could correctly identify if the driver was not looking at a particular cell with an 85.0% success rate.

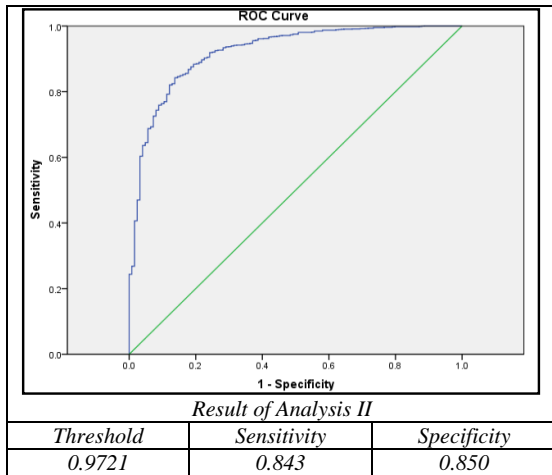

Fig. 5 ROC curve without data for first two windscreen columns

B. The ROC Curve without Windscreen Columns One and Two and without Squinting and Blinking

ROC analysis was repeated on the test data with data for windscreen columns one and two removed and without data where the driver's eyes were squinting (partially closed) or blinking (closed). The resulting ROC graph is shown in Figure 6. Here we see that the sensitivity 0.843 which is the same as for the previous analysis shown in Figure 5. The specificity is 0.799 (slightly lower than for Figure 5).

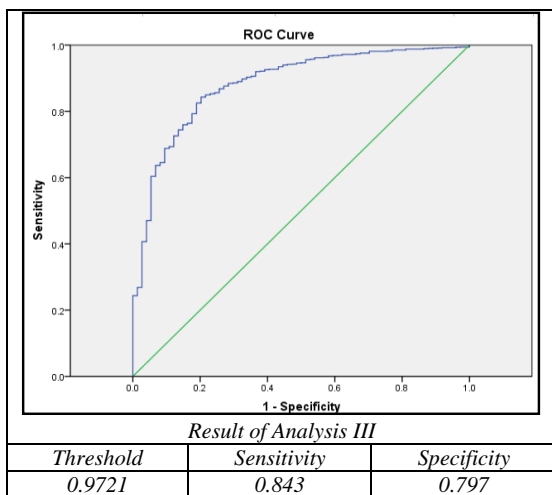

Fig. 6 ROC curve without data for first two windscreen columns and without frames where the driver is squinting or blinking

V. ERROR CALCULATIONS

The aim of the second experiment was to estimate the ability of the eye-gesture template approach to distinguish between points at varying distances from the driver's actual point of regard.

The experiment involves creating three windscreen cells centered on a point of regard. The centre of the rectangles was chosen to be 27cm from the left edge of the windscreen and 23.5cm from the top edge of the windscreen. The inner rectangle had a width of 8cm and height 7cm high. The middle rectangle had a width of 16cm and a height of 14cm. The outer rectangle had a width of 24cm and a height 21cm. An eye-gesture template was created of the driver looking at the mid-point of each side of the three rectangles and at the central point of regard. This gave a total of thirteen eye-gesture templates. Figure 7 below gives an illustrative view of the three rectangles with the thirteen eye-gesture template focal points represented by white circles. In Figure 7, there are four outer eye-gesture template focal points: O1, O2, O3 and O4. There are four corresponding middle eye-gesture template focal points: M1, M2, M3 and M4. There are four inner eye-gesture template focal points: C1, C2, C3 and C4. Lastly, there is one central eye-gesture template focal point, C.

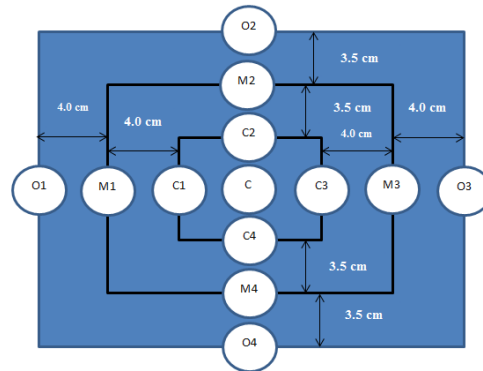

Fig. 7 Three rectangular windscreen cells with thirteen eye-gesture template focal points illustrated with white circles

In order to create the driver's eyes gesture templates, the driver was asked to look at the thirteen eye-gesture template focal points and an image of the left eye was captured and cropped to include the eye and a small amount of skin surrounding the eye. Figure 8 shows the thirteen eye-gesture templates.

A video of the driver's left eye was recorded as she focused her attention on the central point C for a total of 388 frames. The Eye-Analyse eye-tracking system produced by Eye Tracking Analysts Ltd (www.eyetrackinganalysts.com) was used to perform template matching with a normalised correlation co-efficient matching algorithm so as to determine which of the thirteen eye-gesture templates represented the best match for each frame of the driver video. For each frame, the highest matching template and the corresponding percentage match was recorded.

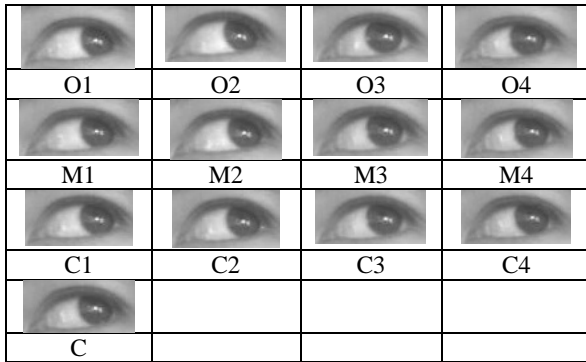

Fig. 8 Thirteen eye-gesture templates used in error experiment

Table III gives the total number of frames for which each of the eye-gesture templates was matched within the video of the driver fixating her gaze on the central point C. The probability that the eye-gesture template will match with the driver's left eye was estimated based upon the total number of times the template was matched divided by the total number of frames in the driver video. Inspecting Table III, it can be seen that the highest matching template is for C which corresponds to the driver focusing on the central focal point with a probability of approximately 0.5979 and the next highest matching template is C4 with a probability of approximately 0.1237. This result indicates that the eye-gesture template matching algorithm is able to distinguish between eye-gesture templates created for points of regard located 3.5cm apart approximately 60% of the time.

TABLE III
APPROXIMATE PROBABILITY OF MATCH OF EYE-GESTURE TEMPLATES
WITHIN VIDEO FRAMES OF DRIVER FIXATING ON WINDSCREEN POINT C.

Windscreen Cell Focal Point	Total of errors (out of 388 frames)	Approximate Probability
O1	3 frames	0.0077
O2	0 frames	0.0000
O3	0 frames	0.0000
O4	23 frames	0.0592
M1	0 frames	0.0000
M2	0 frames	0.0000
M3	3 frames	0.0077
M4	47 frames	0.1211
C1	15 frames	0.0386
C2	17 frames	0.0438
C3	0 frames	0.0000
C4	48 frames	0.1237
C	232 frames	0.5979

Considering the four focal points on the inner windscreen cell, C1, C2, C3, and C4, we see that the eye-gesture template matching algorithm will match with an inner cell template with an approximate probability of 0.2061.

Considering the middle windscreen cell eye-gesture templates, M1, M2, M3 and M4, the eye-gesture template matching algorithm will match with a middle cell template

with an approximate probability of 0.1288. A similar calculation for templates based upon the focal points on the outer windscreen cell, O1, O2, O3 and O4, gives an approximate probability of a 0.0669.

VI. CONCLUSION

The ROC analysis presented in this paper has given some indication of the utility of the eye-gesture template approach for driver point of regard determinations. The sensitivity and specificity values for the ROC curve produced in Figure 5 were 0.843 and 0.850 respectively. This seems to suggest that the eye-gesture template may be effective in determining driver point of regard given that the algorithm can determine the driver's current focus of attention over a coarse grid of windscreen cells with an 84.3% success rate and can determine negative cases with an 85.0% success rate. Hence the results indicate that it is possible to use the eye-gesture template approach in order to distinguish between the driver's points of regard on the windscreen. Our error experiment has shown that given eye gesture templates created for edge centre points of three overlapping rectangles of dimensions 8cm*7cm, 16cm*14cm and 24cm*21cm centered on a point 27cm from the left edge of the windscreen and 23.5cm from the top edge of the windscreen, the probability of a template match for the actual centre point and points on the middle of the sides of the outer, middle and inner cells is 0.5979, 0.0669, 0.1288 and 0.2061 respectively. This gives a rough indication of the accuracy of the eye-gesture template approach to distinguish between points on the windscreen that are at varying distances from the driver's actual point of regard..

We plan to measure gaze detection accuracy of the driver's point of regard using a range of eye-gesture templates for different drivers and to assess the impact of head movements on the accuracy of the approach.

ACKNOWLEDGMENT

The authors would like to thank our friend Dr John Cox for proof reading this paper.

REFERENCES

- [1] Fletcher, L., and Zelinsky, A., 'Driver Inattention Detection Based on Eye Gazed - Road Even Correlation', The International Journal of Robotics Research, pp.774-801, June 2009.
- [2] WHO, 'World Health Report, Technical Report', World Health Organisation, <http://www.who.int/whr2001/2001/main/en/index.html>, 2001.
- [3] OECD/ECMT, 'Ambitious Road Safety Targets and the Safe System Approach', OECD Publishing, 2006.
- [4] Department for Transport Statistics, Retrieved September 20, 2012, from the Department for Transport: http://www.dft.gov.uk/statistics?orderby=date&post_type=table&series=road-accidents-and-safety-series, 2010.
- [5] MohdZaid, S.N.H., Mohamed, A.M., Soliman, A.H., 'Towards EyeGesture Analysis for Driver Assistance Systems using Template Matching, Proceeding of 4th Engineering Conference (EnCon), Kuching, Sarawak, Malaysia, 2011.
- [6] MohdZaid, S., N., H., Mohamed, A.M., and Soliman, A.H., 'EyeGesture Analysis for Driver Hazard Awareness', World Academy of Science, Engineering and Technology (WASET), Tokyo, Japan, Vol.65, pp.1240-1246, 2012.
- [7] MohdZaid, S., N., H., Mohamed, A.M., Soliman, A., H., 'Eye Gesture Analysis with Head Movement for Advanced Driver Assistance

- Systems', World Academy of Science, Engineering and Technology (WASET), France, Vol 66, pp. 1082- 1088, 2012.
- [8] Dingus, T.A., Klauer, S.G., Neale, V.L., Petersen, A., Lee, S.E., Sudweeks, J., 'The 100-car Naturalistic Driving Study, Phase II- results of The 100 Car-Field Experiment (Technical Report No DOT HS 810593)', Washington, DC-NHTSA, 2006.
- [9] Klauer, S.G., Dingus, T.A., Neale, V.L., Sudweeks, J., and Ramsey, D., 'The impact of Driver Inattention on Near-Crash/Crash Risk : An Analysis Using the 100-car Naturalistic Driving Study Data (Technical Report No. DOT HS 810 594)', Washington DC: NHTSA, 2006.
- [10] Fletcher, L., Loy, G., Barnes, N., and Zelinsky, A., 'Correlating Driver Gaze with Road Scene for Driver Assistance Systems', Journal of Robotics and Autonomous Systems, pp.71-84. 2005a.
- [11] Fletcher, L., Petersson, L., Barnes, N., Austin, D., and Zelinsky, A., 'A Sign Reading Driver Assistance System Using Eye Gaze', Proceedings of the IEEE International Conference on Robotics and Automation, pp.4655- 4660.
- [12] Gee, A.H. and Cipolla, R., 'Determining the Gaze of Faces in Images', Image and Vision Computing, Vol.12, No.10, pp. 639-647, 1994.
- [13] Cheng, S.Y., and Trivedi, M.M., 'Towards a Comparative Study of Lane Tracking Using Omni-directional and Rectilinear Images for Driver Assistance Systems', ICRA, Workshop: Planning, Perception and Navigation for Intelligent Vehicles, 2007.
- [14] McCall, J.C. Wipf, D.P., Trivedi, M.M., Rao, B.D., 'Lane Change Intent Analysis Using Robust Operators and Sparse Bayesian Learning', IEEE Transaction on Intelligent Transportation Systems, Vol.8, No.3, pp.431-440, 2007.
- [15] Doshi, A., and Trivedi, M., 'On the Roles of Eye Gaze and Head Dynamics in Predicting Driver's Intent to Change Lanes', IEEE Intelligent Transportation Systems, Vol.3, No.10, pp.453-462, 2009.
- [16] Youden W., J., 'An Index for Rating Diagnostic Tests'. Cancer vol.3 pp.32-35, 1950.