

An Improved Tie Force Method for Progressive Collapse Resistance of Precast Concrete Cross Wall Structures

M. Tohidi, J. Yang, C. Baniotopoulos

Abstract—Progressive collapse of buildings typically occurs when abnormal loading conditions cause local damages, which leads to a chain reaction of failure and ultimately catastrophic collapse. The tie force (TF) method is one of the main design approaches for progressive collapse. As the TF method is a simplified method, further investigations on the reliability of the method is necessary. This study aims to develop an improved TF method to design the cross wall structures for progressive collapse. To this end, the pullout behavior of strands in grout was firstly analyzed; and then, by considering the tie force-slip relationship in the friction stage together with the catenary action mechanism, a comprehensive analytical method was developed. The reliability of this approach is verified by the experimental results of concrete block pullout tests and full scale floor-to-floor joints tests undertaken by Portland Cement Association (PCA). Discrepancies in the tie force between the analytical results and codified specifications have suggested the deficiency of TF method, hence an improved model based on the analytical results has been proposed to address this concern.

Keywords—Cross wall, progressive collapse, ties force method, catenary, analytical.

I. INTRODUCTION

FOLLOWING the partial failure of a precast concrete building located in London, Ronan Point apartment, in 1968, the British Standards [1] for concrete structures started to incorporate provisions to deal with the problem of progressive collapse. To reduce the risk of progressive collapse a 3-year research was conducted by Popoff Jr, A [2]. Portland Cement Association (PCA) [3] conducted a series of comprehensive investigations to form an underpinning knowledge basis supporting the stipulated minimum detailing requirements to retain the integrity in the event of any local damage. These attempts led to a tie-force (TF) design method adopted in British Standard, for the first time, being known in the world.

This method, which is mainly of prescriptive nature, requires the inclusion of longitudinal, transverse, vertical, and peripheral ties to provide different “alternative load resistance [1]-[5] mechanism”, e.g. catenary, cantilever, vertical, and

diaphragm actions, in a loss of underlying wall support. The study reported in this paper includes an analytical simulation of the catenary action in floor-to-floor assemblies. This action is facilitated through longitudinal ties embedded in the cast in-situ grout contained in the keyways of floor slabs (Fig. 1).

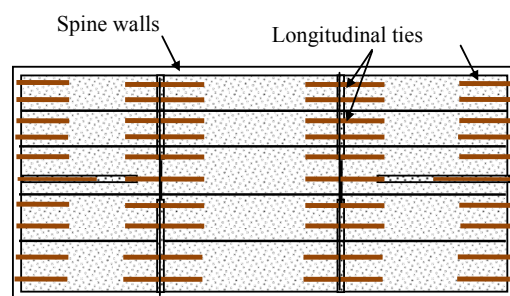

(a) Cross wall system with longitudinal ties

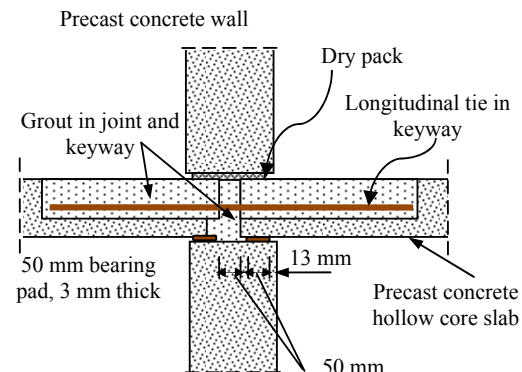

(b) Typical section view of joint

Fig. 1 Examples of precast concrete wall construction

These prescriptive tie requirements may have proven adequate in engineering practice but are not scientifically justified [4], so substantial efforts are still needed to improve the understanding, at a fundamental level [5], of how the post-collapse resistance mechanism are developed through these tie provisions. This need has also been echoed by a number of researchers in the last decade. Dusenberry [6] indicated the necessity of a better understanding of the mechanism how the progressive collapse can be resisted. To show the adequacy of codified methods for the progressive

M. Tohidi is with the School of Civil Engineering, the University of Birmingham UK, on leave from Azad University of Sanandaj (phone: 121-414-5152, e-mail: mxt995@bham.ac.uk).

J. Yang is with the School of Naval Architecture, Ocean and Civil Engineering, Shanghai Jiao Tong University, Shanghai, 200240, P.R. China, on leave from the School of Civil Engineering, University of Birmingham, Edgbaston, Birmingham, B15 2TT, U.K. (e-mail: j.yang.3@bham.ac.uk).

C. Baniotopoulos is with the School of Civil Engineering, University of Birmingham, Edgbaston, Birmingham, B15 2TT, UK (e-mail: c.baniotopoulos@bham.ac.uk).

collapse, an evaluation on three well known collapsed building cases was performed by Nair [7] based on five current codes and standards. Results revealed that almost all three studied structures are susceptible to progressive collapse. Abruzzo et al. [8] has also indicated an inadequacy of the TF method to prevent progressive collapse of structures. The necessity of developing an improved TF method has also been recommended by DoD [9]. To investigate the efficiency of TF design method, Li et al. [10] also conducted comprehensive numerical studies on two reinforced concrete (RC) structures of 3 and 8 stories, respectively; results were verified by the experimental work of Yi et al. [10]. The numerical results revealed that the current tie force method cannot provide safeguard to progressive collapse for all RC structures that have different number of stories and experience damages in different locations; accordingly, an improved TF method was proposed. Although Yagust, V. I. and Yankelevsky, D. Z [11] using analytical method concluded that the two way slab will provide more robustness. According to computational model for full and partial damage of single or multiple adjacent columns in disproportionate collapse analysis via linear programming, Gerasimidis, S., Simos, C. D. & Baniotopoulos, C. C [12] suggested that removing two adjacent columns will provide more strength against to progressive collapse.

Based on the new knowledge related to the design of buildings to resist progressive collapse using test results and analytical models, DoD [13] has undertaken significant revision to TF method in its latest version of DoD [9] and British standard [1], which requires tie strength four time more than previous TF method specification.

TF method does not take into account the effect of bond behavior and its influencing factors between ties and surrounding grout. Those influencing factors include the strand-grout interface characteristics, stress-slip relationship and the interfacial properties e.g. diameter, elastic modulus, and embedment length, of tie bars/strands. Accordingly, it can be considered as an overly simplified method. This method is suitable for hand calculations and results are inevitably rather rough. Recently, the alternative load path method has become more popular. In this method, following the removal of a critical element due to an abnormal loading, the structure should be capable of redistributing load to the remaining undamaged structural elements. To address the abovementioned inadequacy in the TF method, these studies aims at developing an analytical method with a particular attention to the post bond-failure behavior of tie strands in the floor-to-floor joints of cross wall structures considering these influencing factors and use the obtained results to evaluate the adequacy of current TF method as recommended by most codes of practice.

II. CATENARY ACTION MECHANISM

According to the current code specifications, in order to prevent the progressive collapse for building structures, four types of alternative load resistance mechanisms should be provided, i.e.

- catenary action of floor-to-floor system,
- cantilever and beam action of wall panels,
- vertical suspension of wall panels, and
- diaphragm action of the floor plans.

In this study, to evaluate the adequacy of TF method only the catenary action of floor-to-floor systems is considered (Fig. 2), so it is assumed that all other load paths have been effectively provided.

If an underlying wall support is suddenly removed due to an abnormal load, in order to bridge out the load exerted by floor and the upper walls and hence retains the structural integrity, a continuity requirement at the floor-to-floor joints must be provided so that an alternative load path can be found. Unlike the normal service condition, a much larger deformation in the affected zone is tolerated. Therefore, the ductility of these connections is essential to satisfy the deformation demand. In precast cross-wall constructions, these requirements can be facilitated by the longitudinal tie strands/bar embedded in the cast in-situ grout placed in keyways (Figs. 1 (b) and 2 (a)). After an underlying wall support is removed, the grout at the end gap will be crushed at the early stage under the increased loads and these ties will experience tensile forces and develop large deflection in floor slabs. This process forms a catenary action mechanism (Fig. 2).

An equilibrium equation of the catenary system can be derived by taking moments about the side support in the free body diagram of the half system shown in Fig. 2 (b).

$$F_l = \frac{wb_p l_b^2}{2\delta_s} + \frac{\alpha q b_p l_b}{2\delta_s} \quad (1)$$

$$\text{let } q = w l_b, \quad F_l = (1 + \alpha) \frac{wb_p l_b^2}{2\delta_s} \quad (2)$$

where:

w = uniformly distributed load (including dead and imposed loads)

b_p = spacing of ties

l_b = floor span length

F_l = force in the longitudinal tie joining adjacent slabs

δ_s = vertical displacement at the middle wall support

q = line load exerted by the upper wall

α = percentage increase of the line load considering the number of storey [1].

Based on the compatibility condition of deformation in Fig. 2:

$$\delta_l = \sqrt{l_b^2 + \delta_s^2} - l_b \quad (3)$$

$$\delta_l = l_b \left(\sqrt{1 + (\delta_s / l_b)^2} - 1 \right) \quad (4)$$

$$\text{if } \left(\frac{\delta_l}{l_b} \right) \ll 1 \quad \frac{\delta_l}{l_b} = \frac{1}{2} \left(\frac{\delta_s}{l_b} \right)^2 \quad (5)$$

where δ_l represents the increase in the length of each floor slab, which consists of the extension of ties at both ends of the floor slab. If we use δ_{ls} and δ_{lm} to represent the extension experienced at the side and middle supports of one of the affected floor slabs, we have

$$\delta = \delta_{ls} + \delta_{lm} \quad (6)$$

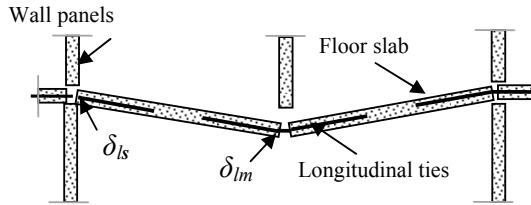

(a) Damage affected

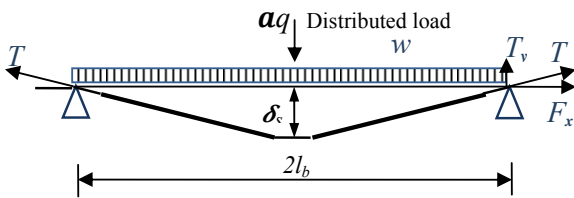

(b) Idealized catenary system

Fig. 2 Catenary action mechanisms facilitated by longitudinal ties

III. TIE FORCE METHOD

Based on British Standard [1], the TF method requires that in each direction, ties should be designed to carry a tensile force of P (kN/m) equal to the greater of the following two values:

$$P_1 = \frac{(g_k + q_k) l_b}{7.5} F_t \quad (7)$$

$$P_2 = F_t \quad (8)$$

where:

$(g_k + q_k)$ is the sum of the characteristic dead and imposed floor loads (in kN/m^2);

F_t is the lesser of $(20 + 4n_o)$ or 60 kN/m, where n_o is the number of storey;

l_b is the length of the floor span.

As stated previously, while DoD [9] had employed the same TF method to British Standard [1], DoD [13] has developed a new TF method that contains dramatic change to the current TF method. According to DoD [13], the required tie strength F_t (lb/ft or kN/m) in the longitudinal or transverse direction is

$$F_t = 3w_F L_1 \quad (9)$$

where:

$$w_F \text{ (floor load)} = 1.2D + 0.5L$$

D = dead Load

L = live Load

L_1 = either the greater of the distances between the centers of the walls supporting any two adjacent floor spaces in the longitudinal direction or the lesser between $5h_w$ and the building width in the transverse direction (ft or m)

h_w = clear story height (ft or m).

As can be seen obviously, DoD's tie strength requirement significantly higher than British Standard [1], which indicates that the current TF method in British Standard is considerably inadequate.

IV. PULLOUT LOAD-SLIP SIMULATION IN THE FRICTION STAGE

To study the behavior of a precast floor-to-floor system following the removal of wall support, in particular, to examine the effect of longitudinal tie, four full scale floor-to-floor tests were performed by PCA [3]. The results revealed that the catenary mechanism can be established when $5\% \leq \delta_s / l_b \leq 15\%$,

where δ_s is the vertical deflection at the mid-joint point, and l_b is the span length. By using (5) in the above limit of safe catenary mechanism, the pullout displacement at each end can be calculated to be $\delta_l = 0.0056l_b$. This requirement, together

with the pullout test results, suggests that the catenary action mechanism can only be developed in the post-debonding stage experienced by the tie strands in concrete. Therefore, in this paper, the pullout load-displacement relationship is developed only for the friction stage.

To analyze the post-failure behavior of floor-to-floor joints, the relationship between the longitudinal tie force with the external load and the resulting vertical deflection can be derived through the equilibrium (2). As there are two unknowns involved, another relationship between the tie forces and the slip should be developed through the pullout process of the strand in the grout. By solving two non-linear equations simultaneously, a method to analyze the floor-to-floor joint following removing an underlying wall support is developed.

A comprehensive literature review on the relationship between the pullout load and slip between the steel bar and its surrounding concrete has been conducted in last three decades [14]-[21]. Naaman et al. [15] developed a mathematical model that predicted the bond response of straight and smooth bars embedded in a cementitious matrix and subjected to a pullout load. It was assumed that the relationship between the pullout load and slip depended on the bond stress-slip relationship for the bars in the reinforced concrete or strands in the pre-stressed concrete, as was studied by Edwards and Tannopoulos, Eligehausen et al and Nilson [15]. Abrishami and Mitchel [19] developed pullout load-slip considering two linear bond-slip model. The current model has been developed considering conceptual model and main assumptions developed by Stocker and Sozen [14] and the process which was used by Naaman et al. [15] and Abrishami and Mitchell [19].

Strands constitute a group of wires rotated in a helical form around a straight centre wire. Because of the geometry of strand, the actual stress between strand and concrete will be more complicated than the plain wire [14], and [21]. A simple analysis model that can link the bond of the strand with that of plain wires for both initial bond and sliding stages was developed by Stocker and Sozen [14]. To simplify the modeling process, it was assumed that the strand can be considered as a round bar with several lugs protruding from its surface and it is assumed that only the lug is bonded to the concrete and lugs run helically around bar surface by angle of α in relation to the horizontal axis of the bar (Fig. 3).

According to the pullout test results of PCA [3], the assumption of constant bond shear stress after the bond strength τ_{\max} is reached at a large slip is not valid. Thus, it is assumed that after τ_{\max} the shear stress starts decreasing with the slip (Fig. 4 (a)). Accordingly, a more complex pullout-slip relationship was assumed as shown in Fig. 4 (b), where the pullout versus slip curve can be divided into three zones. In zone I, there exists a perfect bond between the strand and the grout, and thus the behavior can be assumed elastic. In zone II, the debonding is initiated at P_1 and it continues till P_2 , where the full debonding occurs and the influence of friction increases. The mechanical interlocking and friction contributes to the bond resistance in zone III. The slip where the friction start decaying and the rapid occurrence of pullout is induced can be defined as Δ_o (Fig. 4 (b)). Following Δ_o , a full debonding failure process will occur and only the friction resistance is available to contribute the bond resistance. Although Δ_o can be analytically determined, in these study it is assumed to be $1.5\Delta_b$, where Δ_b is the slip at the peak pullout load P_b .

To develop the relationship between the tie force and the slip in the friction stage, an infinitesimal section of strand, d_x subjected to a horizontal pullout load P is considered (Fig. 3 (b)). In this model, the effect of torsional stiffness of the strand is neglected. In the ascending loading phase, when the applied load is small, the mechanical adhesion and friction constitute the bond resistance. After the debonding propagates along the entire length of strand, a dynamic mechanism of pullout is observed. As the angles of strand are considerably lower than that of ribbed bar, the wedging action of strand is weaker. In addition, in the relatively large slip region, the helical shape of wires will be distorted and the concrete between wires will be crushed. As a result, in the fully debonding zone, only friction contributes to the bond resistance. However, most researches assumed a linear-elastic relationship for the bond-slip curve up to the point where the bond strength is τ_{\max} . Following this stage, it is assumed that a full debonding phase is developed in the friction zone, with a frictional shear stress of τ_f , but in this study a frictional decay was assumed (Fig. 4 (a)).

According to Fig. 3, the following forces act on each lugs:

1. A differential pullout force dF , where dF is the load transferred from the strand to the grout over the length d_x ;
2. A normal force N acting on the inclined plane of the lugs;
3. A frictional force μN , where μ is the sliding friction coefficient between steel and concrete, which was found to be approximately 0.3 [14];
4. A lateral stress p_N due to shrinkage or externally applied pressure;
5. A friction stress τ_d due to p_N .

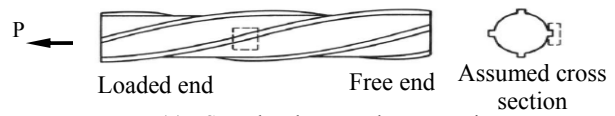

(a) Strand and assumed cross section

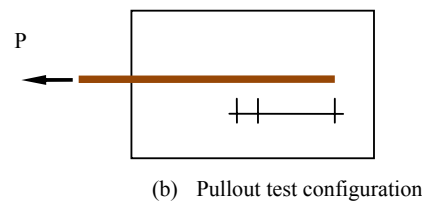

(b) Pullout test configuration

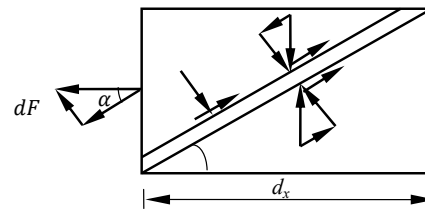

(c) Conceptual model for bond at the strand surface

Fig. 3 Free-body diagram of infinitesimal section of strand [14]

Force equilibrium in the longitudinal and perpendicular directions of the lugs (Fig. 4 (c)) leads to

$$dF = \frac{C\tau_d}{\cos^3 \alpha (1 - \mu \tan \alpha)} dx \quad (10)$$

$$\tau_d = \mu p_N \cos^2 \alpha \quad (11)$$

$$dF = \frac{C\mu p_N}{\cos \alpha (1 - \mu \tan \alpha)} dx \quad (12)$$

where p_N is a normal contact pressure between the strand and grout. Based on the Timoshenko theory [15] the interfacial contact pressure p_N with no load on strand and for $r_f \ll r_m$ is given by

$$p_N = \frac{\varepsilon_{mr}}{\frac{1+\nu_m}{E_m} + \frac{1-\nu_f}{E_f}} \quad (13)$$

where ε_{mr} is the radial shrinkage strain in the grout, which is defined as

$$\varepsilon_{mr} = \frac{\delta}{r_f} \quad (14)$$

where δ and r_f is indicated in Fig. 5. Subjected to the axial stress, the strands will be subjected to a Poisson's contraction as follow:

$$\varepsilon_f = \frac{F}{A_f E_f} \nu_f \quad (15)$$

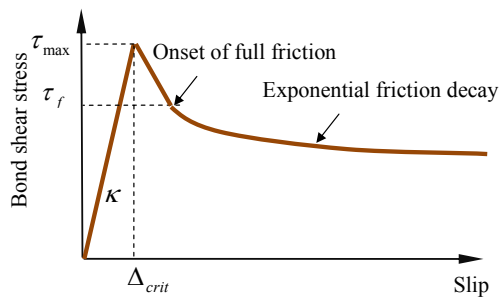

(a) Shear stress versus slip with frictional decay

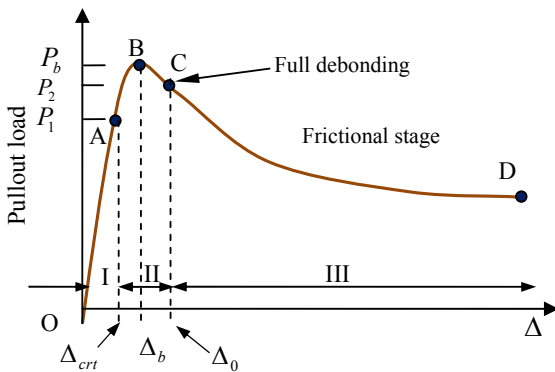

(b) Pullout load versus slip

Fig. 4 Assumed bond stress and pullout load versus slip

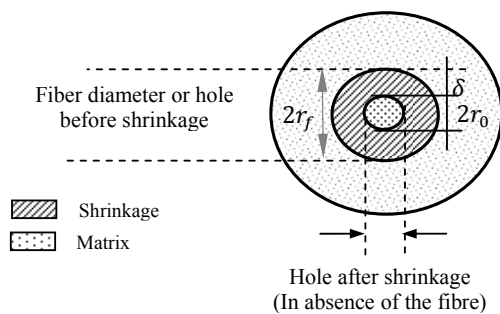

Fig. 5 Shrinkage in grout in case of absence of the strand [15]

As this strain will reduce the contact pressure on the

interface, the effective strain should be taken into consideration as follows:

$$\varepsilon_{meff} = \varepsilon_{mr} - \varepsilon_f \quad (16)$$

by substituting (13) and (14), in (16) and then in (11), one obtains

$$dF = \frac{C\mu}{R \cos \alpha (1 - \mu \tan \alpha)} \left(\varepsilon_{mr} - \frac{F}{A_f E_f} \nu_f \right) dx \quad (17)$$

where $R = (1 + \nu_m) / E_m + (1 - \nu_f) / E_f$

by solving (16), the pullout load in strand can be calculated as follows:

$$P = \frac{\varepsilon_{mr} A_f E_f}{\nu_f} \left(1 - \exp \left[\frac{-C\mu\nu_f}{R \cos \alpha (1 - \mu \tan \alpha) A_f E_f} x \right] \right) \quad (18)$$

where $x = l - \Delta + \Delta_o$. During the pullout, the quantity of δ is decreased due to the combined action of abrasion and the compaction of cement and sand particles surrounding the strand. Naaman et al. [15] have suggested an exponential function for the decreasing trend of δ for smooth bars. To best fit with the pullouts test of strand, it is modified as shown in (18). χ and γ are constants which can be defined based on the pullout test results.

$$\delta = \delta_o \frac{e^{-0.09(\Delta - \Delta_o)^\eta} - \xi e^{-(l)^\eta}}{\chi(1 - \xi e^{-(l - \Delta + \Delta_o)^\eta})(e^{0.09(\Delta - \Delta_o)^\eta})} \quad (19)$$

where

Δ_o = the end slip of the strand at the onset of full debonding,

Δ = the end slip;

δ_o = the amount of δ at the onset of full debonding;

ξ and η = the constants according the experimental tests [15]

χ and γ = the empirical constants according to the experimental tests.

In the full debonding stage, by substituting $x = l$, $P = \tau_f C l / \beta$, and $\varepsilon_{mr} = \delta_o / r_f$ to (19), δ_o is calculated as:

$$\delta_o = \frac{r_f \nu_f}{A_f E_f} \frac{\tau_f C}{\beta} l \left(1 - \exp \left[\frac{-C\mu\nu_f}{R \cos \alpha (1 - \mu \tan \alpha) A_f E_f} l \right] \right)^{-1} \quad (20)$$

V. ANALYSIS OF FLOOR-TO-FLOOR SYSTEM (CATENARY ACTION MECHANISM)

To analyze the floor-to-floor system when a support wall is removed, the catenary action mechanism must be taken into consideration. As mentioned previously, due to the high slip demand, the catenary action mechanism will be established in the full debonding zone. In this zone, the relationship between the pullout load and the slip is defined by (18). By considering

(2) and (18) and solving two simultaneous non-linear equations in terms of tie force and slip, the vertical deflection can be calculated. By replacing P in (18) with the tie force from (2), and considering $\Delta = \delta_s / 2$, we have

$$\frac{(1+\alpha)wb_p l_b^2 v_f}{2\varepsilon_{mr} A_f E_f} = \delta_s \left(\frac{1 - \exp\left(\frac{-C\mu v_f}{R \cos \alpha (1 - \mu \tan \alpha) A_f E_f}\right)}{\left(l - \frac{l_b}{4} \left(\frac{\delta_s}{l_b}\right)^2 + \Delta_o\right)} \right) \quad (21)$$

In practice, except δ_s , all other parameters are known. To simplify (21), the constant parameters of $(1+\alpha)wb_p l_b^2 v_f / (2\varepsilon_{mr} A_f E_f)$ and $C\mu v_f / [R \cos \alpha (1 - \mu \tan \alpha) A_f E_f]$ is replaced by D and Z , respectively. Thus (21) can be rewritten as follows:

$$D = \delta_s \left(1 - \exp\left[-Z \left(l - \frac{l_b}{4} (x)^2 + \Delta_o\right)\right] \right), \quad x = \delta_s / l_b \quad (22)$$

by using Taylor expansion for the function of $y = \exp[-Z(l - l_b/4(x)^2 + \Delta_o)]$ for the region near $x = 0.1$ and the rearrangement of parameters leads to the following equation:

$$\begin{aligned} & [0.25Zl_b(1 + 0.005Zl_b)]x^3 - [0.00025Z^2l_b^2]x^2 + [1 + \\ & 0.0025Zl_b(-1 + 0.005Zl_b) - e^{Z(l-0.0025l_b+\Delta_o)}]x \\ & + \left(\frac{D}{l_b}\right)e^{Z(l-0.0025l_b+\Delta_o)} = 0 \end{aligned} \quad (23)$$

Following the calculation of δ_s through (23), by substituting it in (18) and (3), the tie force and slip can be determined. To satisfy the design limit, the embedment length or diameter of steel should be adjusted so that the ratio of δ_s / l_b meets the requirement. In practice, as $x \leq 0.15$, the first two expressions in (23) are considerably less than other two i.e. less than 1/100, thus they can be ignored. Then we have

$$\delta_s = \frac{\left(\frac{D}{l_b}\right)e^{Z(l-0.0025l_b+\Delta_o)}}{\left[1 + 0.0025Zl_b(-1 + 0.005Zl_b) - e^{Z(l-0.0025l_b+\Delta_o)}\right]} l_b \quad (24)$$

$$P = \frac{\left[1 + 0.0025Zl_b(-1 + 0.005Zl_b) - e^{Z(l-0.0025l_b+\Delta_o)}\right]}{2\left(\frac{D}{l_b}\right)e^{Z(l-0.0025l_b+\Delta_o)}} w b_p l_b \quad (25)$$

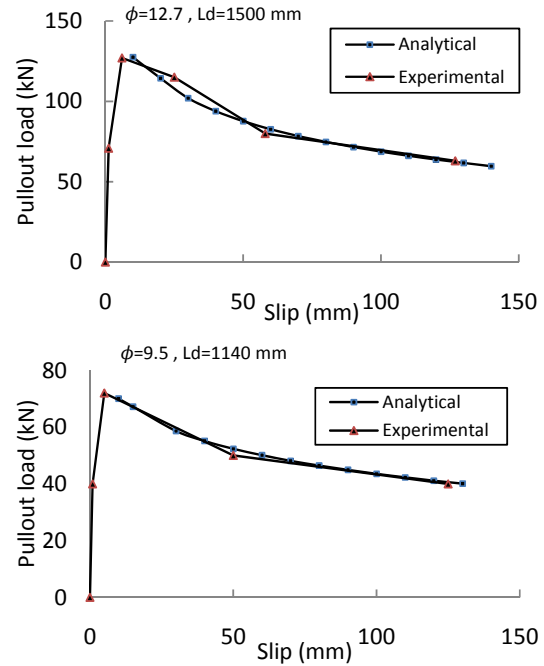

Fig. 6 Pullout load-slip for strand with different size and embedment length

VI. VERIFICATION

Based on the pullout test results, a calibration was performed to calculate the radial shrinkage strain in the grout ε_{mr} included in (18). The pullout load-slip relationship was calculated by using (18). To verify the accuracy of the solution, a comparison is performed with the full scale floor-to-floor test result under taken by PCA (1975-1979), the result of which is presented in Fig. 6.

Fig. 7 shows that the discrepancy on the maximum tie force between the analytical and the PCA [3] tests is around 7%. In the experimental work, the tie force has been calculated based on the strain gauges results, which were commonly attached to the steel strand in two discrete points adjacent to the loaded end. Furthermore, in contrast to the idealized model, the pullout behavior of strands in sides and the middle of test specimens shows different tie force versus vertical deflection relationship, which in turn results into the discrepancy. However, in this study, to develop a practical approach to analyze and design the floor-to-floor joints, the force-vertical deflection relationship at the middle and sides is assumed to be identical.

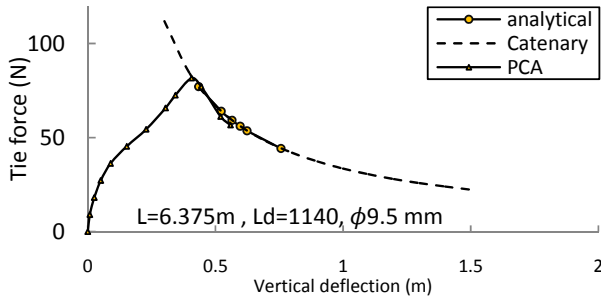

Fig. 7 Tie force versus vertical deflection at mid-joint for full scale

VII. GENERIC DISCUSSIONS AND DESIGN METHOD

To develop a generic method to design the floor-to-floor system in preventing progressive collapse, it will be more convenient to develop a series of design charts referring to a wide range parameters for tie spacing and slab length. To that end, (24) can be rewritten as follow

$$\delta_s = \varphi \frac{(1 + \alpha) w b_p l_b^2 v_f}{2 \varepsilon_{mr} A_f E_f} \quad (26)$$

where

$$\varphi = \frac{e^{Z(l-0.0025l_b+\Delta_o)}}{[1 + 0.0025Zl_b(-1 + 0.005Zl_b) - e^{Z(l-0.0025l_b+\Delta_o)}]}$$

It can be shown that for a long embedment length i.e. 760 mm, 1140, 1500 mm, the variation of ϕ is less than 6%. Accordingly, in practice, to establish a simplified analysis and design methods, this term can be ignored. Thus, we have:

$$\delta_s = \frac{(1 + \alpha) w b_p l_b^2 v_f}{2 \varepsilon_{mr} A_f E_f} \quad (27)$$

Like most codes, to establish a safe catenary action, it is usually to define a limit based on δ_s / l_b , thus (27) is rearranged as follow:

$$\delta_s / l_b = \frac{v_f}{2 \varepsilon_{mr} A_f E_f} (1 + \alpha) w b_p l_b \quad (28)$$

By following the same procedure, the tie force can be defined as:

$$P = \frac{\varepsilon_{mr} A_f E_f}{v_f} \quad (29)$$

Fig. 8 shows a significant discrepancy between TF method and proposed method. To establish a design method, tie force versus δ_s / l_b for different $w b_p l_b$ can be developed. In this study, according to three pullouts test result for strand size of 9.5mm

with the embedment length of 760mm, 1140mm and another stand size 12.7mm with the embedment length of 1500mm, three graphs were developed (Figs. 9 and 10), where the strength of system can be calculated based on various values of δ_s / l_b in the safe region $5\% \leq \delta_s / l_b \leq 15\%$. It is to be noted that, a strength factor, i.e. $\Omega = 1.25$, should be applied to $w b_p l_b$. The proposed method indicates that as long as the pullout test results are available, this method can be valid for any bar size and embedment length.

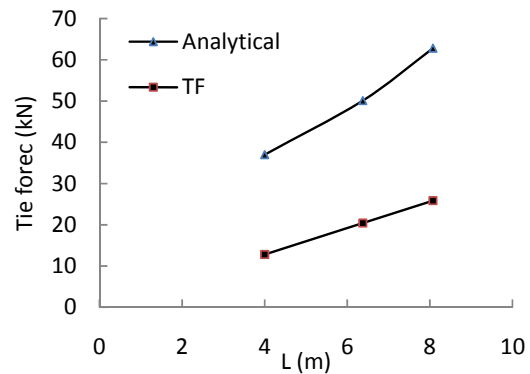
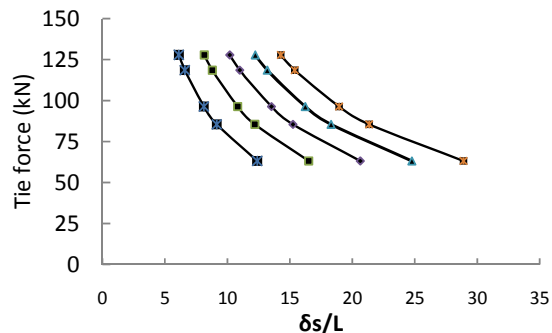
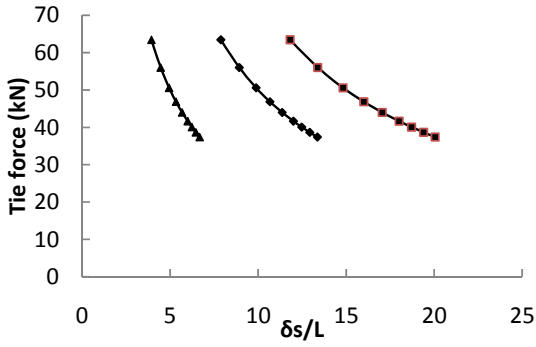

Fig. 8 Tie force versus span length

According to Figs. 9 and 10 and considering $\delta_s / l_b = 15\%$, the tie force versus length tables/charts can be derived for various strand sizes and tie configurations in the floor joints. For instance, Fig. 11 shows the tie force versus the span length for the floor load of 8.5 kN/m^2 and the strand sizes of 12.7mm and 9.5mm with two and three strands in the joint, respectively. The graph clearly shows that, the relation between the tie force and the span length is linear with an almost same gradient.

 (a) $\phi 12.7, L_d=1500 \text{ mm}$



(b) $\phi 9.5, L_d=760\text{mm}$

Fig. 9 Strength of the floor-to-floor system

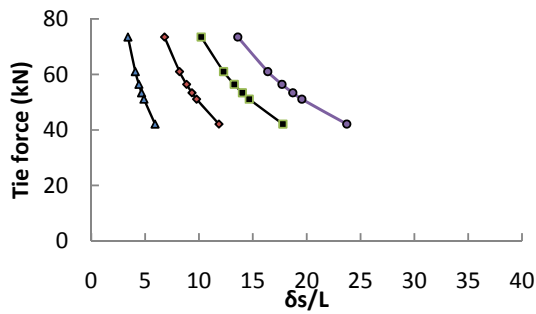

$\phi 9.5, L_d=1140\text{ mm}$

Fig. 10 Strength of the floor-to-floor system

Considering different floor loads, span lengths, and ties in joints, the minimum and maximum tie forces can be summarized as follow:

$$P = 2.62wb_p l_b \tag{30}$$

$$P = 2.94wb_p l_b \tag{31}$$

The result clearly indicates that British Standard [1] and Eurocode [22] are significantly underestimated (see (7), (8)), while shows very good agreement to DoD [13] (see (9)).

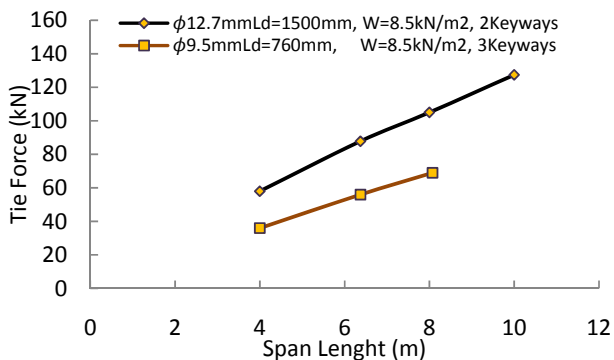

Fig. 11 Tie force versus span length

VIII. CONCLUSIONS

The tie force (TF) method is one of the most widely used methods to design concrete structures for progressive collapse. Due to the simplifications adopted in this method, it is easy for hand calculations compared to the alternate load path or other comprehensive analytical methods. In this paper, the tie force-slip (or tie force - vertical deflection) relationship is developed to reproduce the laboratory tests. The novelty of this study is that, from the design perspective, it is the ductility rather than the tie strength should be considered in the progressive collapse design. The discrepancies in the tie force between the analytical and codified specifications have suggested that an underestimate from the TF method which may lead to an unsafe design. Hence, an improved tie force method is subsequently presented, taking into account influencing factors such as the applied loads, the slab length (equal and unequal), the steel tie diameter, the embedment length, and the strand and concrete materials. The validation of the proposed models is carried out by comparing the present results to the experimental study on the full scale floor-to-floor joint and pullout tests, which shows a good agreement.

APPENDIX

A. Circumference and Cross Section of Seven-Wire Strand

The shape of seven-wire strand has shown in Fig. 12. It is assumed that the diameter of wires is ϕ and the angle of them with horizontal direction is 30° . As the angle of lugs is equal to 30° , so each wire has an arch contained within an angle of 240° or a circumference or $2\pi\phi/3$, in contact with the surrounding grout. On the other hand, only 6 outer wires are in contact with the grout, so the total circumference of strand is $4\pi\phi$, i.e. $C=4\pi\phi$. The cross sectional area of each wire is $\pi\phi^2/4$, and thus the total cross sectional will be $7\pi\phi^2/4$, i.e. $A_s=7\pi\phi^2/4$.

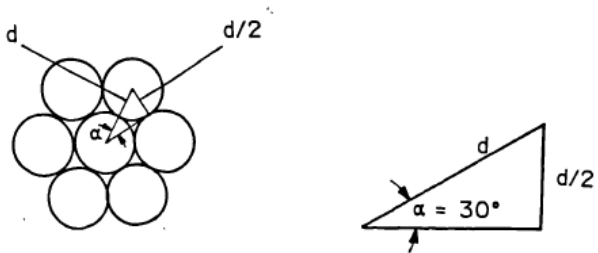

Fig. 12 The cross section of 7 wire strand

REFERENCES

- [1] British Standard. "The Structural use of concrete in building (BS 8110-11:1997)", Part 1: Code of practice for design and construction.
- [2] Popoff Jr, A., "Design against progressive collapse". PCI journal, Vol. 20, 1975, pp.44-57.
- [3] Portland Cement Association (PCA). "Design Methodology. Design and Construction of Large-Panel Concrete Structures, 1979, report 1- 6 and supplementary A, B, C.
- [4] Ellingwood, B.R., et al. (2007). Best practices for reducing the potential for progressive collapse in buildings. US Department of Commerce, National Institute of Standards and Technology.

- [5] Cleland, N.M, Structural integrity and progressive collapse in large-panel precast concrete structural systems. *PCI journal*, 53(4), 2008, p. 54-61.
- [6] Dusenberry D. "Review of existing guidelines and provisions related to progressive collapse". Workshop on prevention of progressive collapse. National Institute of Building Sciences. 2002, Washington (DC).
- [7] Nair, R. S., "Progressive collapse basics" *Modern steel construction*, Vol. 44, 2004, pp.37-44, ASCE.
- [8] Abruzzo, J., Matta, A. and Panariello, G. "Study of mitigation strategies for progressive collapse of a reinforced concrete commercial building". *Journal of Performance of Constructed Facilities*, Vol. 20, 2006, pp. 384-390.
- [9] Department of Defense (DoD). "Design Building to Resist Progressive Collapse", Unified Facilities Criteria (UFC-04-023-03), 2005, Washington, D.C.
- [10] Li, Y., Lu, X., Guan, H. and Ye, L., "An improved tie force method for progressive collapse resistance design of reinforced concrete frame structures", *Journal of Engineering Structures*, Vol. 33, 2011, pp.2931-2942.
- [11] Yagust, V. I. and Yankelevsky, D. Z. On Potential Progressive Failure of Large-Panel Buildings. *Structural Engineering (ASCE)*, 131(11), 2007. pp. 1591-1603.
- [12] Gerasimidis, S., Simos, C. D. and Baniotopoulos, C. C. (2013). A computational model for full or partial damage of single or multiple adjacent columns in disproportionate collapse analysis via linear programming. *Structure and Infrastructure Engineering*, 9(1), pp.1-14.
- [13] Department of Defense (DoD). "Design Building to Resist Progressive Collapse", Unified Facilities Criteria (UFC-04-023-03), 2013, Washington, D.C.
- [14] Stoker, M.F and Sozen, M.A. "Investigation of Prestressed Concrete for Highway Bridges; Part IV: "Bond Characteristics of Prestressing strand, University of Illinois, 1970, Structural Research Series No. 344.
- [15] Naaman, A. E., Namur, G. G., Alwan, J. M. & Najm, H. S., Fiber pullout and bond slip. I: Analytical study. *Journal of Structural Engineering*, Vol. 117, 1991, pp.2769-2790.
- [16] Den Uijl, J., "Bond modelling of prestressing strand". *ACI Special Publication*, 1998, Vol. 180.
- [17] Den Uijl, J. A. and Bigaj, A. J. "Bond model for ribbed bars Based on Concrete Confinement. *HERON*, Vol. 41, No. 3, 1996, pp.201-226.
- [18] CEB-FIP. 2000 State-of-the-Art Report on Bond of Reinforcement in Concrete. State- of- Art Report Prepared by Task Group, Bond Models (former CEB Task Group 2.5) FIB – International Federation of Structural Concrete, Féd. Int. du Béton (fib).
- [19] Abrishami, H. H. and Mitchell, D., Analysis of bond stress distributions in pullout specimens, *Journal of Structural Engineering*, Vol. 122, 1996, pp.255-261.
- [20] Lundgren, K., Three-Dimensional Modelling of Bond in Reinforced Concrete Theoretical Model, Experiments and Applications, 1999, Chalmers University of Technology.
- [21] Den Uijl, J. Year. "Bond and splitting action of prestressing strand". In: *Proceedings of the International Conference Bond in Concrete: From Research to Practice*, 1992.
- [22] Eurocode 1-Action on Structures-Part 1-7: General action- accidental Action, EN 1991-1-7:2006.