

# An Hybrid Approach for Loss Reduction in Distribution Systems using Harmony Search Algorithm

R. Srinivasa Rao

**Abstract**—Individually Network reconfiguration or Capacitor control perform well in minimizing power loss and improving voltage profile of the distribution system. But for heavy reactive power loads network reconfiguration and for heavy active power loads capacitor placement can not effectively reduce power loss and enhance voltage profiles in the system. In this paper, an hybrid approach that combine network reconfiguration and capacitor placement using Harmony Search Algorithm (HSA) is proposed to minimize power loss reduction and improve voltage profile. The proposed approach is tested on standard IEEE 33 and 16 bus systems. Computational results show that the proposed hybrid approach can minimize losses more efficiently than Network reconfiguration or Capacitor control. The results of proposed method are also compared with results obtained by Simulated Annealing (SA). The proposed method has outperformed in terms of the quality of solution compared to SA.

**Keywords**—Capacitor Control, Network Reconfiguration, Harmony Search Algorithm, Loss Reduction, Voltage Profile.

## I. INTRODUCTION

**D**UE to high load density and increased power demand, the operation of distribution systems becomes complicated. In order meet the required load demand, system must be expanded by increasing the substation capacity and number of feeders. However, this may not be easily achieved for many utilities due to various constraints. Therefore, to provide more capacity margin for substation to meet load demand, loss minimization techniques are employed. Studies indicate that about 70% of total losses occur in distribution system only [1]. There are many alternatives available for reducing losses at the distribution level of which network reconfiguration, capacitor compensation are most effective. Under normal operating conditions distribution networks are reconfigured for minimizing losses and improving the voltage profiles by changing the status of tie and sectionalizing switches. However, for heavy reactive power loads, network reconfiguration can not effectively reduce the power losses caused by reactive power flow. The fixed or switched capacitor installation can also minimize real losses and enhance voltage profiles by reducing the reactive power flow in the system. But for heavy active power loads this method is not effective. Though the objective of these two methods are same but have different properties and limitations. If these two methods are combinedly optimized, better results will certainly be obtained than that of any one method. Since network reconfiguration and capacitor placement are complex combinatorial problems,

Dr. R. Srinivasa Rao is with the Department of Electrical and Electronics Engineering, J. N. T. University Kakinada, INDIA, e-mail: kau5@in.com.

most of the authors addressed network reconfiguration without considering the capacitor installation [1]- [9], or capacitor installation problems without considering reconfiguration [10]- [17]. However, only a few papers on loss minimization using both network reconfiguration and capacitor placement had been presented. Jiang and Baldick [18] proposed Simulated Annealing (SA) algorithm in which network reconfiguration was used as master solution algorithm and capacitor control was used as slave algorithm for the combined optimization in distribution systems. Also, three search schemes, quick search, feasible search, and full search, are designed and studied. Su and Lee [19] also proposed modified SA approach for optimizing combined network reconfiguration and capacitor placement problem. In [20]- [21], Improved Genetic Algorithms (IGA) was applied to joint optimization problem by alternately performing feeder reconfiguration and capacitor control.

In this paper, HSA is proposed to minimize real power loss in the given distribution system by using both network reconfiguration and capacitor placement with. The proposed method is tested on 33 and 16 bus systems to evaluate the performance of the algorithm and the results obtained are encouraging.

The rest of the paper is organized as follows: Section II gives the problem formulation; Section III outlines Harmony Search Algorithm; Section IV provides the application of HSA for hybrid approach for loss minimization; Section V develops the test results and Section VI gives conclusions.

## II. FORMULATION OF OPTIMIZATION PROBLEM

### A. Objective function

The objective of the present optimization problem is to minimize the network power loss and maximize the voltage regulation in a given distribution system. Mathematically, the objective function is formulated as:

$$\text{Minimize } f = \sum_{i=1}^L |I_i|^2 R_i + \lambda \sum_{k=1}^n (V_k - V_s)^2 \quad (1)$$

Subject to

$$g(x) = 0 \quad (2)$$

$$\det(A) = 1 \quad \text{or} \quad -1 \quad (\text{radial system}) \quad (3)$$

$$\det(A) = 0 \quad (\text{not radial system}) \quad (4)$$

where

- $L$  - Number of branches in the system;
- $R_i$  - Resistance of branch  $i$ ;
- $I_i$  - Line current at branch  $i$  ( $i=1, 2, \dots, L$ );
- $g(x)$  - Power flow equations;
- $V_k$  - Voltage at node  $k$  ( $k=1, 2, \dots, n$ );
- $V_s$  - Voltage magnitude of Substation;
- $A$  - Bus incidence matrix;
- $n$  - Number of buses in the network;

In addition to above constraints, other constraint considered is all the loads in the system must be served. To check this constraint, routes and degree of all buses have obtained and routes of all buses need to have main bus number in first of its route.

### B. Power flow equations

The following power flows equations are derived from single-line diagram as shown in Fig. 1.

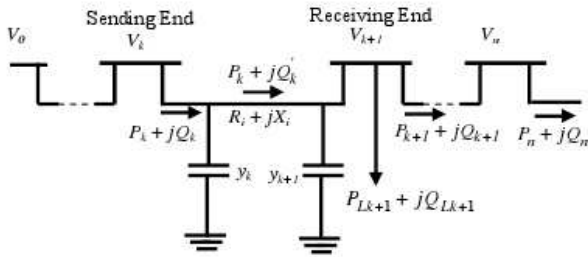

Fig. 1. Single-line diagram of a main feeder

The real power flow equation is given as

$$P_{k+1} = P_k - P_{Loss,k} - P_{Lk+1} \quad (5)$$

where  $P_{Loss,k}$  is given as

$$P_{Loss,k} = \{P_k^2 + (Q_k + Y_{k0}|V_k|^2)^2\} \frac{r_k}{|V_k|^2}$$

The reactive power flow equation is given as

$$Q_{k+1} = Q_k - Q_{Loss,k} - Q_{Lk+1} \quad (6)$$

where  $Q_{Loss,k}$  is given as

$$\begin{aligned} Q_{Loss,k} &= \{P_k^2 + (Q_k + Y_{k0}|V_k|^2)^2\} \frac{x_k}{|V_k|^2} \\ &\quad - Y_{k0}|V_k|^2 - Y_{k+1,0}|V_{k+1}|^2 \\ |V_{k+1}|^2 &= |V_k|^2 + \frac{r_k^2 + x_k^2}{|V_k|^2} \{P_k^2 + Q_k'^2\} \\ &\quad - 2\{r_k P_k + x_k Q_k\} \\ &= |V_k|^2 + \frac{r_k^2 + x_k^2}{|V_k|^2} \{P_k^2 + (Q_k + Y_{k0}|V_k|^2)^2\} \\ &\quad - 2\{r_k P_k + x_k (Q_k + Y_{k0}|V_k|^2)\} \end{aligned} \quad (7)$$

where  $P_k$  and  $Q_k$  are the real and reactive powers flowing out of bus  $k$ , and  $P_{Lk+1}$  and  $Q_{Lk+1}$  are real and reactive

load powers at bus  $k+1$ . The shunt admittance is denoted by  $Y_{k0}$  at bus  $k$  to ground. The resistance and reactance of line section between buses  $k$  and  $k+1$  are denoted by  $R_i$  and  $X_i$ , respectively.

The power loss of the line section connecting buses  $k$  and  $k+1$  may be computed as

$$P_{Loss}(k, k+1) = r_i \frac{(P_k^2 + Q_k'^2)}{|V_k|^2} \quad (8)$$

where  $r_i$  is resistance in the feeder  $i$ .

The total power loss in all feeders,  $P_{T,Loss}$  may then be determined by summing up the losses of all line sections of the feeder, which is given as

$$P_{T,Loss} = \sum_{i=0}^L P_{Loss}(k, k+1) \quad (9)$$

### III. HARMONY SEARCH ALGORITHM

The Harmony Search Algorithm (HSA) is a new meta-heuristic population search algorithm proposed by Geem, Kim, and Loganathan [22]. HSA was derived from the natural phenomena of musicians behavior when they collectively play their musical instruments (population members) to come up with a pleasing harmony (global optimal solution). This state is determined by an aesthetic standard (fitness function). The HS algorithm, is simple in concept, few in parameters, and easy in implementation, has been successfully applied to various benchmarking, and real-world problems like traveling salesman problem [23]. The main steps of HSA are as follows [22]:

- Step 1: Initialize the problem and algorithm parameters
- Step 2: Initialize the harmony memory
- Step 3: Improvise a new harmony
- Step 4: Update the harmony memory
- Step 5: Check the termination criterion

These steps are described in the next ve subsections.

#### A. Initialize the problem and algorithm parameters

The HS parameters are specified in this step. These are harmony memory size ( $HMS$ ), or number of solution vectors in the harmony memory; harmony memory considering rate ( $HMCR$ ); pitch adjusting rate ( $PAR$ ); and number of improvisations ( $NI$ ) or stopping criterion. The harmony memory ( $HM$ ) is a memory location where all solution vectors (sets of decision variables) are stored. The  $HM$  is similar to the genetic pool in the genetic algorithms ( $GA$ ). The parameters  $HMCR$  and  $PAR$  are used to improve the solution vector and these are defined in step 3.

#### B. Initialize the harmony memory

In this step, the  $HM$  matrix is filled with as many randomly generated solution vectors as the  $HMS$ :

$$HM = \begin{bmatrix} x_1^1 & x_2^1 & \dots & x_N^1 \\ x_1^2 & x_2^2 & \dots & x_N^2 \\ \vdots & \vdots & \vdots & \vdots \\ x_1^{HMS-1} & x_2^{HMS-1} & \dots & x_N^{HMS-1} \\ x_1^{HMS} & x_2^{HMS} & \dots & x_N^{HMS} \end{bmatrix} \quad (10)$$

### C. Improvise a new harmony

A New Harmony vector  $\vec{x}' = (x'_1, x'_2, \dots, x'_N)$  is generated based on three rules:

- Memory consideration
- Pitch adjustment
- Random selection

Generating a new harmony is called improvisation [22]. In memory consideration, the value of the first decision variable ( $x'_1$ ) for the new vector is chosen from any of the values in the specified HM range ( $x_1^1 - x_1^{HMS}$ ). Values of the other decision variables  $x'_2, x'_3, \dots, x'_N$  are chosen in the same manner. The *HMCR*, which varies between 0 and 1, is the rate of choosing one value from the historical values stored in the *HM*, while  $(1 - HMCR)$  is the rate of randomly selecting one value from the possible range of values, as shown in (11).

$$\begin{aligned} & \text{if}(\text{rand}() < HMCR) \\ & x'_i \leftarrow x'_i \in \{x_1^1, x_2^1, \dots, x_1^{HMS}\} \\ & \text{else} \\ & x'_i \leftarrow x'_i \in X_i \\ & \text{end} \end{aligned} \quad (11)$$

where  $\text{rand}()$  is a uniform random number between 0 and 1 and  $X_i$  is the set of the possible range of values for each decision variable, that is  $Lx_i \leq X_i \leq Ux_i$ .

For example, a *HMCR* of 0.85 indicates that the HSA will choose the decision variable value from historically stored values in the *HM* with an 85% probability or from the entire possible range with a (100-85)% probability. Every component obtained by the memory consideration is examined to determine whether it should be pitch adjusted. This operation uses the parameter, which is the rate of pitch adjustment as follows: For example, a *HMCR* of 0.85 indicates that the HSA will choose the decision variable value from historically stored values in the *HM* with an 85% probability or from the entire possible range with a (100-85)% probability. Every component obtained by the memory consideration is examined to determine whether it should be pitch adjusted. This operation uses the parameter, which is the rate of pitch adjustment as follows:

$$\begin{aligned} & \text{if}(\text{rand}() < PAR) \\ & x'_i = x'_i \pm \text{rand}() * bw \\ & \text{else} \\ & x'_i = x'_i \\ & \text{end} \end{aligned} \quad (12)$$

where  $bw$  is an arbitrary distance bandwidth.

### D. Update harmony memory

If the new harmony vector,  $\vec{x}' = (x'_1, x'_2, \dots, x'_N)$ , has better fitness function than the worst harmony in the *HM*, the new harmony is included in the *HM* and the existing worst harmony is excluded from the *HM*.

### E. Check stopping criterion

The HSA is terminated when the stopping criterion (e.g. maximum number of improvisations) has been met. Otherwise, steps 3 and 4 are repeated.

## IV. SOLUTION METHODOLOGY

The combined network reconfiguration and capacitor setting problem is a complex combinatorial optimization problem, getting the optimal solution using conventional methods is very difficult. In this paper, a nature inspired evolutionary algorithm, HSA, that mimics the improvisation process of music players is applied to minimize loss in the system.

The main idea, in this optimization process, is to get best combinations of open/closed switches of the given system and place an optimal size of capacitors at sensitive buses so that the combined network must give minimum real power loss and improve the voltage profile in the system.

In general, the structure of solution vector [2] for reconfiguration of a radial distribution system is expressed by *Arc No.(i)* and *SW No.(i)* for each switch  $i$ . *Arc No.(i)* identifies the arc (branch) number that contains the  $i$ th open switch, and *SW No.(i)* identifies the switch that is normally open on *Arc No.(i)*. For large distribution networks, it is not efficient to represent every arc in the string, since its length will be very long. In fact, the number of open switch positions is identical to keep the system radial once the topology of the distribution networks is fixed, even if the open switch positions are changed. Therefore, to memorize the radial configuration, it is enough to number only the open switch positions. Since the problem in hand is a combined optimization problem, the solution vector must contain the open switch numbers and capacitor setting values. Hence the first part of variables in the solution vector is open switch numbers and second part of variables is sizes of the capacitor settings. The second part of the solution vector is *kVAR* values required to be placed at different nodes in the system. If a network has  $n$  buses and  $s$  is number of available capacitor sizes, then there are  $(s + 1)^n$  possible combinations of solution are possible. This requires a lot of computational burden. In order to reduce the computational efficiency and dimension of the solution vector, voltage stability indices are used to select most sensitive nodes which require reactive power compensation. The procedure of computing voltage stability index is given in Appendix.

The format of the solution vector in Harmonic Memory (*HM*) matrix is

$$HMS = \begin{bmatrix} \underbrace{O_1 \dots O_n}_{\text{Tie Switches}} & \underbrace{kVAR_i \dots kVAR_m}_{\text{Capacitor sizes}} \end{bmatrix}$$

In order to explain the proposed method, a standard *IEEE* 33-bus distribution system is considered. It consists of 32 normally closed switches and 5 normally opened switches as shown in Fig. 2. This network contains one tie switch in each loop and these are designated as 33, 34, 35, 36, and 37. In the solution process only tie switches are used to form solution vectors of the *HMS*.

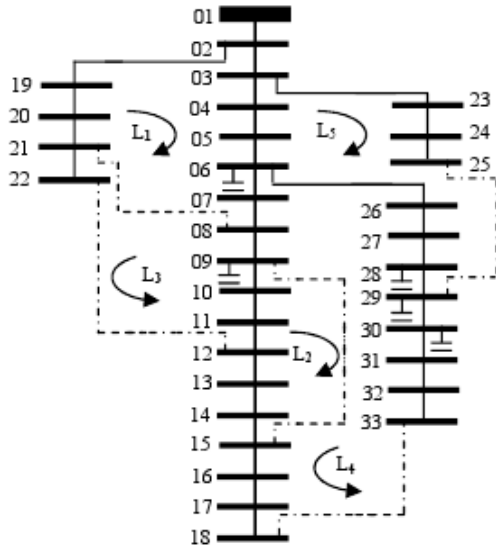

Fig. 2. Configuration of 33-bus system for solution vector 1 ( $HMS^1$ )

The computation of voltage stability indices help to select optimal locations (most sensitive nodes) for capacitor placement in the system. For this network optimal locations are computed as 6, 28, 29, 30 and 9 which require reactive power compensation to minimize power loss and improve voltage profile. Thus the second part contains three variables and these are capacitor *kVAR* ratings. Throughout the optimization process the dimension of second part of the solution vector is constant and only optimal size of the capacitor at a node will vary. The solution vector ( $HMS^1$ ) for this configuration is represented as:

$$HMS^1 = \left[ \underbrace{33 \ 34 \ 35 \ 36 \ 37}_{Reconfiguration} \ \underbrace{kVAR_i \ \dots \ kVAR_m}_{Capacitor \ Placement} \right]$$

The *kVAR* values are chosen randomly from 0 to maximum size of the capacitors available. For other solution vector ( $HMS^2$ ), a radial network, shown in Fig. 3, is randomly generated with open tie switches 19, 13, 21, 30, and 24 without violating the radiality constraint given in (3).

For this configuration the solution vector is represented as:

$$HMS^2 = \left[ \underbrace{19 \ 13 \ 21 \ 30 \ 37}_{Reconfiguration} \ \underbrace{kVAR_i \ \dots \ kVAR_m}_{Capacitor \ Placement} \right]$$

In the fashion, all the other possible solution vectors randomly are generated without violating the radial structure or

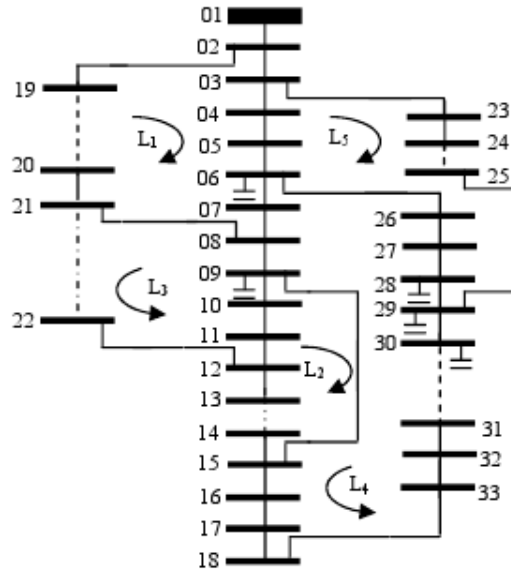

Fig. 3. Configuration of 33-bus system for solution vector 2 ( $HMS^2$ )

islanding any load in the network. For this network, total number of solution vectors generated are less than or equal to highest numbers of switches in any individual loop. The total Harmony Matrix (*HM*) generated randomly with objective function values is shown below.

$$\begin{bmatrix} 19 & 13 & 21 & 30 & 37 & kVAR_i & \dots & kVAR_m & | & f_1 \\ 6 & 34 & 14 & 30 & 37 & kVAR_j & \dots & kVAR_i & | & f_2 \\ \vdots & \vdots & \vdots & \vdots & \vdots & \vdots & \dots & \vdots & | & \vdots \\ 33 & 34 & 35 & 36 & 37 & kVAR_m & \dots & kVAR_j & | & f_n \end{bmatrix}$$

The objective function values ( $f_1, f_2, \dots, f_n$ ) shown in the last column of the *HM* matrix are sorted in ascending order to eliminate the worst solution vectors in the next iteration. The new solution vectors are updated by using (12). Using the new solution vectors, the worst vectors of previous iteration will be eliminated with a new random vectors selected from the population that has less objective function value. This procedure is repeated until termination criteria is satisfied. The flow chart of the proposed algorithm is shown in Fig. 4.

### V. TEST RESULTS

To demonstrate the application of the proposed method, three different test systems comprising of 33 and 16 buses are considered. In all the systems, the substation voltage is considered as 1 p.u. The algorithm was developed in MATLAB and simulations are carried using Pentium IV computer with 3.0 GHz, 1GB RAM.

#### A. Test System I

The first test system is a 33bus, 12.66 kV, radial distribution system [2] as shown in Fig. 2. It consists of five tie lines and 32 sectionalize switches. The normally open switches are 33

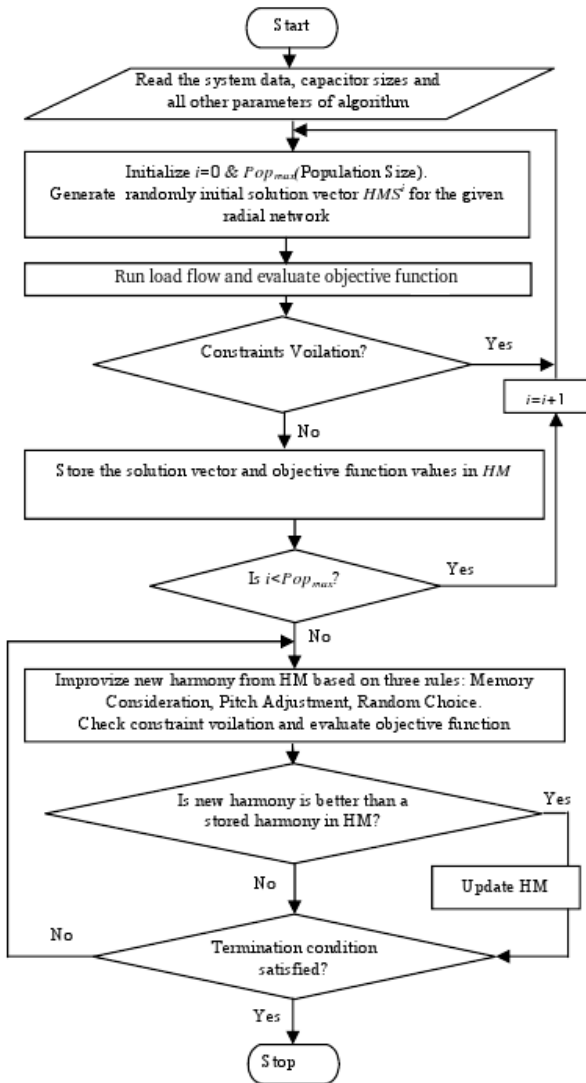

Fig. 4. Flow chart of the proposed algorithm

to 37 and the normally closed switches are 1 to 32. The line and load data of the network is obtained from reference [2] and the total real and reactive power loads on the system are 3715 kW and 2300 kVAR. The initial power loss of this system is 202.771 kW. The lowest bus bar voltage limit is 0.9131 p.u which occurs at node 18.

From computations of voltage stability index, most sensitive buses in the system are identified as {6, 28, 29, 30, 9} and capacitors banks are installed at these buses to improve the voltage profile. The sizing of Capacitors at candidate buses are done by using HSA along reconfiguration. The parameters HSA used in the simulation of the network is shown in Table I.

For the purpose analysis, we had investigated three cases using the proposed approach.

- Step 1: Only feeder reconfiguration
- Step 2: Only capacitor placement
- Step 3: Combining case 1 and 2 (Hybrid Approach)

TABLE I  
PARAMETER VALUES OF HARMONY SEARCH ALGORITHM

item	Value
HMS Size	15
Number of variables	10 [5 for reconfiguration + 5 for capacitor placement]
HMCR	0.9
Number of iterations	200

The final result of the proposed method is shown in Table II. Simulation results are also obtained by applying Simulated Annealing (SA) algorithm [19] in above three cases for comparison and are shown in Table III.

TABLE II  
FINAL RESULTS OF 33-BUS SYSTEM USING PROPOSED METHOD

item	Initial configuration	Final configuration		
		Case 1	Case 2	Case 3
Switch status	33, 34, 35, 36, 37	33, 14, 8, 32, 28	–	33, 14, 8, 32, 28
Capacitor installation (kVAR)	–	–	900 (6) 300 (28) 600 (29) 300 (30)	900 (6) 300 (28) 600 (29) 300 (30) 300 (9)
Total Power Loss (kW)	202.66	137.78	135.16	119.72
Power loss reduction (%)	–	32.02	33.33	40.93
Minimum Bus Voltage (pu)	0.9131	0.9301	0.9349	0.9411

### B. Test system II

This test system consists of three feeders, 13 sectionalizing switches, and three tie switches [19]. The load of the system is assumed to be constant and the system is taken from [19]. The sensitive buses of the system are computed as {4, 8, 13} and capacitors banks are installed at these buses to improve the voltage profile. The capacitor bank sizes and simulation parameters of HSA used in this test system is same as test case I. The size of the population is taken as 13. The simulation results of the system is shown in Table IV. Simulation results are also obtained by applying Simulated Annealing (SA) algorithm [19] in above three cases for comparison and are shown in Table Table V..

## VI. CONCLUSION

In the paper, a new hybrid approach using Harmony Search Algorithm (HSA) is proposed for real power loss reduction and voltage profile improvement in the distribution system. For comparison, the following three cases are considered and are applied on 33-bus and 3-feeder, 16-bus systems:

- Step 1: Only feeder reconfiguration
- Step 2: Only capacitor placement
- Step 3: Combining case 1 and 2 (Hybrid Approach)

From the results it has been observed that reduction in losses and improvement of voltage in the system can be achieved using either network reconfiguration (case 1) or

TABLE III  
COMPARISON OF RESULTS FOR 33-BUS SYSTEM

Item	Proposed Approach	Simulated Annealing (SA) [19]
Initial Switches Status	33,34,35, 36, 37	33,34,35, 36, 37
Minimum Bus Voltage (pu)	0.9131	0.9131
Power Loss for Base case	202.66	202.66
Case 1		
Final Configuration of switches	33, 14, 8, 32, 28	7, 14, 9, 32, 37
Power Loss (kW)	137.78	142.60
Loss reduction (%)	32.02	29.63
Minimum Bus Voltage (pu)	0.9301	0.9294
Case 2		
Capacitor installation (kVAR)	Bus 6=900 Bus 28=300 Bus 29=600 Bus 30=300	Bus 6=1050 Bus 28=450 Bus 29=300 Bus 30=300
Power Loss (kW)	135.16	136.11
Loss reduction (%)	33.33	32.84
Minimum Bus Voltage (pu)	0.9349	0.9301
Case 3		
Final Configuration of switches	33, 14, 8, 32, 28	7, 14, 9, 32, 37
Capacitor installation (kVAR)	Bus 6=900 Bus 28=300 Bus 29=600 Bus 30=300 Bus 9=300	Bus 6=1050 Bus 28=450 Bus 29=300 Bus 30=300 Bus 9=150
Power Loss (kW)	119.72	124.29
Loss reduction (%)	40.93	38.67
Minimum Bus Voltage (pu)	0.9411	0.9399

TABLE V  
COMPARISON OF RESULTS FOR 16-BUS SYSTEM

Item	Proposed Approach	Simulated Annealing (SA) [19]
Initial Switches Status	15, 21, 26	15, 21, 26
Minimum Bus Voltage (pu)	0.9693	0.9693
Power Loss for Base case	511.10	511.10
Case 1		
Final Configuration of switches	19, 17, 26	19, 17, 26
Power Loss (kW)	464.20	466.00
Loss reduction (%)	9.17	8.82
Minimum Bus Voltage (pu)	0.9731	0.9716
Case 2		
Capacitor installation (kVAR)	Bus 4=1950 Bus 8=1500	Bus 4=1800 Bus 8=1800
Power Loss (kW)	485.16	493.80
Loss reduction (%)	5.07	3.38
Minimum Bus Voltage (pu)	0.9718	0.9713
Case 3		
Final Configuration of switches	19, 17, 26	19, 17, 26
Capacitor installation (kVAR)	Bus 4=1950 Bus 8=1500 Bus 13=600	Bus 4=1800 Bus 8=1800 Bus 13=900
Power Loss (kW)	449.53	451.30
Loss reduction (%)	12.05	11.17
Minimum Bus Voltage (pu)	0.9760	0.9736

TABLE IV  
FINAL RESULTS OF 16-BUS SYSTEM USING PROPOSED METHOD

item	Initial configuration	Final configuration		
		Case 1	Case 2	Case 3
Switch status	15, 21, 26	19, 17, 26	-	19, 17, 26
Capacitor installation (kVAR)	-	-	1950 (4) 1500 (8)	1950 (4) 1500 (8) 600 (13)
Total Power Loss (kW)	511.10	464.20	485.16	449.53
Power loss reduction (%)	-	9.17	5.07	12.05
Minimum Bus Voltage (pu)	0.9693	0.9731	0.9718	0.9760

capacitor placement (case 2). However for case 3 the results are better than that of case 1 and 2 for both 33 and 16-bus systems. The results are also compared with the results obtained with Simulated Annealing algorithm. The proposed HSA method has outperformed the other method in terms of the quality of solution. Further it can be concluded that the type of method used loss reduction voltage profile improvement is highly depends on type of loads the system is feeding. For heavy active power loads the network reconfiguration and for heavy reactive power loads capacitor placement are suggested

methods for loss reduction and voltage profile improvement. But the Hybrid approach is applicable for any type of loading conditions.

APPENDIX A  
DERIVATION FOR VOLTAGE STABILITY INDEX

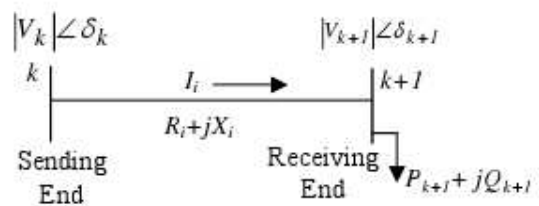

Fig. 5. Representative branch of radial distribution system

From Fig. 5.,

$$I_i = \frac{V_k - V_{k+1}}{R_i + jX_i} \tag{13}$$

$$P_{k+1} - jQ_{k+1} = V_{k+1}^* I_i \tag{14}$$

where

- $k, k + 1$  - Sending, Receiving end nodes of a branch
- $P_{k+1}$  - Total Real Power load fed through node  $k + 1$
- $Q_{k+1}$  - Total Reactive Power load fed through node  $k + 1$

$V_k, V_{k+1}$  - Voltage at node  $k$  and  $k + 1$

Using 13 and 14, Voltage stability index of node  $k + 1$  is written as

$$SI(k+1) = |V_k|^4 - 4\{P_{k+1}R_i + Q_{k+1}X_i\}|V_k|^2 - 4\{P_{k+1}X_i - Q_{k+1}R_i\}^2 \quad (15)$$

For stable operation of radial distribution system,  $SI(k+1) \geq 0$  for  $k+1 = 2, 3, \dots, n$ , so that there exists a feasible solution. Nodes with minimum voltage stability index, which are prone to voltage instability, in different laterals of radial distribution system are chosen as candidate locations for placement of capacitors.

#### REFERENCES

- [1] Bunch J.B., Miller R.D., and Wheeler J.E, "Distribution system integrated voltage and reactive power control," *IEEE Trans. PAS*, vol. 101, pp. 284-289, 1982.
- [2] M. E. Baran and F. F. Wu, "Network reconfiguration in distribution systems for loss reduction and load balancing," *IEEE Trans. Power Del.*, vol. 4, no. 2, pp. 1401-1407, Apr. 1989.
- [3] D. Shirmohammadi and H. W. Hong, "Reconfiguration of electric distribution networks for resistive line loss reduction," *IEEE Trans. Power Del.*, vol. 4, no. 2, pp. 1492-1498, Apr. 1989.
- [4] K. Nara, A. Shiose, M. Kitagawa, and T. Ishihara, "Implementation of genetic algorithm for distribution systems loss minimum reconfiguration," *IEEE Trans. Power Syst.*, vol. 7, no. 3, pp. 1044-1051, Aug. 1992.
- [5] G.J. Peponis, M.P. Papadopoulos, N.D. Hatziaargyriou, "Distribution network reconfiguration to minimize resistive line losses", *IEEE Trans. Power Deliv.*, vol. 10, pp. 1338-1342, 1995.
- [6] N.C. Sahoo, K. Prasad "A fuzzy genetic approach for network reconfiguration to enhance voltage stability in radial distribution systems" *Energy Conversion and Management*, vol. 47 pp. 3288-3306, 2006.
- [7] E. Carpaneto, G. Chicco, "Distribution system minimum loss reconfiguration in the Hyper-Cube Ant Colony Optimization framework", *Electric Power Systems Research*, vol. 78, no. 12, pp. 2037-2045, Dec. 2008.
- [8] R. Srinivasa Rao, S. V. L. Narasimham, "A New Heuristic Approach for Optimal Network Reconfiguration in Distribution Systems", *International Journal Applied Science, Engineering and Technology*, vol. 5, no. 1, pp. 15-21, 2009.
- [9] A.Y. Abdelaziz, F.M. Mohammed, S.F. Mekhamer, M.A.L. Badr, "Distribution Systems Reconfiguration using a modified particle swarm optimization algorithm", *Electric Power Systems Research*, vol 79, no. 11, pp. 1521-1530, November 2009.
- [10] J. J. Grainger and S. H. Lee, "Optimum Size and Location of Shunt Capacitors for Reduction of Losses on Distribution Feeders," *IEEE Trans. on Power Apparatus and Systems*, Vol. 100, No. 3, pp. 1105-1118, March 1981.
- [11] M. E Baran and F. F. Wu, "Optimal Sizing of Capacitors Placed on a Radial Distribution System", *IEEE Trans. Power Delivery*, vol. No.1, pp. 1105-1117, Jan. 1989.
- [12] Ng et al, "Capacitor Allocation by Approximate Reasoning: Fuzzy Capacitor Placement," *IEEE Trans. Power Delivery*, Vol. 15, No.1, pp. 393-398, Jan. 2000.
- [13] D. Das, "Reactive power compensation for radial distribution networks using genetic algorithms," *Electric Power and Energy Systems*, vol. 24, pp.573-581, 2002.
- [14] Ji-Pyng Chiou, Chung-Fu Chang, and Ching-Tzong Su, "Ant Direction Hybrid Differential Evolution for Solving Large Capacitor Placement Problems", *IEEE Transactions on Power Systems*, Vol. 19, No. 4, pp. 1794-1800, Nov. 2004
- [15] Ji-Pyng Chiou et al, "Capacitor placement in large scale distribution system using variable scaling hybrid differential evolution," *Electric Power and Energy Systems*, vol. 28, pp.739-745, 2006.
- [16] Chung-Fu Chang et al, "Robust searching hybrid differential evolution method for optimal reactive power planning in large-scale distribution systems", *Electric Power Systems Research*, vol. 77, pp.430-437, 2007.
- [17] D. Jiang and R. Baldick, "Optimal electric distribution system switch reconfiguration and capacitor control," *IEEE Trans. Power Syst.*, vol. 11, no. 2, pp. 890-897, May 1996.
- [18] R. Srinivasa Rao and S.V.L. Narasimham, "Optimal Capacitor Placement in a Radial Distribution System using Plant Growth Simulation Algorithm", *International Journal of Electrical Power and Energy Systems Engineering*, Vol. 1, No.2, pp. 123-130, 2008.
- [19] C. T. Su and C. S. Lee, "Feeder reconfiguration and capacitor setting for loss reduction of distribution systems," *Elect. Power Syst. Res.*, vol. 58, no. 2, pp. 97-102, Jun. 2001.
- [20] Z. Rong, P. Xiyuan, and H. Jinliang, "Reconfiguration and capacitor placement for loss reduction of distribution system," *Proc. IEEE International Conference, TENCON'02*, 2002, pp. 1945-1949.
- [21] Dong Zong, Z. Fu, L. Zhang, "Joint optimization for loss reduction of distribution system," *IEEE Trans. Power Syst.*, vol. 23, no. 1, pp. 161-169, February 2008.
- [22] Z. W. Geem, J. H. Kim, and G. V. Loganathan, "A new heuristic optimization algorithm: harmony search", *Simulation*, vol. 76, no. 2, pp. 6068, 2001.
- [23] Z.W. Geem, C. Tseng, and Y. Park, "Harmony search for generalized orienteering problem: best touring in China", *Springer Lecture Notes Comput. Sci.*, 3412 (2005) 741750.
- [24] K.S. Lee, and Z.W. Geem, "A new meta-heuristic algorithm for continues engineering optimization: harmony search theory and practice," *Comput. Methods Appl. Mech. Engg.*, vol. 194 pp. 3902-3933, 2004.

**R. Srinivasa Rao** received the B.Tech degree in electrical engineering from SVU Tirupathi (INDIA) in 1996, the M.E degree from IISc Bangalore in 1998, and the Ph.D. degree from JNTU in 2009. Currently, he is Associate Professor in department of electrical engineering, JNTU Kakinada, INDIA. His areas of interest include electric power distribution systems and power systems operation and control.