

An Evaluation Method for Two-Dimensional Position Errors and Assembly Errors of a Rotational Table on a 4 Axis Machine Tool

Jooho Hwang, Chang-Kyu Song, and Chun-Hong Park

Abstract—This paper describes a method to measure and compensate a 4 axes ultra-precision machine tool that generates micro patterns on the large surfaces. The grooving machine is usually used for making a micro mold for many electrical parts such as a light guide plate for LCD and fuel cells. The ultra precision machine tool has three linear axes and one rotational table. Shaping is usually used to generate micro patterns. In the case of 50 μm pitch and 25 μm height pyramid pattern machining with a 90° wedge angle bite, one of linear axis is used for long stroke motion for high cutting speed and other linear axis are used for feeding. The triangular patterns can be generated with many times of long stroke of one axis. Then 90° rotation of work piece is needed to make pyramid patterns with superposition of machined two triangular patterns.

To make a two dimensional positioning error, straightness of two axes in out of plane, squareness between the each axis are important. Positioning errors, straightness and squareness were measured by laser interferometer system. Those were compensated and confirmed by ISO230-6. One of difficult problem to measure the error motions is squareness or parallelism of axis between the rotational table and linear axis. It was investigated by simultaneous moving of rotary table and XY axes. This compensation method is introduced in this paper.

Keywords—Ultra-precision machine tool, multi-axis errors, squareness, positioning errors.

I. INTRODUCTION

WHEN a material is removed by machining, it is difficult to generate sub-micron or micron level fine patterns from mechanical micromachining due to technical limitations in manufacturing micromachining tools. But, micromachining can deal with a variety of materials and make complex shapes with relatively fast speeds compared to other manufacturing methods. The markets for display related products such as light guide panels have been rapidly growing and they give an impulse to more technology development in how to make micro or sub micro features on large surfaces. Here we use large surfaces as a relative term, in which the feature size is quite small compared to the overall workpiece size, e.g. 10 microns features generated on a 400×400 mm² (22 inches in diagonal)

Jooho Hwang is with Korea Institute of Machinery and Materials, Daejeon, 305-343 S. Korea (corresponding author phone: +82-42-868-7119; fax: +82-42-868-7180; e-mail: jooho@kimm.re.kr).

Chang-Kyu Song is with Korea Institute of Machinery and Materials, Daejeon, 305-343 S. Korea (e-mail: song@kimm.re.kr).

Chun-Hong Park is with Korea Institute of Machinery and Materials, Daejeon, 305-343 S. Korea (e-mail: pch657@kimm.re.kr).

metal plate. The market demands also drive development of many machine tools for micromachining on large surfaces. Many lathe-type ultra precision micromachining machines have been recently introduced in the market, but as the market trends go beyond 10~12 inches panels and the corresponding mold and machine sizes are getting bigger, milling-type ultra precision machines becomes more popular than the lathe-type machines.[1-3]

In this paper, an evaluation and compensation method for a two dimensional positioning error, straightness of two axes in out of plane, squareness between the each axis are important. Positioning errors, straightness and squareness were measured by laser interferometer system. Those were compensated and confirmed by ISO230-6. One of difficult problem to measure the error motions is squareness or parallelism of axis between the rotational table and linear axis. It was investigated by simultaneous moving of rotary table and XY axes.

II. CONFIGURATIONS OF THE MACHINE TOOL

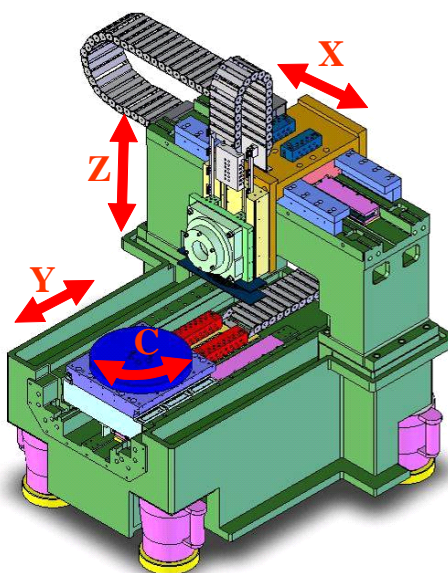

Fig. 1 Configuration of the 4 axis ultra precision machine

Fig. 1 shows the basic configurations of the ultra-precision 4 axis machine tools. It has 3 linear axes and 1 rotational axis to be used in shaping, milling and turning process. The

hydrostatic oil bearings are used for the guide of all the 4 axes, regarding compactness and high stiffness of the machine tools. To maintain non-contact state, the coreless linear motors are used for actuators of 3 linear axes and a frameless rotating motor is inserted in a rotating table.

The machining volume of the machine tool is 500 mm × 500 mm × 150 mm and the rotating axis (c-axis) is inserted in Y axis. The base of the machine tools is made from cast iron and supported by four air-springs vibration mount. The vertically moving axis (Z-axis) weighs 70.8 kg and wiring with an another 70.8 kg counter mass and mounted on the X axis. The position sensor of the each linear axes is a hologram precise optical scales, which has 650 μm precise grating and the resolution is changeable from 300 nm to 1 nm.

III. EVALUATION AND COMPENSATION OF THE LINEAR AXES

The error of the z axis; small moving axis; is relatively smaller than X and Y axes, because the machine tool is used for generating micro patterns. Therefore, the 2-dimensional position errors are main errors to be compensated. The two dimensional (2D) errors are occurred owing to relative motion of the two axes. The 2D position errors on the XY plane are mainly affected by straightness, pitch, yaw and perpendicular errors of the each axis. In the case of machining micro patterns on the plane, the change of height along to Z axis is less than 100 μm and effect of yaw error can be simplified by assuming tool point is on the center. Therefore, the measured 1D position error can replace the errors owing to yaw and pitch errors and can be expressed by:

$$\begin{bmatrix} \delta P_x(i, j) \\ \delta P_y(i, j) \end{bmatrix} = \begin{bmatrix} \delta P_{x1D}(i) + \delta_x(j) \\ \delta P_{y1D}(j) + a_x(i)\theta_{xy} + \delta_y(i) \end{bmatrix} \quad (1)$$

Where, $\delta p_x(i,j)$ and $\delta p_y(i,j)$ are x direction and y direction errors according to position of x and y, respectively; $\delta p_{x1D}(i)$ is 1D position of X axis and ; $\delta_x(j)$ and $\delta_y(j)$ represent horizontal

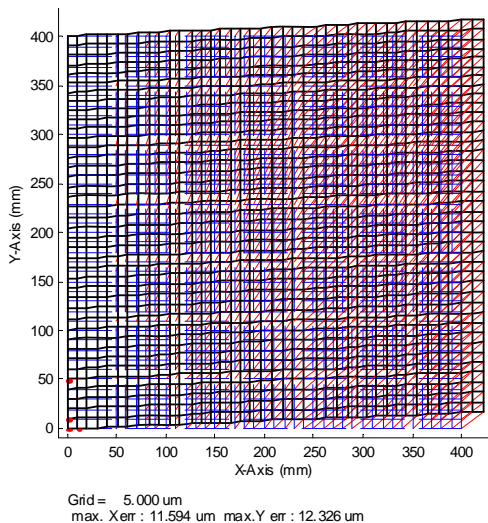

Fig. 2 Estimated 2D position errors on the XY plane

motion errors at machining point in the X and Y directions; θ_{xy} is perpendicular error between X and Y and a_x is moving distance from origin of X axis.

The position and motion errors in equation (1) was measured by laser interferometer and used as inputs. Fig. 2 shows the estimated 2D position errors. The maximum deviations of 2D position errors are 11.59 μm for x-axis and 12.33 μm for y-axis, respectively. The estimated position errors are compared with diagonal measurement shown in Fig. 3. As shown in the Fig. 3 a steering mirror is located in front of the beam splitter and it turns angle of beams to 45° and the reflector is fixed on the corner of the tables. The height of the beam path is maintained at 120 mm, which is average height of the machining point. The measured results are analyzed by ISO 230-6 standard and shown in Fig. 4. The estimated error laser interferometer measured data along two diagonals, (400,400) to (0,0) and (0,400) to (400,0) are compared with in the Fig. 4. As shown in the figure the estimated errors are similar in shape and magnitude. It shows that the error model of the equation (1) is efficient to estimate 2D models.

The 1D position error was measured in center of the table and compensated each X and Y axis. The perpendicular error (θ_{12}) affects the position error $\delta p_y(i,j)$ as indicated by equation (1). It is possible to measure the perpendicular error using two



Fig. 3 Diagonal measurement in the XY plane

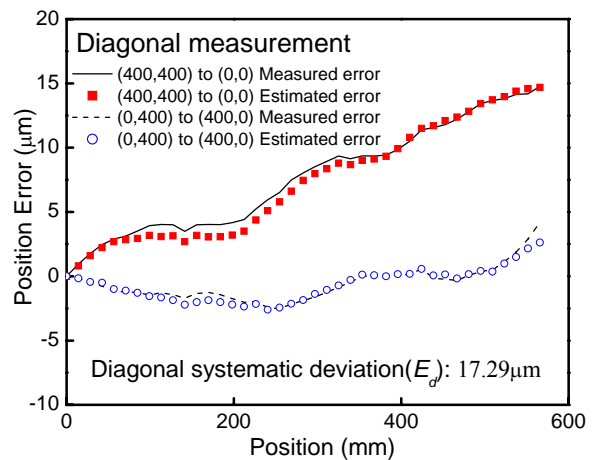

Fig. 4 Diagonal measurement results before compensation

different methods. The easier one is calculating the error directly from the diagonal measurements using equation (2),

$$\theta_{12} = \cos^{-1} \frac{P_d^2 - P_x^2 - P_y^2}{2P_x P_y} \quad (2)$$

where P_d is the measured position along the diagonal direction, P_x is the measured position along the X-axis, and P_y is the measured position along the Y-axis. This is easy to measure and requires only one step of the diagonal measurement process without changing the interferometer system optics.

To compensate 2D errors in XY plane, each errors were corrected by re-shaped command signal. The horizontal motion error was eliminated by small shift of the cross-axis.

Fig. 5 shows the estimated 2D position errors when all the errors describing in equation (1) are compensated. The estimated maximum errors are $0.12 \mu\text{m}$ and $0.71 \mu\text{m}$ in X-axis and Y-axis, respectively.

The diagonal measurement errors are shown in Fig. 6. As shown in figure, the diagonal systematic errors are decreased from $17.3 \mu\text{m}$ to $1.44 \mu\text{m}$ from the effect of compensation. The comparison between estimated and measured errors are shown

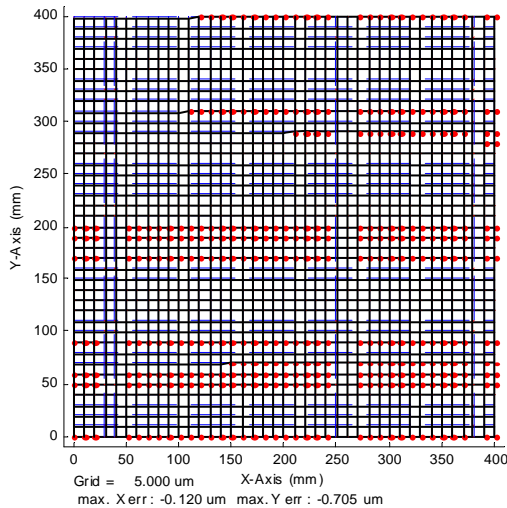

Fig. 5 Estimated 2D position errors after compensation

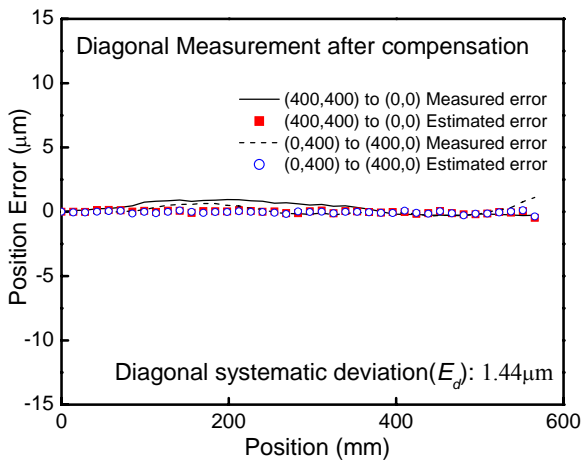

Fig. 6 Diagonal measurement results after compensation

in Fig. 6. The motion errors, those are used as input of the estimation, were measured in center position of the table but, the diagonal errors were measured in the corner of the table as shown in Fig. 3. Those could be the main reason of difference between the estimated and measured data. The amount and shapes of difference shown in both Figs. 4 and 6 are very similar.

IV. ERRORS OF THE ROTATIONAL AXIS

One of main application of the micro patterns on the large surface is making pyramid patterns. To make the pyramid, the triangular prism pattern is grooved firstly along X axis then patterned material is rotated 90° by C axis and same triangular prism is grooved cross of the previous pattern.

During 90° rotating, the height change in the surface is occurred owing to perpendicular errors between C, X and Y axis.

To measure the angle between linear and rotational table, circular interpolation was simultaneously moved in X and Y axis with rotational table. Which made the measuring target pointing is always same, as shown in Fig. 8. From the motion the profiles error of the artifact on the C-axis could be eliminated.

The solid line in Fig. 9(a) is measured data of the deviation of the height ($h(\theta)$), which is main error source of the motion of the tables. To divide the error sources of the tables, tilt motion error of the rotary table, which is shown in dashed line of Fig. 9(a), was eliminated and the result is shown in solid line of (b), which is supposed to be perpendicular errors of the X and Y axis. And, Perpendicular errors are estimated as dashed line of (b). After eliminating the perpendicular errors, remained errors are supposed to be superposed errors of X and Y tables motion errors, which is shown in (c).

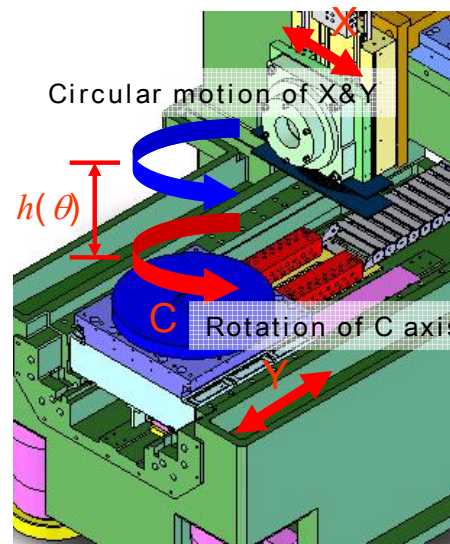

Fig. 7 Measuring perpendicular errors between C and X-Y axis

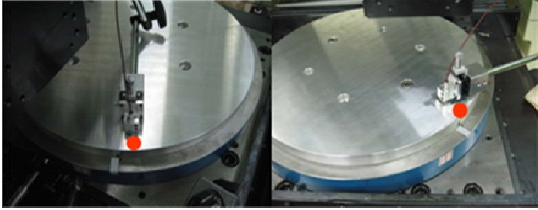

Fig. 8 Simultaneous three axis motion

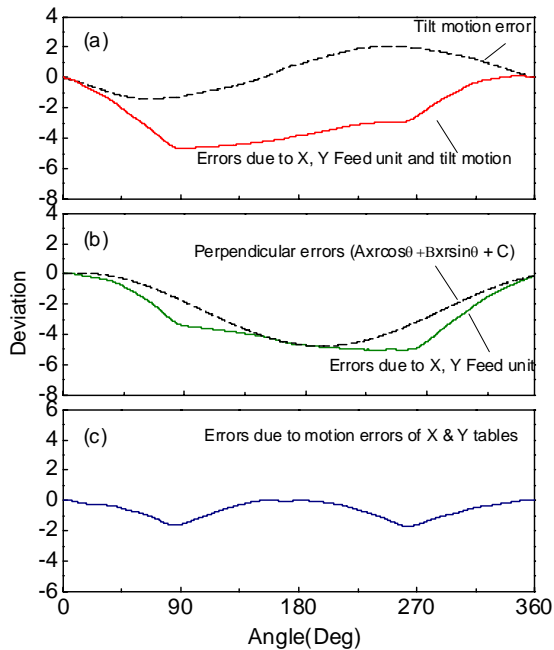

Fig. 9 Analysis of the Errors between rotational table and linear tables

V. CONCLUSION

This paper describes a method to measure and compensate a 4 axes ultra-precision machine tool that generates micro patterns on the large surfaces. To compensate a two dimensional positioning error, straightness of two axes in out of plane, squareness between the each axis are important. Positioning errors, straightness and squariness were measured by laser interferometer system. One of difficult problem to measure the error motions is squareness or parallelism of axis between the rotational table and linear axis. It was investigated by suggested simultaneous motion of the three axes.

REFERENCES

- [1] Y. Takeuchi, H. Yonekura and K Sawada, "Creation of 3-D tiny statue by 5-axis control ultraprecision machining," *Computer-Aided Design*, Vol. 35, No. 4, pp. 403-409, 2003.
- [2] S. Gan, H. Lim, M. Rahman and W. Frank "A fine tool servo system for global position error compensation for a miniature ultra-precision lathe," *International Journal of Machine Tools & Manufacture*, Vol. 47, No. 7-8, pp. 1302-1310, 2007.
- [3] Bono, M. and Hibbard, R., "A flexure-based tool holder for sub- μm positioning of a single point cutting tool on a four-axis lathe," *Precision Engineering*, Vol. 31, No. 2, pp. 169-176, 2007.
- [4] A.C. Okafor, Y.M. Ertekin, Derivation of machine tool error models and error compensation procedure for three axes vertical machining.

- International Journal of Machine Tools and Manufacture. 2000; 40; 1199-1213.
- [5] C. Raksiri, M. Parnichkun, Geometric and force errors compensation in a 3-axis CNC milling machine, *International Journal of Machine Tools and Manufacture*. 2005; 44; 1283-1291.
- [6] A.H. Slocum, *Precision Machine Design*, Prentice Hall, Englewood Cliffs, NJ, 1992.
- [7] ISO230-6, Test Code for Machine Tools-Part 6: Determination of Positioning Accuracy on Body and Face Diagonals (Diagonal Displacement Tests) 2002.
- [8] M.A.V. Chapman, Limitations of laser diagonal measurements, *Precision Engineering*; 2003; 27; 401-406.
- [9] J. Hwang, C.H. Park, C.H. Lee and S.W. Kim, "Estimation and correction method for the two-dimensional position errors of a planar XY stage based on motion error measurements," *International Journal of Machine Tools and Manufacture*, 46, pp. 801-810, 2006.