

# An Empirical Dynamic Fuel Cell Model Used for Power System Verification in Aerospace

Giuliano Raimondo, Jörg Wangemann, Peer Drechsel

**Abstract**—In systems development involving Fuel Cells generators, it is important to have from an early stage of the project a dynamic model for the electrical behavior of the stack to be shared between involved development parties. It allows independent and early design and tests of fuel cell related power electronic. This paper presents an empirical Fuel Cell system model derived from characterization tests on a real system. Moreover, it is illustrated how the obtained model is used to build and validate a real-time Fuel Cell system emulator which is used for aerospace electrical integration testing activities.

**Keywords**—Fuel cell dynamics, real time simulation, fuel cell, modelling, testing.

## I. INTRODUCTION

**E**CO-EFFICIENCY has become an important technology driver for new aircraft designs in civil aviation industry. This is enforced by economical means as the scarcity of oil reserves and political means such as taxes on pollution. For these reasons, the aviation industry has defined ambitious targets in ACARE 2020 [1] and Flight Path 2050 [2], in particular the reduction of CO<sub>2</sub> by 50% respectively 75% for future aircraft designs compared to aircraft of the year 2000.

Fuel cells are regarded to be an important technology brick to achieve these targets [3]. They provide electrical power with an efficiency of above 50% without causing any local pollution or noise. Airbus pushes their integration to new aircraft models within several research and technology projects [4]-[16]. The range of applications is from emergency systems [5], [10] and fire protection systems [11] applicable for legacy aircraft, through Multifunctional Fuel Cell Systems [4], [6], [7], [12], [13], [15] for future More Electric aircraft to even more ambitious fuel cell based aircraft propulsion systems [8]. The Airbus Integrated Fuel Cell Technology team, based in Hamburg (Germany), identifies those aircraft applications and develops appropriate system architectures. In many cases, the generated electrical power is distributed through the electrical aircraft network. The power networks team, based in Toulouse (France), is in charge of the design of the aircraft network and has to verify the proper operation of power generating and consuming systems in the network using appropriate testing facilities [17]. Airbus Group Innovations provides advice and upstream key technology bricks, particularly power converter knowledge and hardware [9], [10], [16] and is based in Munich and Hamburg. The German

Aerospace Center (DLR) provides support on key fuel cell technology [13], [14] and local lab operations and is based in Stuttgart and Hamburg.

The distribution of the project team and the lab facilities across different places in Europe requires adequate methods of cooperation through all phases of the design process. Depending on the technical question, the power converter is operated either at its place of creation in Munich or is integrated with the fuel cell system in Hamburg or with the electrical network in Toulouse. Rather than written requirements and specification documents, each subsystem design team needs a meaningful physical representation of its respective electrical interface to investigate the interactions and operation scenarios between the subsystems, especially for transient conditions. So, the fuel cell systems team needs a link to the electrical aircraft network, the electrical networks team needs a link to the fuel cell system, and the power converter design team needs both links. The scope of this paper takes focus on creating the link to the electrical network by developing a representation of the electrical characteristics of the fuel cell system, particularly its dynamic characteristics. These are investigated during a test campaign in Hamburg. The test configuration and key findings are described in the following section II. The results are used to derive a dynamic real time simulation model of the electrical characteristics of the fuel cell system. This constitutes the link between the design teams. A detailed description of the model and all submodels and its assumption are provided in section III. This model is then implemented by the power networks team to a programmable lab power system in Toulouse as illustrated in section IV. This approach enables all design teams to achieve a deeper understanding of the others technology at an early stage of the project and will likely result in better future designs, since modifications and improvements can be formulated in the model rather than in written words and diagrams. This follows a Model Based System Engineering approach of virtual design & executable specification.

These activities are supported by the German funding projects LuFo and BeZel.

## II. FUEL CELL POWER SYSTEM TESTING

The test setup consists of fuel cell stacks supplied by hydrogen in recirculation loop configuration and a compressor powered air supply. The compressor command is generated by the fuel cell system controller to operate the stack in appropriate conditions. Meanwhile, the set point of the hydrogen recirculation loop remains constant. A DC/DC converter [16] generates a DC grid which is exposed to

Giuliano Raimondo, Jörg Wangemann, and Peer Drechsel are with the AIRBUS, France (e-mail: giuliano.raimondo@airbus.com; joerg.wangemann@airbus.com; peer.drechsel@airbus.com).

constant and transient step loads that are exerted by a controllable electronic load. Fig. 1 shows a simplified block diagram of the test configuration. There is one limitation of the test setup: The rated current of the DC/DC converter is only ~30% of the rated current of the FC stack. In order to investigate the behavior of the stack in its whole operating regime, an additional static electric load is connected in parallel to the DC/DC converter (not shown).

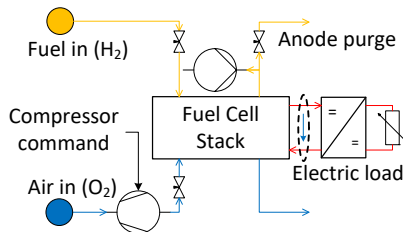
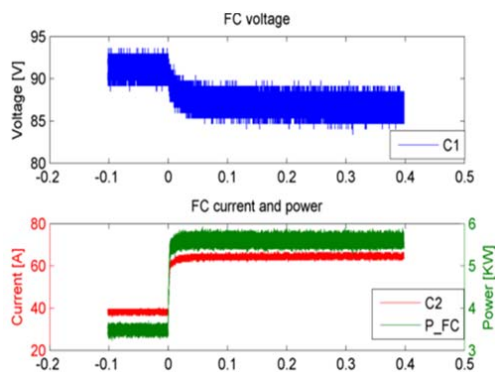
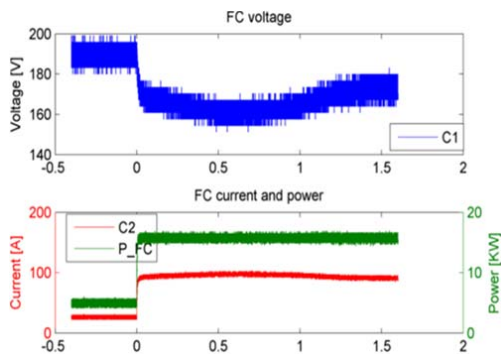

Fig. 1 Simplified test configuration with fuel cell stack with compressor powered air supply and electric load

From the perspective of the fuel cell stack, neither the actual type of power converter nor the type of grid that it supplies (e.g. DC or balanced AC) is relevant for most cases. The crucial fact is that all loads/transients appear as constant power loads with negative impedance characteristics to the stack, i.e. a voltage drop results in an immediate increase of the current, while the power is constant. This is the common case in grid supply applications the FC system must comply with.



(a)



(b)

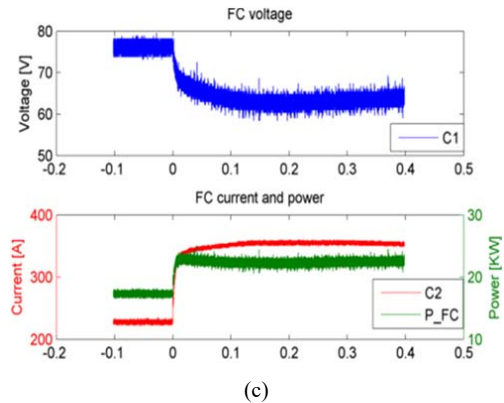

(c)

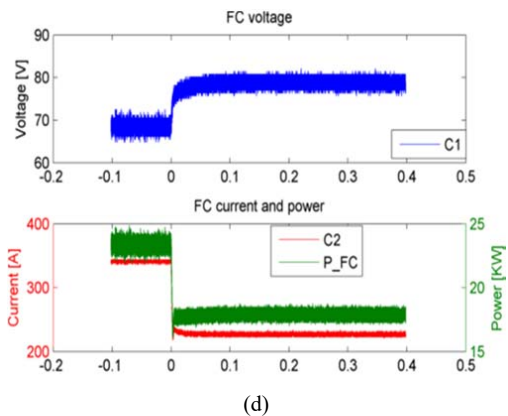

(d)

Fig. 2 FC dynamic test results: a) Small load step from small to medium load. b) Medium load step from small to medium load. c) Big load step from high to full load. d) Big load release from full to high load

In the test campaign, step load and release transients of several magnitudes are applied to the grid. Since the nature of fuel cell systems is highly nonlinear, the actual electrical load and the operating point right before the transient are relevant. Fig. 2 shows the electrical load step responses of the stack voltage and current of some representative test results.

The voltage and current are measured at the terminals of the FC stack as indicated in Fig. 1. The actual power is calculated from the stack current and voltage. In all cases, this FC stack is capable to draw the required power right after the transition up to a magnitude of ~30% of rated power. However, this limitation was due to the rated current of the DC/DC converter and not the FC stack. At small load steps, as shown in Fig. 2 (a), the voltage transitions smoothly to the new point of operation.

Fig. 2 (b) shows the same test with increased step magnitude. Apparently, the voltage continues to drop for 0.6 s until it recovers and settles at 1.2 s. This is roughly the time that it takes to speed up the air compressor to the new point of operation. In Fig. 2 (c), the load step is applied from ~70% rated power. Interestingly, the intermittent voltage drop is much smaller than in Fig. 2 (b). Since, the H<sub>2</sub> recirculation loop is in constant operation in all cases, the effect is apparently matter of the characteristics of the volume inside

the flow field and the air/ O<sub>2</sub> supply system: Without adjusting the air mass flow, a load transient of a certain magnitude, results in a reduction of oxygen concentration (stoichiometry) inside the flow field. Since the current relates directly to the oxygen consumption, the change of concentration is higher when the transient occurs, while the stack is operated at small

loads. Additionally, the mass flow through the flow field and hence the exchange rate of air inside the cathode volume is higher at operation at high loads.

Fig. 2 (d) shows the results of a load release transient. The FC stack response does not show any voltage overshoot.

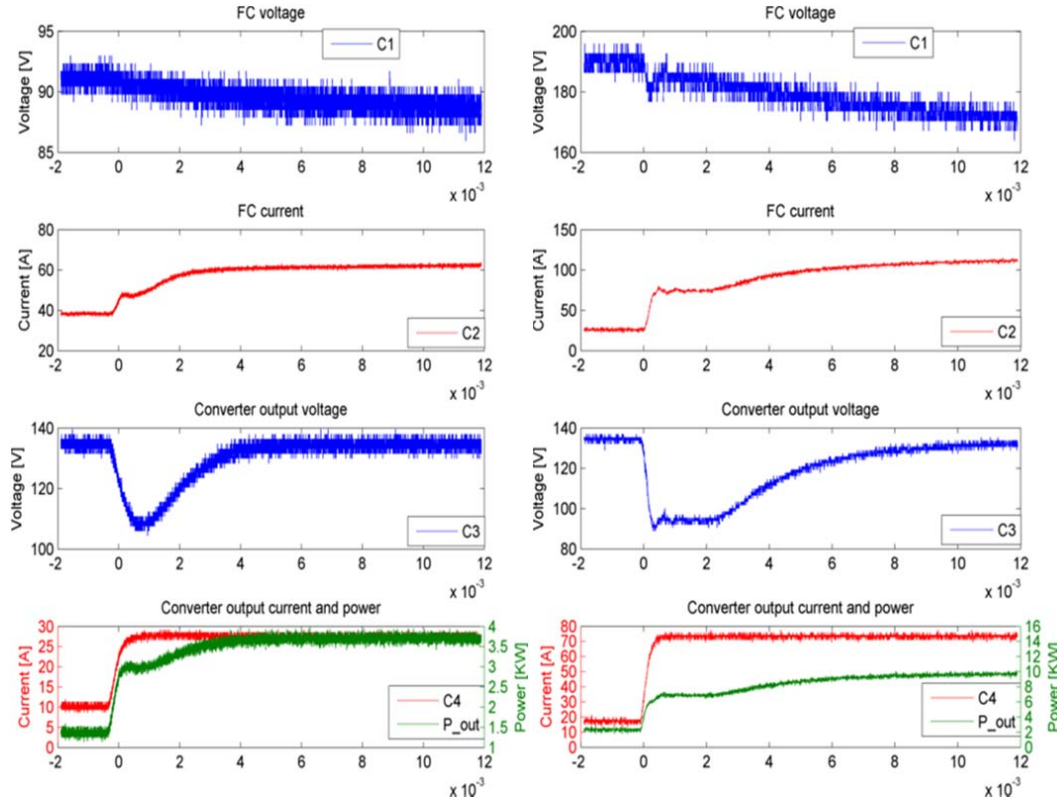

Fig. 3 Magnified view of the transition of the test results from Figs. 2 (a) and (b)

The time scaled view of the tests in Figs. 2 (a) and (b) is shown in Fig. 3. The DC/DC converter draws the amount of power that is required to maintain the voltage at the supplied DC grid. The transients at the grid propagate to the FC stack in a few hundred microseconds because the filters are really small. The full transient power appears within 8 ms when the control loops are back in steady state. In both cases, the FC stack shows almost capacitive behavior. It is capable to supply the transients immediately and does not suffer relevant voltage breakdown within the first milliseconds after the transient.

These observations are used to create a “useful” real-time model to qualitatively represent the relevant electrical dynamic characteristics of the FC stack and air supply system.

### III. FUEL CELL SYSTEM MODEL

The purpose of the model is to represent the relevant electrical dynamic characteristics that have been observed in the test campaign rather than being physically correct, while considering the principles described in [18]. Particularly, the effects of air/oxygen supply system behavior and the stored volume inside the stack appear to be relevant. The model is

parameterized to represent the dynamics of a fuel cell stack that is operated with a compressor powered air supply. The number of cells is set to the number which is expected for the emergency power supply system.

Fig. 4 illustrates the operation of a single fuel cell. The anode and the cathode are supplied with hydrogen and air. The mass flow rate of air and the concentration of oxygen is identified by  $\dot{m}$  and  $Y_{O_2}$ . The oxygen concentration inside the flow field depends on the actual electric load and the air mass flow. In Fig. 4 (a), the whole volume inside the flow field of one single cell is assumed to be a homogenous mixture with one oxygen concentration (and temperature and pressure). In a more realistic representation, the oxygen concentration is the highest at the air inlet and decreases on the way to the outlet while oxygen is consumed as illustrated in Fig. 4 (b). In some cases, all oxygen may be consumed at the outlet. This condition is called (partial) oxygen starvation [19] and is matter to high magnitude load transients.

The fuel cell system model is based on these assumptions. All components are described in the following sections.

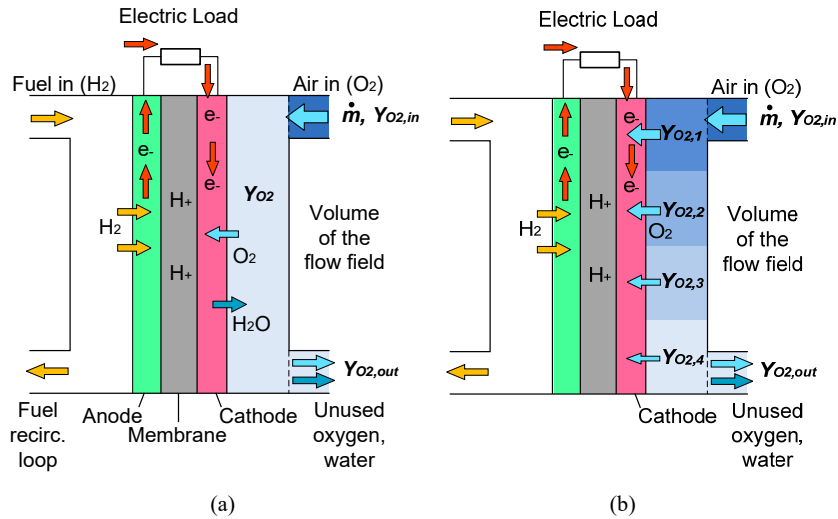

Fig. 4 PEM fuel cell and with cathode volume and discretized volume elements

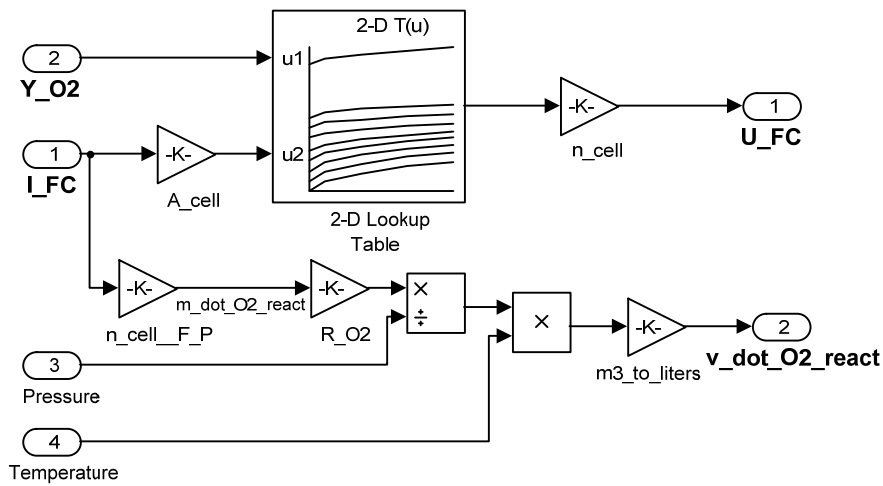

Fig. 5 Cathode and membrane model with polarization table and Nernst-equation

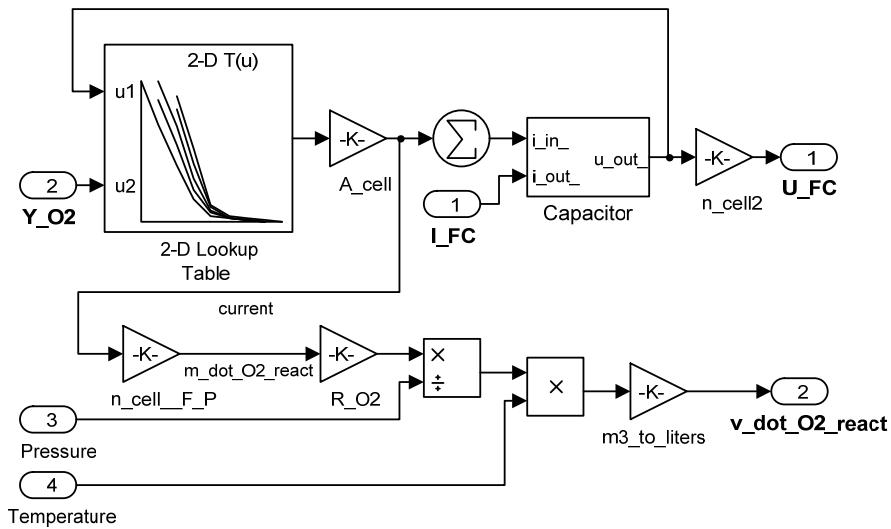

Fig. 6 Cathode and membrane model with polarization table, electrical capacitance and Nernst-equation

### A. Cathode and Membrane

The simplest implementation of a fuel cell cathode and membrane submodel is shown in the block diagram in Fig. 5. It consists of a static lookup table providing the cell voltage while the cell current and the actual oxygen concentration inside the cathode volume is known. The actual oxygen consumption is determined using the Nernst equation.

It is  $U_{FC}$  and  $I_{FC}$  the actual FC stack voltage and current. The oxygen consumption is calculated by Nernst-equation and is identified by  $v_{dot\_O2\_react}$ . Furthermore, the pressure and temperature inside a cathode volume element can be provided by another submodel or constant.

The model in Fig. 6 takes into account the capacitive behavior of the FC. Since the output of the capacitor model is the cell voltage and the input is the cell current, the lookup table is transformed to provide a current output and a voltage input. Hence, the polarization table is featuring swapped parameters ( $I$  vs  $U$  instead  $U$  vs  $I$ ).

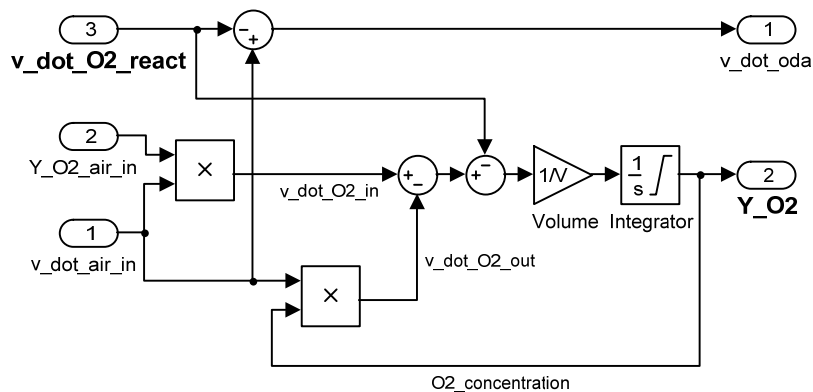

Fig. 7 Volume element of an air-supplied cathode providing the oxygen concentration at a certain consumption and flow rate

The submodel of such a volume element is illustrated in Fig. 7.

### C. Flow Controller and Compressor or Servo Valve

The actual electrical dynamic characteristics depending on the configuration of the media supply system. In the test campaign, this has been an air compressor to provide the required air flow rate to achieve the desired condition of the oxygen depleted air (ODA). The air flow is controlled by variation of the motor speed. The FC system model is parameterized to approximate the system behavior during the test campaign. Apparently, the electrical dynamics of the FC stack strongly depend on the air supply system. Much faster response can be achieved if compressed air is available, and the air supply is controlled by a servo valve.

### D. Fuel Cell System

Fig. 8 illustrates the simplest implementation of a fuel cell system considering the cathode air supply dynamics. An Electrical\_Load is connected to the fuel cell stack. It is

The submodel can be discretized to the desired number of elements by simply connecting vectors of the respective size, with each element being operated with its own oxygen concentration, temperature and pressure. From the electrical point of view, all elements are connected in parallel as they are part of the same conductor/cathode.

### B. Volume of the Flow Field with Oxygen Consumption

The air inside the reservoir volume of the cathode has a certain oxygen concentration depending on the air flow rate and the stack current. Therefore, a change of the actual stack current will impact the oxygen concentration depending on the actual air flow rate. The concentration inside the reservoir is assumed to be equal (ideally mixture) inside one volume element. In case of a sudden increase of the stack current, the oxygen concentration will start to decrease constituting as a capacitance from an electrical point of view.

modelled as a simple current source in this case. A Servo\_Valve (or compressor) provides the air flow into the stack. It receives its set point from a flow controller which operates the stack to remain in constant stoichiometry. The actual fuel cell stack consists of the FC\_stack\_xxx and the reservoir/volume element model. The value of consumed oxygen is given to the reservoir model resulting in the concentration to decrease. The oxygen concentration inside the reservoir is then used in the FC stack model to determine its actual point of operation.

A more detailed implementation as shown in Fig. 9 takes into account the reduction of oxygen concentration while the air flows through the cathodes. Therefore, the reservoir is subdivided in several elements (here: 4). The air passes from the first element at the inlet to the following elements to the output. The subsystem FC\_Stack\_cap from Fig. 6 automatically vectorizes to the respective number of reservoir elements and considers them to be connected electrically in parallel.

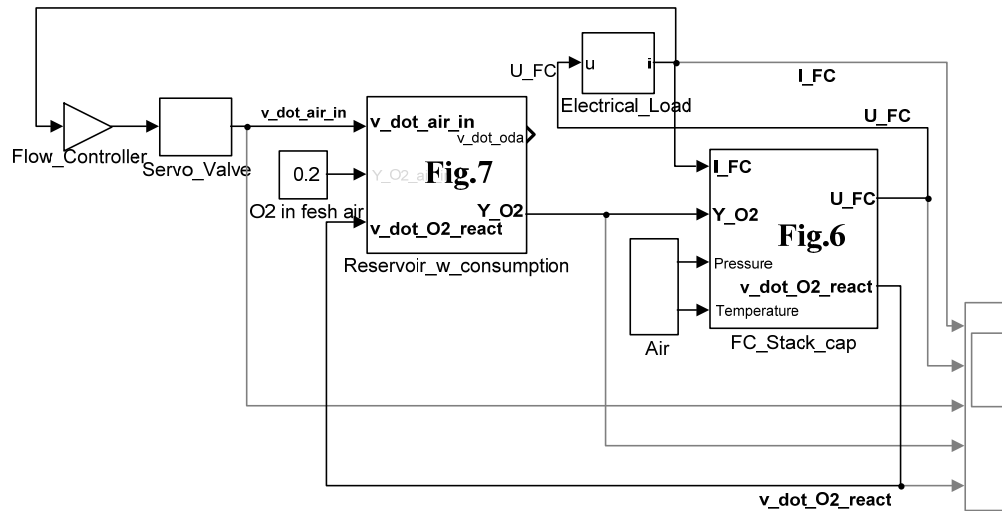

Fig. 8 Fuel cell system model with stack, single cathode volume, servo valve / compressor and air flow controller

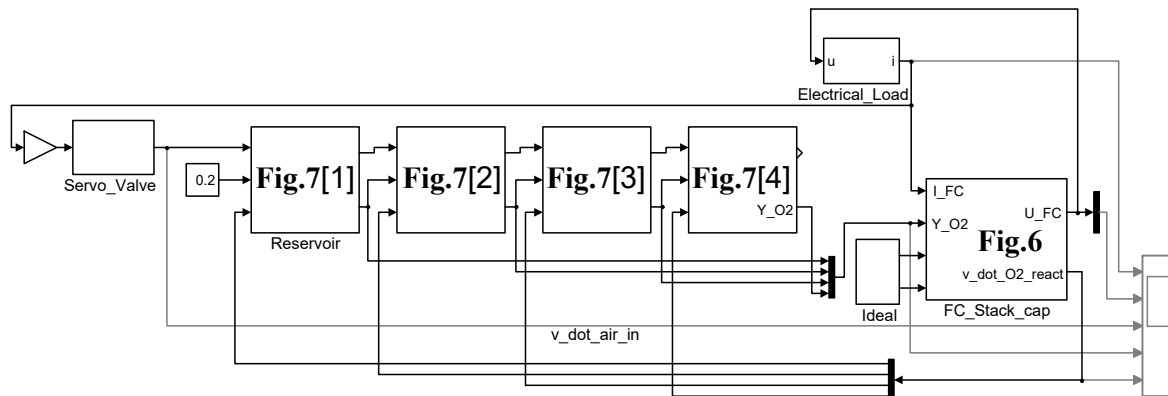

Fig. 9 Fuel cell system model with stack, four cathode volume elements, servo valve / compressor and air flow controller

The plots in Fig. 10 illustrate the behavior of the system in result of a current load step. When the transient occurs, the oxygen concentration inside the reservoir starts to decrease resulting in the stack voltage to drop. The oxygen concentration and the voltage recover as soon as the compressor has set the air supply to the required flow rate. However, both load steps have the same magnitude, and apparently the second one has a smaller impact to the output characteristics. Hence, the stack reacts less sensitive to load variations when a high air flow is provided. These results are verified by the observations during the test campaign.

The simulation results from the model with the single cathode volume on Fig. 8 are indicated with “M”, while the results from the discretized model in Fig. 9 refer to the respective volume element number. Naturally, the oxygen concentration,  $Y_{O_2}$ , decreases on its way through the flow field. Furthermore, the value of the single reservoir model matches  $Y_{O_2}[4]$  at the outlet of the discretized model. It should be considered that this is also the value which is acquired when measuring the static  $U$ - $I$ - $Y_{O_2}$  – polarization table at a test rig. Hence, there is a small mismatch in the cell voltage when the same polarization table is used in both

models. However, the error becomes more relevant at a large load step when the cell starts suffering air starvation beginning from the outlet. Another obvious fact is that the oxygen consumption of the elements is higher at the inlet than at the outlet resulting in an unequal electrical current density distribution inside a cell. This is even more apparent in transient cases.

#### IV. FC EMULATOR

A Fuel Cell emulator has been developed in AIRBUS test center in Toulouse. The emulator is based on the model described in Section III concerning single reservoir modelling. Indeed, the behavior of the single reservoir model output voltage fits with the multiple reservoirs model.

##### A. General Description

The FC stack considered for the real-time model is characterized by a 2D lookup table. In the table, the cell voltage is defined in function of the oxygen rate and the cell current. A 1 V max voltage cell is considered.

The stack is supposed composed by 220 cells. The 3D plot in Fig. 11 presents the static characteristic of the whole stack.

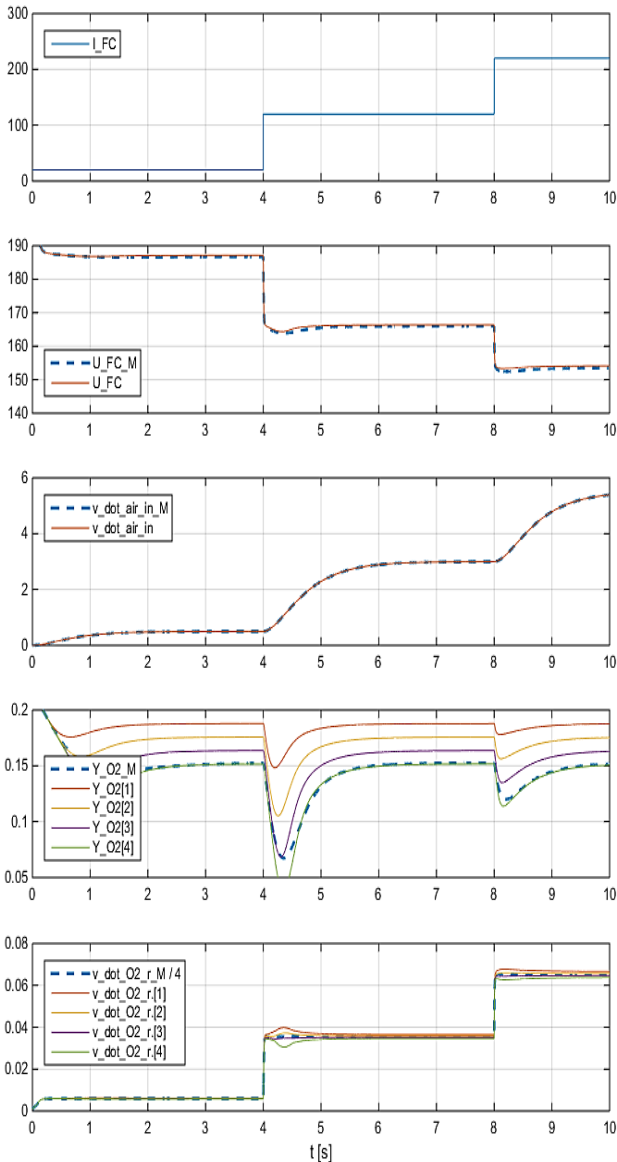

Fig. 10 Simulation of electrical transients with single and discretized volume elements

A principle scheme of the FC Cell emulator is presented in Fig. 12. Four main elements are present:

- **DC Voltage Controlled Power Supply:** The AL3000 DC power supply from ZENONE has been used to emulate the FC stack output voltage. Maximum power for this unit is 80kW with maximum output voltage 300V. The power supply allows controlling the output voltage by means of an analog input 0-10V. The bandwidth of the power supply is large enough to correctly achieve dynamics required by the FC model.
- **Measurement Board:** The measurement board function is to measure voltage and current at the power supply output. Two Hall Effect sensors are mounted for current and voltage measures. LEM LA 150-P and LV25P are

used respectively for current and voltage sensing. Sensor outputs are connected to the control board.

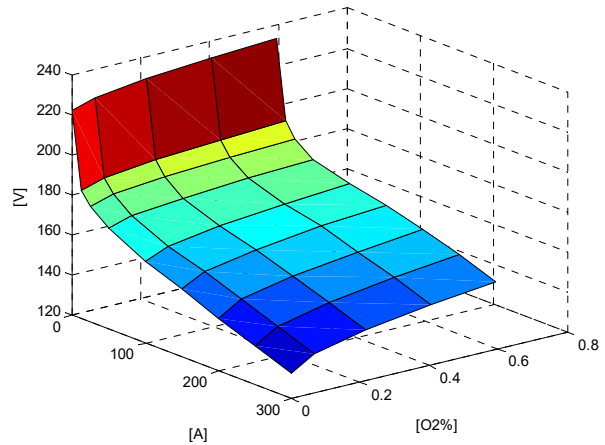

Fig. 11 Static characteristic of 220 cells stack

- **Control Board:** The control board contains the real-time hardware which implements the FC model and regulates the reference voltage for the DC power supply. The hardware used is the National Instruments myRIO-1900 based on FPGA Xilinx Z-7010.

Two ADC are used to acquire output current and voltages from measurement board.

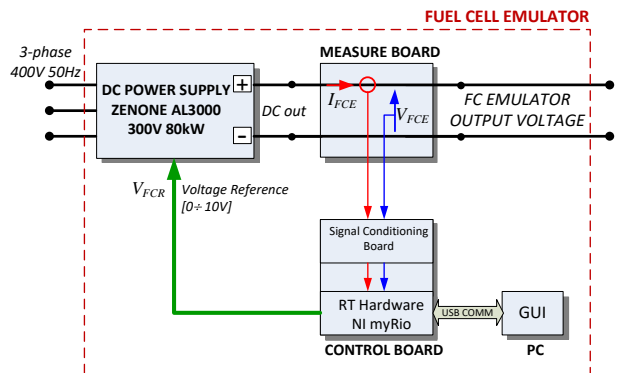

Fig. 12 FC emulator principle scheme

One DAC is used to generate the reference for the power supply which is a voltage between 0 and 10 V.

An USB connection is used to communicate with a GUI running on a PC.

LabView has been used to implement the Fuel Cell model and to program the real-time target.

The code is basically composed by two time loops. The first one is a deterministic loop which runs at 5000 kHz and which contains the real-time model. The second one is a low priority time loop running at 100 Hz and which contains all tasks concerning communication with the GUI.

▪ *Graphical User Interface:* A Graphical User Interface has been developed using LabView and run on a laptop connected to the myRIO using USB.

This GUI allow exchanging some parameters with the myRIO like current and voltage measured, temperature, pressure or transmits some commands like the Start/Stop of the emulation.

### B. FC Emulator Testing and Validation

A validation phase for the FC emulator was necessary in order to check the good behavior of the system. In order to fulfill this task, several tests were carried out in Airbus laboratory using resistive loads. Emulator current and voltage were recorded and those data have been given as input to the Simulink model in order to compare simulated and the experimental results.

Input parameters for the emulator were:

- Initial oxygen concentration inside the cathode is 20%.
- air pressure inside the cathode volume is 1e6
- air temperature inside the cathode volume is 250°C

Profiles recorded for current and power are presented in Fig. 13. Several load steps have been given up to 11kW. Maximum current was about 60A.

Current profile recorded has been used as input for the Simulink model simulation. Fuel Cell output voltage simulated and the emulator voltage recorded are compared in Fig. 14. As presented in the figure, simulation results and experimental results match quite well.

A zoom of the voltages is shown in Fig. 15. Let us highlight that the average voltages follow the same shape except for the emulator voltage ripple which is less than 1 V.

As conclusion, the static electrical characteristics for the fuel cell emulator are reported in Fig. 16. On the same axes the measured output voltage and current have been plotted in black dotted line.

Many others load profiles were tested, and in each case, simulation results validated the experimental results and the correct functioning of the fuel cell emulator.

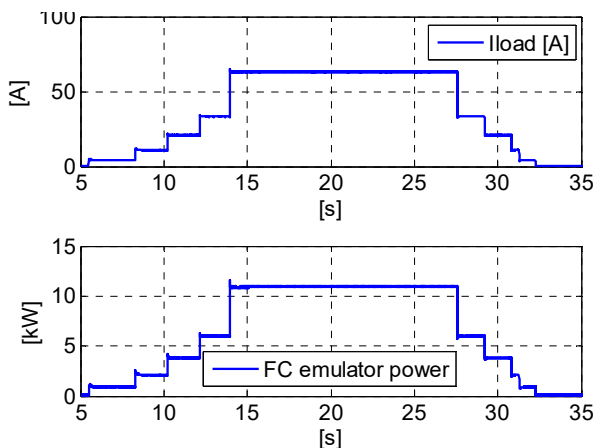

Fig. 13 Emulator Current and Power

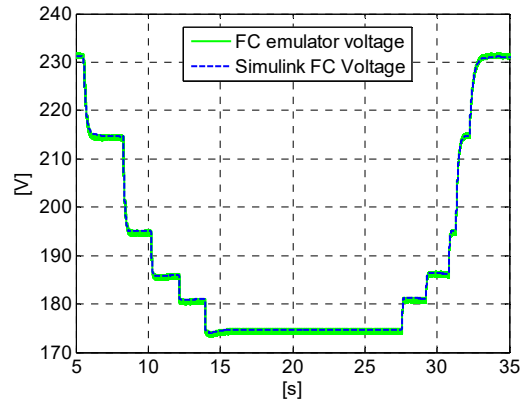

Fig. 14 FC output voltage comparison between simulation and experimental results

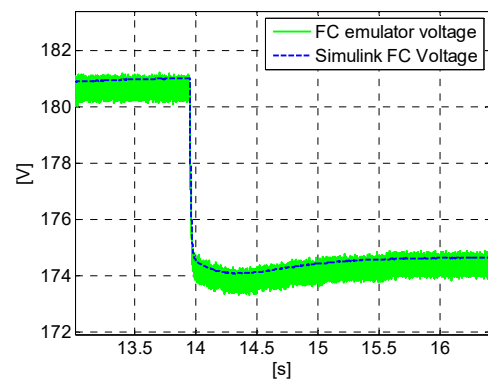

Fig. 15 Zoom

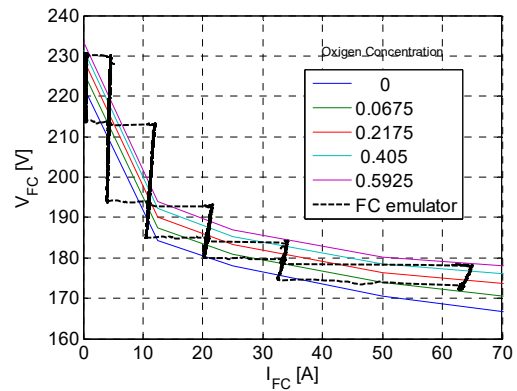

Fig. 16 Static characteristics of the FC emulator

## V. CONCLUSIONS

An empirical Fuel Cell model which is used for real-time emulation in aerospace testing activities is presented in this paper. The model has been derived from characterization tests on a commercial Fuel Cell. This model is implemented in real-time computation device providing the voltage reference to a power supply to represent the dynamic electrical behavior of a fuel cell system. Test results obtained on the emulator match simulation results and allow validating the realistic behavior



of the system, compared to the fuel cell tests. The results of this work demonstrate a way to share dynamic fuel cell behavior between involved development teams which is a key activity in an early stage of a development project, when the design of the overall system is still not fixed.

## REFERENCES

- [1] Advisory Council for Aeronautics Research in Europe. Strategic Research Agenda, Volume 1, 2002.
- [2] European Commission: Flightpath 2050: Europe's vision for aviation; maintaining global leadership and serving society's needs; report of the high-level group on aviation research. Luxembourg, Publ. Office of the European Union, 2011.
- [3] Isikveren, A.: Realizing flightpath 2050: An investigation of potential technological solutions. In: SAE 2011 AeroTech Congress, Toulouse, 2011, SAE International.
- [4] Enzinger, M.: Technology programs- multifunctional fuel cell application. In: Deutscher Luft- und Raumfahrt Kongress 2010, Hamburg, 2010, Deutsche Gesellschaft für Luft- und Raumfahrtforschung.
- [5] Gans, H., Stolte, R.-H., Piezunka, V.: Fuel cell emergency system, US 2008/0210812 A1, 2008
- [6] Hoffjann, C., Schuldzig, H.: Fuel cell system for the supply of drinking water and oxygen. US 2008/0299432 A1, 2008.
- [7] Hoffjann, C., Schuldzig, H., Stolte, R.-H.: System and process for the reduction of harmful substances in engine exhaust gases. US2011/0048026 A1, 2011.
- [8] Hoffjann, C., Wolff, C.: Engine for propelling an aircraft and aircraft having at least one engine and at least one hydrogen tank. US2015/0308383 A1.
- [9] Wangemann, J., Lüdders, H. P., Kaiser, A.: Fuel cell system in a bipolar high-voltage network and method for operating a bipolar high-voltage network. US2015/0244277 A1.
- [10] Wangemann, J., Lüdders, H. P., Zandstra, S., Drechsel, P.: Emergency power supply system, aircraft having such an emergency power supply system and a method for providing at least electric power and hydraulic power in case of an emergency in an aircraft. US 2016/0090189 A1; EP 3 001 548 A1.
- [11] Kallergis, K., Beuermann, R.: Brandschutz und Brandbekämpfung im Flugzeug—Vergangenheit / Gegenwart / Zukunft. In: Deutscher Luft- und Raumfahrt Kongress 2010, Hamburg, 2010, Deutsche Gesellschaft für Luft- und Raumfahrtforschung.
- [12] Law, B.: Airbus multifunctional fuel cell integration. In: Deutscher Luft- und Raumfahrt Kongress 2012, 2012, Deutsche Gesellschaft für Luft- und Raumfahrtforschung.
- [13] Keim, M.: Multifunctional fuel cell system in an aircraft environment: An investigation focusing on fuel tank inerting and water generation. Aerospace Science and Technology 29 (2013).
- [14] Kallo, J., Renouard-Vallet, G., Saballus, M., Schmithals, G., Schirmer, J., Friedrich, K. A.: Fuel Cell System Development and Testing for Aircraft Applications. 18th World Hydrogen Energy Conference 2010, 2010, ISBN: 978-3-89336-655-2.
- [15] Lüdders, H. P., Strummel, H., Thielecke, F.: Model-based development of multifunctional fuel cell systems for More-Electric-Aircraft. CEAS Aeronaut J (2013) 4:151-174, DOI 10.1007/s13272-013-0062-3.
- [16] Kaiser, A., Wangemann, J., Höger, W., Schawe, D., Design of a Lightweight DC/DC Converter Providing Fault Tolerance by Series Connection of Low Voltage Sources. More Electric Aircraft Conference, Bordeaux, 2012.
- [17] Fourie, F., Andriamisaina, M., "Large aircraft integration rig and tests results", More Electric Aircraft Forum, Barcelona, 2009.
- [18] Pukrushpan, J. T., Stefanopoulou, A. G., Peng, H., "Control of Fuel Cell Power Systems", Springer 2004, ISBN 978-1-4471-3792-4.
- [19] Pukrushpan, J. T., Stefanopoulou, A. G., Peng, H., "Control of Fuel Cell Breathing: Initial Results on the Oxygen Starvation Problem", University of Michigan, Ann Arbor.