

Adaptive Discharge Time Control for Battery Operation Time Enhancement

Jong-Bae Lee, Seongsoo Lee

Abstract—This paper proposes an adaptive discharge time control method to balance cell voltages in alternating battery cell discharging method. In the alternating battery cell discharging method, battery cells are periodically discharged in turn. Recovery effect increases battery output voltage while the given battery cell rests without discharging, thus battery operation time of target system increases. However, voltage mismatch between cells leads two problems. First, voltage difference between cells induces inter-cell current with wasted power. Second, it degrades battery operation time, since system stops when any cell reaches to the minimum system operation voltage. To solve this problem, the proposed method adaptively controls cell discharge time to equalize both cell voltages. In the proposed method, battery operation time increases about 19%, while alternating battery cell discharging method shows about 7% improvement.

Keywords—Battery, Recovery Effect, Low-Power, Alternating Battery Cell Discharging, Adaptive Discharge Time Control.

I. INTRODUCTION

As batter lifetime becomes more and more important in modern portable devices, battery scheduling [1], [2] is intensively studied to extend battery operation time. It schedules battery charging and discharging of multiple battery cells based on the battery model, workload analysis, and mathematical task scheduling.

Recently, alternating battery cell discharging method [3] was proposed based on recovery effect [4]. Recovery effect increases output voltage while the given battery cell rests without discharging. In the alternating battery cell discharging method, battery cells are divided into several groups. They are periodically discharged in turn, and only one group supply system power while the others rest [3]. Output voltages of all cells increase while they rest without discharging, thus battery operation time of target system increases.

However, in the alternating battery cell discharging method, voltage mismatch between cells leads two problems. First, voltage difference between cells induces inter-cell current with wasted power. Second, it degrades battery operation time, since system stops when any cell reaches to the minimum system operation voltage. To overcome this problem, it is required to equalize all cell voltages.

In this paper, we propose an adaptive discharge time control method, where all cell voltages are equalized by adjusting cell discharge time. In the proposed method, cell discharging time is adaptively controlled, i.e. discharging time of each cell is

determined to be proportional to the voltage difference between the target cell and the other cell. Thus, battery cell with higher output voltage is discharged longer, and its output voltage decreases more, which equalizes cell output voltages.

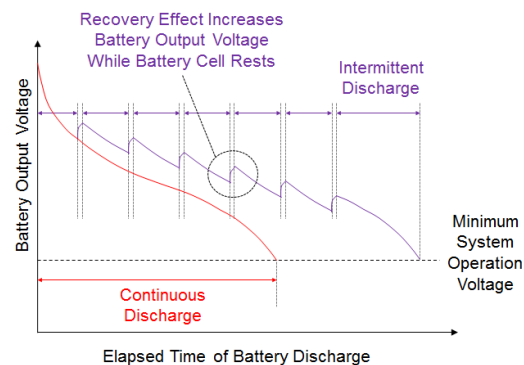

Fig. 1 Recovery effect (modified from [3], [5], and [6])

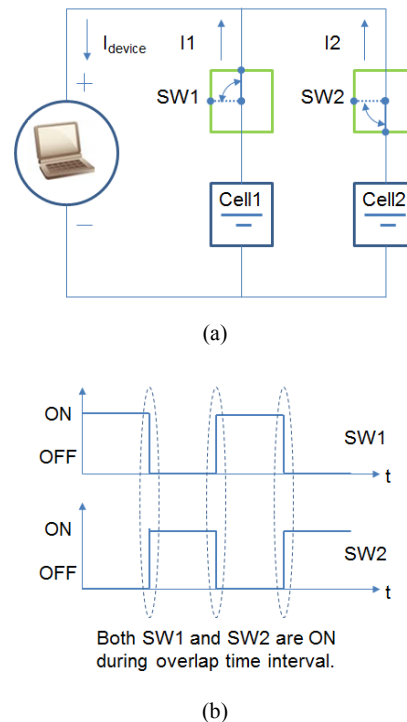

Fig. 2 Alternating battery cell discharging method (a) Battery connection (b) Switch connection (modified from [3])

Jong-BaeLee is with Soongsil University, 511 Sangdo-dong, Dongjak-gu, Seoul, 156-743 Korea (e-mail: jb007jb@ssu.ac.kr).

Seongsoo Lee is with Soongsil University, 511 Sangdo-dong, Dongjak-gu, Seoul, 156-743 Korea (phone: +82-2-820-0692, e-mail: ssllee@ssu.ac.kr).

II. PROBLEMS OF ALTERNATING BATTERY DISCHARGING METHOD

In general, recovery effect increases output voltage when the given battery cell rests without discharging, as shown in Fig. 1. From this, alternating battery cell discharging method was proposed, as shown in Fig. 2. Cell1 and cell2 are discharged alternately by SW1 and SW2, respectively. SW1 and SW2 are exclusively ON, but they are both ON with very short overlap time interval to continuously provide system power during cell alternation.

System power consumption varies from time to time. So output voltage of cell1 and cell2 is also different due to different power consumption of cell1 and cell2. In overlap time interval, both SW1 and SW2 are ON, so different output voltage of cell1 and cell2 are connected with each other. This induces inter-cell current, as shown in Fig. 3. When cell1 voltage > cell2 voltage, cell1 current flows to both target system and cell2, and cell1 current increases. Similarly, when cell1 voltage < cell2 voltage, cell2 current flows to both target system and cell1, and cell2 current increases. This inter-cell current is not supplied to target system, so it wastes battery power.

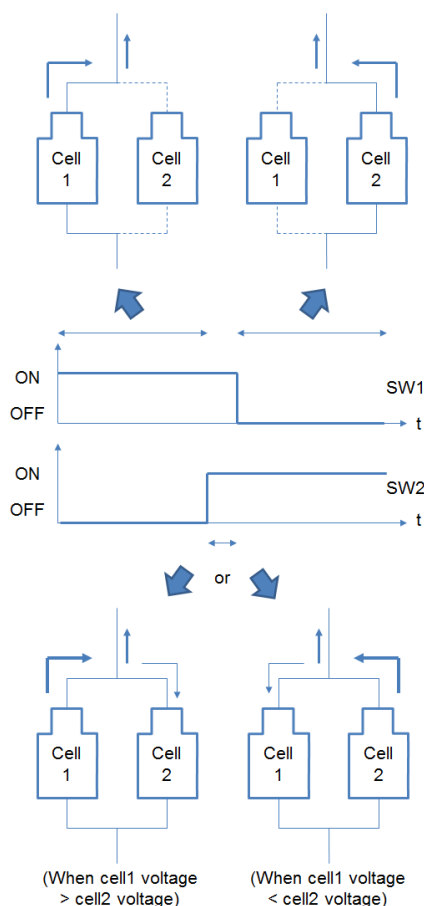

Fig. 3 Inter-cell current in alternating battery cell discharging method

Furthermore, voltage difference between cell1 and cell2 also degrades battery operation time, as shown in Fig. 4. In general, system stops its operation when battery output voltage reaches to the minimum system operation voltage. Fig. 4 (a) shows battery operation time of parallel battery cell discharging method, where output voltages of cell1 and cell2 are equal. Fig. 4 (b) shows battery operation time of alternating battery cell discharging. Although total energy stored in cell1 and cell2 are same in Figs. 4 (a) and (b), battery operation time becomes shorter in alternating battery cell discharging.

III. PROPOSED ADAPTIVE DISCHARGE TIME CONTROL METHOD

Although alternating battery cell discharging method suffers from above two problems, it shows better battery operation time than parallel battery cell discharging method by 7% [3]. However, battery operation time can be further extended if alternating battery cell discharging is performed with cell voltage balancing. In this paper, we propose an adaptive discharge time control method to reduce above two problems. Since power consumption of cell1 and cell2 is different due to the variation of system power consumption, the proposed method compensates this difference by making a cell with higher voltage to have longer discharge time. This can be performed by making discharge time to be proportional to the voltage difference.

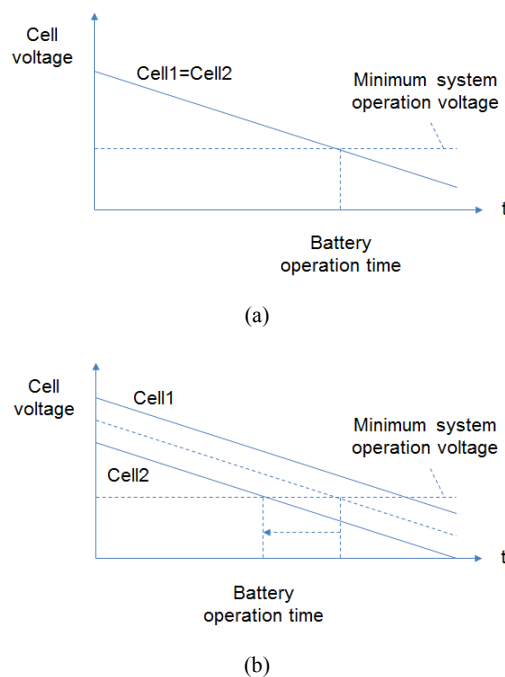

Fig. 4 Degradation of battery operation time in alternating battery cell discharging method (a) Parallel battery cell discharging method (b) Alternating battery cell discharging method

Fig. 5 illustrates the proposed adaptive discharge time control method. For each period of alternating cell discharging, cell voltages V_1 and V_2 are measured. From V_1 and V_2 , cell

discharge times t_{d1} and t_{d2} are determined as $T_0 + \alpha(V_1 - V_2)$ and $T_0 + \alpha(V_2 - V_1)$. To avoid too small or too long discharge time, t_{d1} and t_{d2} are limited within a range of $0.5T_0 \sim 1.5T_0$. Note that

$t_{d1} + t_{d2} = 2T_0$, so alternating period is not changed. Δ is overlap time interval, and it is determined as short as it maintains stable system operation.

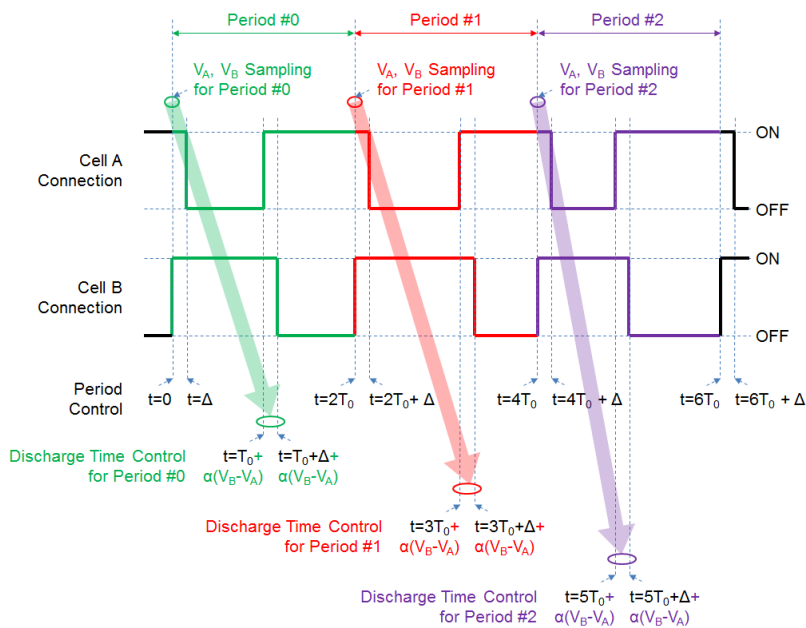

Fig. 5 Proposed adaptive discharge time control method

TABLE I
MEASUREMENT RESULT

Experiment	Conventional Parallel	Proposed T0=10s $\alpha=100s/V$ $\Delta=0.1s$	Proposed T0=15s $\alpha=100s/V$ $\Delta=0.1 sec$	Proposed T0=20s $\alpha=100s/V$ $\Delta=0.1 sec$	Proposed T0=10s $\alpha=200s/V$ $\Delta=0.1 sec$	Proposed T0=15s $\alpha=200s/V$ $\Delta=0.1 sec$
Operation Time	51393s	57268s	58175s	61263s	59213s	58175s
Gain	-	11.4%	13.2%	19.2%	15.2%	13.2%

IV. MEASUREMENT RESULTS

Battery cell discharge characteristics have quite large variation up to 20% even if the battery cells are chosen from same factory lot with same battery model. To reduce this variation, we used Cyclor™ equipment, as shown in Fig. 6. Cyclor™ is an automated battery discharging machine with 32 channels. Each channel can be independently controlled with predefined voltage/current/power patterns, as shown in Fig. 7. Repetition of discharging experiments with different battery cells can significantly reduce the irregularity of cell characteristics, but it usually takes too long time. Cyclor™ can significantly reduce experiment time.

In the experiment, we measured power pattern of iPad2™ with music player application. This power pattern is loaded into Cyclor™. Two 1600mAh Li-ion batteries are connected to two programmable channels of Cyclor™. We performed 10 repeated discharging experiments with 32 battery cells (=16 pairs of 2 alternating cells). T_0 and α are varied as 10~15 second and 100~200 second/V, respectively. Δ is fixed as 0.1 second (= minimum time step of Cyclor™), since it is better to shorten overlap time interval.

Table I shows the measurement results. From Table I, the proposed adaptive discharge time control method improves the battery operation time by 19.2%. In [3], gain of alternating battery cell discharge method is 7%, so the proposed method is quite effective for battery operation time enhancement.

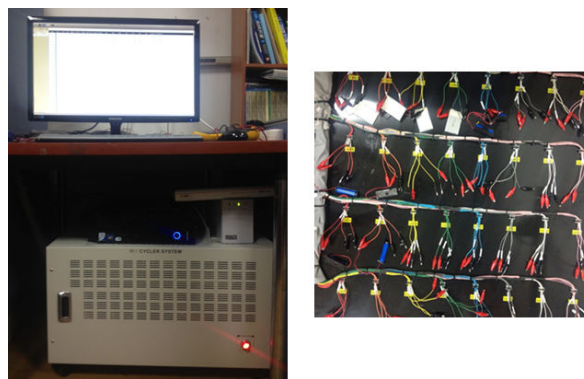

Fig. 6 Cyclor™— automated battery discharging machine with 32 independently-controllable channels

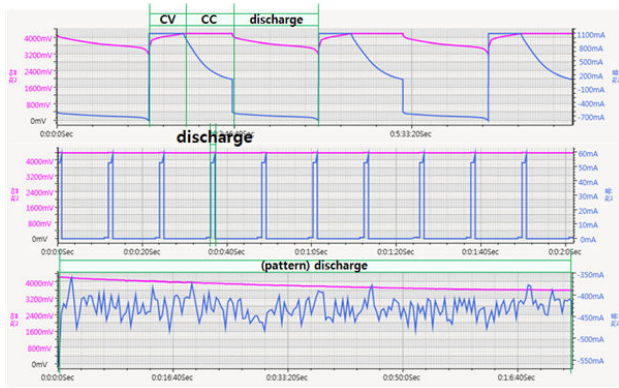

Fig. 7 Cyclers™ operation with predefined voltage/current/power patterns

V. CONCLUSION

Alternating battery cell discharging method periodically discharges battery cells in turn, and battery operation time increases due to recovery effect. However, it suffers from various problems due to cell voltage mismatch.

In this paper, we propose an adaptive discharge time control method, where discharging time of each cell is determined to be proportional to the cell voltage difference. Thus, battery cell with higher output voltage is discharged longer, and its output voltage decreases more, which equalizes cell output voltages.

Measurement results show that the battery operation time increased by 19.2%, while it increased by only 7% in alternating battery cell discharging method. So it is quite effective for battery operation time enhancement.

ACKNOWLEDGMENT

This research was supported by the MSIP (Ministry of Science, ICT & Future Planning), Korea, under University ITRC support program (NIPA-2013-H0301-12-2006) supervised by the NIPA (National IT Industry Promotion Agency).

This research was also supported by ETRI SW-SoC R&BD Center, Human Resource Development Project, funded by the MSIP (Ministry of Science, ICT & Future Planning), Korea.

REFERENCES

- [1] M. Jongerden, B. Haverkort, H. Bohnenkamp, and J. Katoen, "Maximizing System Lifetime by Battery Scheduling", *Proceedings of IEEE/IFIP International Conference on Dependable Systems and Networks*, pp. 63-72, 2009.
- [2] H. Kim and K. Shin, "Scheduling of Battery Charge, Discharge, and Rest", *Proceedings of IEEE Real-Time Systems Symposium*, pp. 13-22, 2009.
- [3] J. Lee and S. Lee, "Battery Operation Time Enhancement Based On Alternating Battery Cell Discharge", to appear in *World Academy of Science, Engineering, and Technology*, vol. 82, 2013.
- [4] M. Doyle, and J. Newman, "Analysis of capacity-rate data for lithium batteries using simplified models of the discharge process", *Journal of Applied Electrochemistry*, vol. 27, no. 7, pp. 846-856, Jul. 1997.
- [5] Y. Jang, H. Yang, and S. Lee, "Battery-aware wireless video transmission based on battery recovery effect", *Proceeding of IEEE Conference on Consumer Electronics*, pp. 418-419, 2012.

- [6] T. Martin, "Balancing batteries, power, and performance: system issues in CPU speed-setting for mobile computing", *PhD Thesis, Carnegie Mellon University*, 1999.

Jong-Bae Lee received B.S. degree in E.E from Soongsil University, Korea, in 2011. He is currently pursuing M.S degree in E. E. Soongsil University, Korea. His research interests include high efficiency video coding, semiconductor, digital circuit, multimedia, and ultra-low-power analog circuit.

Seongsoo Lee received B.S, M.S, and Ph.D. degrees in E.E. from Seoul National University, Korea in 1991, 1993, and 1998, respectively. In 1998-2000, he was a research associate in Institute of Industrial Science, University of Tokyo, Japan. In 2000-2002, he was a research professor in Department of Electronic Engineering, Ewha Womans University, Korea. He joined School of Electronic Engineering at Soongsil University, Korea in 2002, where he is currently an associate professor. His research interests include low-power SoC, multimedia SoC, and battery management SoC.