

A Voltage Based Maximum Power Point Tracker for Low Power and Low Cost Photovoltaic Applications

Jawad Ahmad, and Hee-Jun Kim

Abstract—This paper describes the design of a voltage based maximum power point tracker (MPPT) for photovoltaic (PV) applications. Of the various MPPT methods, the voltage based method is considered to be the simplest and cost effective. The major disadvantage of this method is that the PV array is disconnected from the load for the sampling of its open circuit voltage, which inevitably results in power loss. Another disadvantage, in case of rapid irradiance variation, is that if the duration between two successive samplings, called the sampling period, is too long there is a considerable loss. This is because the output voltage of the PV array follows the unchanged reference during one sampling period. Once a maximum power point (MPP) is tracked and a change in irradiation occurs between two successive samplings, then the new MPP is not tracked until the next sampling of the PV array voltage. This paper proposes an MPPT circuit in which the sampling interval of the PV array voltage, and the sampling period have been shortened. The sample and hold circuit has also been simplified. The proposed circuit does not utilize a microcontroller or a digital signal processor and is thus suitable for low cost and low power applications.

Keywords—Maximum power point tracker, Sample and hold amplifier, Sampling interval, Sampling period.

I. INTRODUCTION

WORLDWIDE interest in sustainable energy is increasing due to the energy crisis and the aggravated environmental pollution. Solar energy is an important renewable energy source. As compared to other energy sources, solar energy is clean, inexhaustible and free. Photovoltaic (PV) arrays are used to convert solar energy into electrical energy. But the PV systems have two major problems: the conversion efficiencies of the PV arrays is low (9-16%) especially under low irradiation conditions and the

Jawad Ahmad is with Electrical and Computer Engineering Department, Hanyang University, 1271 Sa-3dong, Songnuk-gu, Ansan 425-791, Kyeonggi-do, South Korea (Tel: 82-31-4062325, Fax 82-31-4003799, email: jawad_matta@yahoo.com. He is doing MS in Electronic Engineering under the Higher Education Commission, Government of Pakistan, program titled: "MS Level Training in Korean Universities and Industries."

Professor Hee-Jun Kim is with Electrical and Computer Engineering Department, Hanyang University, 4 1-dong, Ansan 425-791, South Korea (email: hjkim@hanyang.ac.kr)

amount of electric power generated by solar arrays varies with the ambient weather conditions [1].

The solar V-I characteristic is highly nonlinear and changes with irradiation and temperature as shown in Fig. 1 and 2 [2]. In general, there is a unique point on the V-I curve called the maximum power point (MPP) at which the PV array operates at maximum efficiency. Maximum power point trackers (MPPT) are used to maintain the PV array's operating point at the MPP to maximize its output.

Various MPPT techniques are described in [1] and [3]. Of these methods, the perturb and observe (P&O) and the incremental conductance (IC) method are considered to be the most efficient [1].

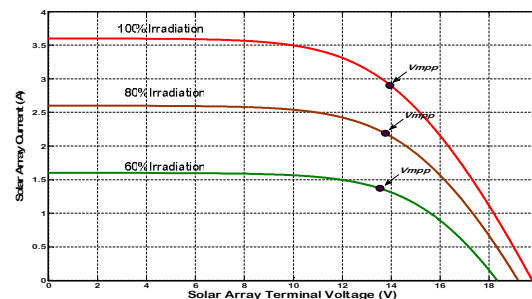

Fig. 1 Nonlinear VI characteristics of the solar panel for different irradiation

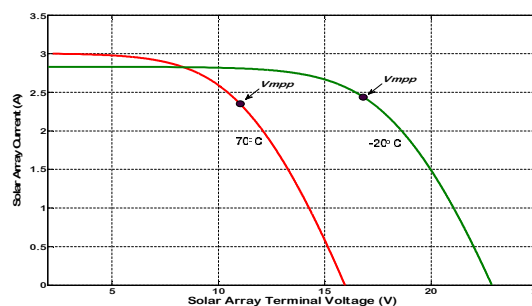

Fig. 2 Temperature impact on the VI characteristics of the solar panel

In the P&O method the MPP is tracked by repeatedly increasing or decreasing the output voltage of the PV array at the MPP. This method not only has relatively simple control

algorithm but also tracks the MPP well. However, in the normal weather conditions, the operating point of the PV array oscillates around the MPP giving rise to wasting of some amount of the available energy [3]. In rapidly changing atmospheric conditions, this method takes considerable time to track the MPP and during this time a significant amount of power is lost [4]. The IC method is developed to remove the drawbacks of the P&O method. The IC method tracks the MPP of the PV array by comparing incremental conductance with the instantaneous one. As a result, under rapidly changing atmospheric conditions, the IC method tracks the MPP well. But this method has a disadvantage, that it requires a complex control circuit.

Another common MPPT technique is the current based MPPT. This technique uses the fact that the operating current at the MPP of a PV array is linearly proportional to its short circuit current [3]. Under rapidly changing atmospheric conditions this method has fast response speed of tracking the MPP. But for the online measurements of PV array short circuit current make the current based MPPT hardware more complicated and expensive [5].

The voltage based MPPT technique is based on the fact that the PV array voltage corresponding to the maximum power exhibits a linear dependence with respect to the array open circuit voltage for different irradiation and temperature levels, i.e.,

$$V_{mpp} = M_v \cdot V_{oc} \quad (1)$$

Where V_{mpp} is the maximum power point voltage, V_{oc} is the open circuit voltage of the PV array and M_v is the voltage factor. The voltage factor has the value between 0.7–0.8 depending upon the PV array characteristics. Fig. 3 gives the block diagram of the voltage based MPPT.

To operate the PV panel at the MPP, the actual PV array voltage V_{pv} is compared with the reference voltage V_{ref} which corresponds to the V_{mpp} . The error signal is then processed to make $V_{pv} = V_{ref}$. Normally, the panel is disconnected from the load momentarily to sample its open circuit voltage. The fraction of the open circuit voltage corresponding to the V_{mpp} is measured and is kept in a hold circuit for the converter to function as V_{ref} for the control loop [6].

Even though the voltage based MPPT method is classified as quasi seek method [3], but research has shown that this method has efficiency comparable to the P&O and IC method under normal illumination conditions [7].

II. LIMITATIONS OF VOLTAGE BASED MPPT

The main disadvantage of this method is that there is momentary power loss due to the disconnection of the load from the PV array for the sampling of its open circuit voltage. Reference [4] has suggested the use of pilot PV array which has the same characteristics as the main PV array. By using that method the problem of opening the PV array has been overcome. However, if there is mismatch between the properties of the main and the pilot PV array, then the system

will never operate at the MPP. The method in [4] can also be unsuitable for cost and space constrained applications [3].

Another challenge in the design of voltage based MPPT is the choice of the duration between two successive samplings of the PV array voltage, called the sampling period. If the sampling period is too long, as in case of [6], there is considerable power loss. This is because the output voltage of the PV module follows the unchanged reference during one sampling period. Once an MPP is tracked and a step in irradiance occurs between two consecutive samplings, then the new MPP is not calculated until the next sampling of the array voltage. Consequently, the method initially achieves an incorrect MPP instead of the current one [1]. The new MPP is achieved only after the next sampling of the array voltage. This problem is more pronounced when the irradiation changes quickly. Additionally, when sample and hold amplifier is used, as in this paper, and the sampling period is too long, the hold capacitor will droop. This causes V_{ref} to change during the sampling period and, as a result, the PV operating point deviates from the MPP. To overcome this problem, extended hold time S&H is used [8, 13]. In this arrangement extended hold time is achieved by stacking two S&H circuits in chain. By adopting this method, the problem of deviation of the PV operating point from the MPP is mitigated, but this arrangement increases the number of components and the system cost.

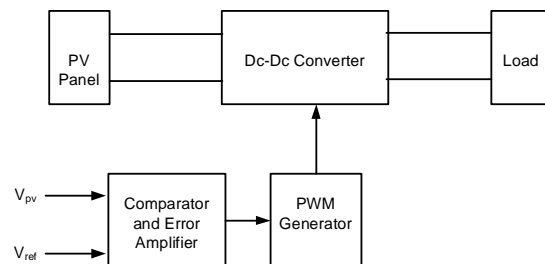

Fig. 3 Block diagram of the voltage based MPPT

In this paper an MPPT circuit is proposed which addresses these problems. Also in the proposed circuit, the sampling interval has been reduced considerably. The proposed MPPT does not utilize microcontroller or a digital signal processor and is thus suitable for low cost and low power applications.

III. PROPOSED MPPT

In Fig. 4 is shown the circuit diagram of the proposed MPPT. S_0 is the static switch used for disconnecting the PV array from the load for the sampling of the array voltage [5]. D_0 is the reverse blocking diode, and S_1 is the main switching MOSFET. In the proposed MPPT the S&H has a fast acquisition time [11]. The reason for choosing the S&H with fast acquisition time is to reduce the length of the sampling interval and, consequently, the power annulment period. The S&H also has a low droop rate to avoid the deviation of the PV operating point from the MPP during the sampling period, as discussed in the previous section. The

sampling period is chosen to be 100ms. The combination of short sampling period and low droop rate of the S&H obviates the need for using extended hold time S&H thereby decreasing the number of components in the proposed MPPT. In the proposed MPPT, the PV array is disconnected from the load for sampling of its open circuit voltage. During the sampling interval the S&H is triggered into the sampling mode. The array voltage is sampled by the S&H and a fraction thereof is kept in the hold capacitor to act as V_{ref} for the converter to latch on to.

The length of the sampling interval and the sampling period is controlled by a 555 timer and a dual monostable multivibrator (MMV). This is shown schematically in Fig. 5. Both the MMVs are negative edge triggered [12]. The timer produces a falling edge after every 100ms which is the duration of the sampling

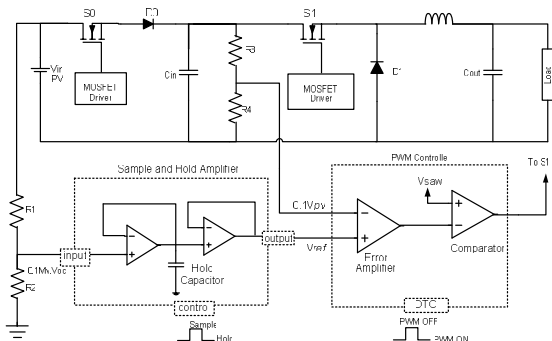

Fig. 4 Circuit diagram of the proposed MPPT

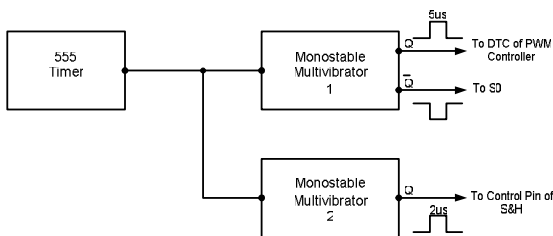

Fig. 5 Block diagram of the circuit controlling the sampling interval and the sampling period

period. The output pulse width at the true output of the MMV1 is $5\mu s$. As shown in Fig. 5, the true out put of the MMV1 connected to the dead time control (DTC) of the pulse width modulation (PWM) controller [10], to turn off its output during the sampling interval. The complementary output of the MMV1, which is connected to the driving circuit of S0, turns it off and the PV array is disconnected from the load for $5\mu s$.

The MMV2 is triggered into the timing state synchronously with the MMV1. The output of the MMV2 triggers the S&H into the sampling mode. To ensure that the PV array voltage is sampled well before the array is reconnected to the load and to make allowance for the hold mode settling time of the S&H, the width of the output pulse of the MMV2 is kept shorter than MMV1.

IV. EXPERIMENTAL RESULTS

The proposed MPPT was implemented and indoor testing of the circuit has been performed. For indoor testing, a variable DC voltage source was used in series with a variable resistor [9]. The DC power supply has a maximum power point at half of the source voltage. Therefore, the MPPT should always track the input voltage to the converter such that the input voltage to the converter is equal to the half of the power supply voltage. For this purpose the voltage factor in the prototype MPPT was taken to be 0.5. The converter switching frequency was fixed at 100 kHz. Figs. 6, 7, and 8 show the experimental results. In Fig. 6 the top oscilloscope trace indicates the signal at the output of the MMV1, the middle signal is that at the output of the MMV2, and at the bottom is the PWM signal at the main switching MOSFET gate. Fig. 6 indicates that the PWM signal to the main switching MOSFET is turned off during the sampling interval. The top oscilloscope trace in Fig. 7 indicates the acquisition of new V_{ref} at the output of the S&H and the bottom trace shows the current into the converter. As can be seen, that the current into the converter is disconnected during the sampling interval. Fig. 8 shows the MPP tracked by the proposed circuit during the indoor testing.

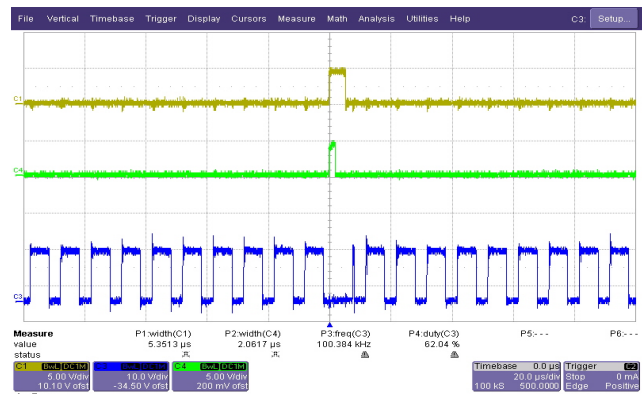

Fig. 6 The signal at the true output of MMV1(top),MMV2(middle), and the PWM signal at the MOSFET gate (bottom)

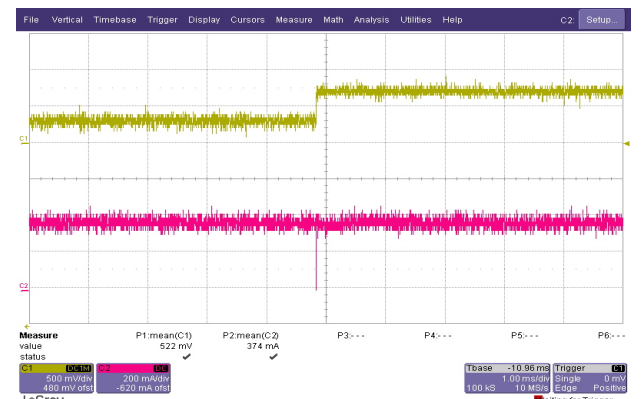

Fig. 7 The output of S&H (top), the input current to the converter (bottom)

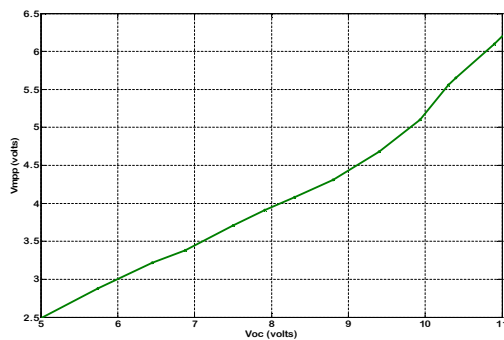

Fig. 8 The MPP tracked by the proposed circuit during indoor testing for a range of input voltage indicating $V_{mpp}/V_{oc}=0.5$

- [12] Fairchild Semiconductors Inc, 74LS221: Dual Non-Retriggerable One-Shot, Datasheet.
 [13] "Special sample and hold techniques", National Semiconductor, Application Report 294. Available: <http://www.national.com/an/AN/AN-294.pdf>

V. CONCLUSION

An open circuit voltage based MPPT has been designed and the indoor testing thereof has been performed. The proposed MPPT has short sampling time of $5\mu s$ and short sampling period of 100ms to overcome some of the disadvantages of the voltage based MPPT. The sample and hold circuit has also been simplified. The proposed MPPT does not utilize microcontroller or a digital signal processor and is thus suitable to low cost and low power applications.

REFERENCES

- [1] R. Faranda, S. Leva, V. Maugeri, "MPPT techniques for pv systems: energetic and cost comparison." Proceedings of IEEE Power and Energy Society General Meeting- Conversion and Delivery of Electrical Energy in the 21st Century, 2008, pp. 1-6.
- [2] M.A.S. Masoum, H. Dehbonei, "Design construction and testing of a voltage-based maximum power point tracker for small satellite power supply", Proceedings of 13th annual AIAA/USU Conference on Small Satellite, August 1999.
- [3] V. Salas, E. Olias, A. Barrado, and A. Lazaro, "Review of maximum power point tracking algorithms for stand alone photovoltaic systems." Solar Matter, Solar Cells, vol. 90, no. 11, pp. 1555-1578, July 2006.
- [4] Abu Tariq, M.S. Jamil, "Development of analog maximum power point tracker for photovoltaic panel." Proceedings of IEEE International Conference on Power Electronic Drive Systems, 2005, PEDS 2005, pp. 251-255.
- [5] M.A.S. Masoum, H. Dehbonei, "Theoretical and experimental analysis of photovoltaic systems with voltage and current based maximum power point trackers", IEEE Transactions on Energy Conversion, vol. 17, NO. 4, pp. 514-522, Dec 2002.
- [6] J.H.R. Enslin, M.S. Wolf, D.B. Snyman and W. Swiegers, "Integrated photovoltaic maximum power point tracking converter", IEEE Transactions on Industrial Electronics, vol 44, pp. 769-773, December 1997.
- [7] Farhan Simjee, Pai H. Chou, " Everlast: long life, supercapacitor-operated wireless sensor node", Proceedings of 2006 International Symposium on Low Power Electronics and Design, pp. 197-202.
- [8] M. Bodur and M. Ermis, " Maximum power point tracking for low power photovoltaic solar panels." Proceedings of 7th Mediterranean Electrotechnical Conference, 1994, pp. 758-761.
- [9] A.K. Mukerjee, Nivedita Dasgupta, " DC power supply used as photovoltaic simulator for testing mppt algorithms.", Renewable Energy, vol. 32, no. 4, pp. 587-592, 2007.
- [10] Patrick Griffith, "Designing switching voltage regulators with TL 494." Texas Instruments Application Report. Available: <http://focus.ti.com/lit/an/slva001d/slva001d.pdf>
- [11] Analog Devices Inc, AD 781: Complete 700ns Sample and Hold Amplifier, Datasheet.