

A Study on Unidirectional Analog Output Voltage Inverter for Capacitive Load

Sun-Ki Hong, Nam-Hee Byeon, Jung-Seop Lee, Tae-Sam Kang

Abstract—For Common R or R-L load to apply arbitrary voltage, the bridge traditional inverters don't have any difficulties by PWM method. However for driving some piezoelectric actuator, arbitrary voltage not a pulse but a steady voltage should be applied. Piezoelectric load is considered as R-C load and its voltage does not decrease even though the applied voltage decreases. Therefore it needs some special inverter with circuit that can discharge the capacitive energy. Especially for unidirectional arbitrary voltage driving like as sine wave, it becomes more difficult problem. In this paper, a charge and discharge circuit for unidirectional arbitrary voltage driving for piezoelectric actuator is proposed. The circuit has charging and discharging switches for increasing and decreasing output voltage. With the proposed simple circuit, the load voltage can have any unidirectional level with tens of bandwidth because the load voltage can be adjusted by switching the charging and discharging switch appropriately. The appropriateness is proved from the simulation of the proposed circuit.

Keywords—DC-DC converter, analog output voltage, sinusoidal drive, piezoelectric load, discharging circuit.

I. INTRODUCTION

PIEZOELECTRIC material is being used widely in various areas. Recently there are lots of trying that with piezoelectric material, smart oil-pressure pump, smart valve etc. are operated by special inverter as piezoelectric actuators. Some piezoelectric actuators are operated using H-bridge inverters which can apply positive or negative voltages to the R-C or piezoelectric loads [1]-[3]. Some loads made of single crystal need unidirectional voltage. For the case of piezoelectric pump, square-wave unidirectional voltage is applied to the load [4], [5]. However if the actuator is piezoelectric valve, the applied voltage needs to be arbitrary value. In usual cases, although the load needs to be operated under sinusoidal value of voltage, the average value controlled by PWM is enough. Even the load needs analog value of voltage, if the load is resistance or inductor, it usually has no problem. In the case of piezoelectric material, it is modeled as R-C load. Once the load is charged, the energy charged in the load doesn't discharged by itself and discharging circuit is needed. This means a special circuit is needed to operate the inverter as an analog voltage output inverter. In this study, to generate arbitrary voltage

Sun-Ki Hong is with the Dept. of Digital Control Eng., Hoseo University, Asan, Chungnam, 336-795, Korea (phone: +82-41-540-5674; e-mail: sunkih4@naver.com).

N. H. Byeon and J.S. Lee are now on M.S course with the Department of Information Control, Asan, Chungnam, 336-795, Korea (e-mail: dnlsksla@naver.com, qlbqlb@naver.com).

T.S. Kang is with the Dept. of Aerospace Information Eng., Konkuk University, Seoul Korea. (e-mail: ts kang@konkuk.ac.kr).

waveform to R-C load with dc voltage source, a special and simple circuit which has only two switches is proposed. In this circuit, an inductor which is for smoothing the load current and discharging resistance for discharging the energy from the load capacitance when reducing the output voltage are also added. The simulation and experiment results are compared to verify the proposed model.

II. TRADITIONAL INVERTER

A. Bidirectional Inverter

The bidirectional inverter which is well-known as H-bridge inverter is shown in Fig. 1. As can be seen in the figure, the applied load voltage on the R-C load can have positive or negative. If the switch S_1 and S_4 are on, the load voltage V_L is positive, if the switch S_2 and S_3 are on, V_L becomes negative. For the case of applying square-wave voltage to the load, although the inverter efficiency may be low, this kind of inverter can be used [4]. When the source is applied to the R-C load (ones the load is charged), somewhat large current can be flown when the applied voltage is switched from positive to negative or from negative to positive. To increase the efficiency or reduce the source capacity, energy recovery circuit can be used [5]. If the control variable is current, the current can be controlled with ease by switching the switches with voltage PWM when the current command increases. If the current command decreases, the charged energy in C_L should be discharged and usually R_L is not enough to dissipate the energy and this circuit becomes to need another circuit. With this circuit, unidirectional voltage driving is possible but 2 switches are enough. If the output voltage needs to be arbitrary value like as sinusoidal, it becomes difficult to realize because the source voltage is fixed as V_{DC} . One way is to adjust the source voltage but it is more complex problem if the load voltage should be continuously changed. Therefore some special circuit needs to be developed.

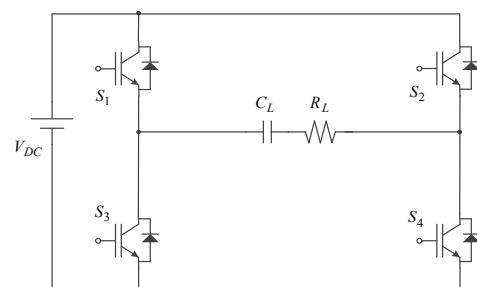

Fig. 1 Bidirectional voltage inverter (H-bridge inverter)

B. Unidirectional Inverter

Unidirectional inverter looks not common because unidirectional is a part of bidirectional. However some application devices like as single crystal piezoelectric actuator are operated under unidirectional voltage. Fig. 2 (a) shows an example of unidirectional inverter.

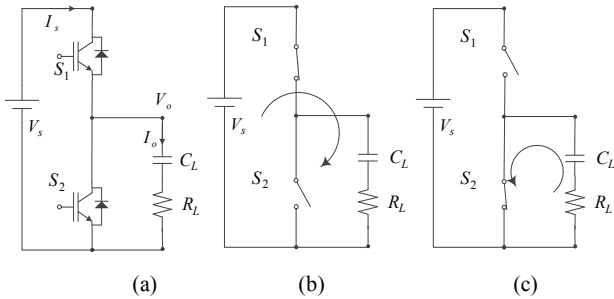

Fig. 2 Conventional circuit for unidirectional square wave drive (a) Conventional unidirectional inverter (b) In the case of applying the source voltage to the load (c) In the case of discharging the energy charged in the load

When switch S_1 is on, load capacitor is charged by V_s and the load voltage becomes V_s . In this state, if S_1 is off and S_2 is on as Fig. 2(c), the charged energy in C_L is discharged through the load resistor R_L . This kind of inverter can be also used for unidirectional square-wave voltage driving. However it is also difficult to apply sinusoidal voltage to the load because only V_s or 0 can be applied to the load. In addition, the inrush current is very large in the moment of switching, and the efficiency of this inverter cannot be high because all the energy should be discharged when the load voltage becomes 0. To enhance the efficiency, this circuit should be modified to have energy recovery circuit [5].

III. PROPOSED ANALOG OUTPUT INVERTER

The object of this paper is to apply arbitrary unidirectional voltage to the load. Therefore some special circuit and special control algorithm are needed. Fig. 3 shows the proposed analog voltage output inverter. In this circuit, switch S_1 is charging switch, S_2 is discharging switch. R_L and C_L are R-L load. R_b is voltage feedback resistor.

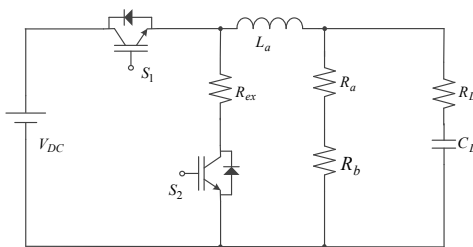

Fig. 3 Proposed analog voltage output inverter

When switch S_1 is on and S_2 is off, the load current flows from the voltage source to the load through L_a . Because of L_a , inrush current doesn't flow to the load and the load voltage becomes to increase slowly compared with Fig. 2. If the switch S_1 turns off, the output voltage becomes constant because there are no pass for the current to flow except for the feedback resistors. The value of feedback resistors are very big, the current becomes almost 0. If the increasing rate of the voltage needs to be controlled, the duty of the switch S_1 should be adjusted. If the load voltage needs to be decreased, S_1 becomes to turn off and S_2 begins to act. If S_2 is turn on, the charged energy in the load is discharged through the discharging resistor R_{ex} . The load voltage is controlled according to the command voltage. The load voltage is measured by the feedback resistor R_b . The total scheme of this control is shown as Fig. 4.

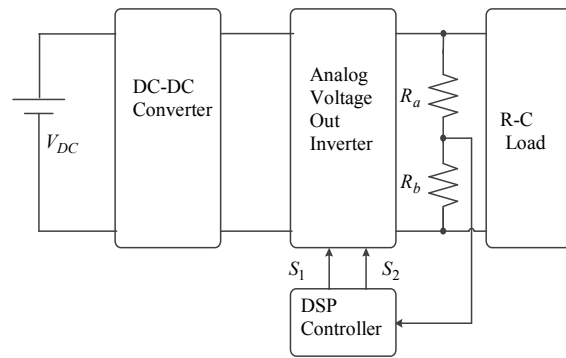

Fig. 4 The full system block for arbitrary applied voltage to R-C load

The source voltage V_{DC} is applied to the DC-DC boost converter and the output voltage of the DC-DC converter is applied to the analog voltage out inverter. The operating scheme is explained above. Although the inductor L_a reduces the increasing or decreasing rate of the flowing current, the current needs to be controlled to adjust the output voltage exactly. To control the output voltage accurately, high speed controller is needed. In this paper, DSP (TMS320F28335) is used as the digital controller of the analog voltage output inverter and this is also expressed in Fig. 4. With the feedback voltage V_{feed} , the switching signals S_1 and S_2 are generated.

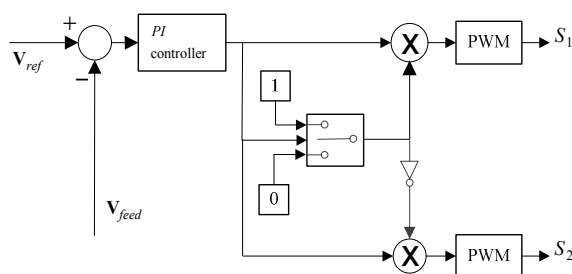

Fig. 5 Control scheme for the proposed inverter

Fig. 5 shows the proposed control scheme for the analog voltage output inverter. The feedback voltage V_{feed} is compared with the reference voltage V_{ref} and the error $V_{ref} - V_{feed}$ becomes the input of the PI controller. The output of the PI controller may have positive or negative values. If the output of the PI controller is positive, it means the load voltage needs to be increased. Therefore the charging switch S_1 needs to be actuated to increase the output load voltage. On the contrary, if the output of the PI controller is negative, the output load voltage is greater than the reference voltage and needs to be decreased. In this case, switch S_2 becomes to operate to discharge the energy in the capacitor load and the output load voltage begins to decrease. Because the output of the PI controller is negative when switch S_2 operates, -1 is multiplied to the value to make it positive. When one switch operates, the other switch should not be on. It is realized by using inverter to make only one switch operate. This calculated positive values become the input of the PWM controller. The each two PWM controllers generate S_1 and S_2 signal to operate the switches in the inverter. Because the load current varies very fast, the carrier frequency needs to be high.

IV. SIMULATION AND EXPERIMENT

A. Simulations

The proposed analog voltage output inverter is simulated including DSP TMS320F28335 as the switching controller for this circuit. This system is configured as Fig. 4.

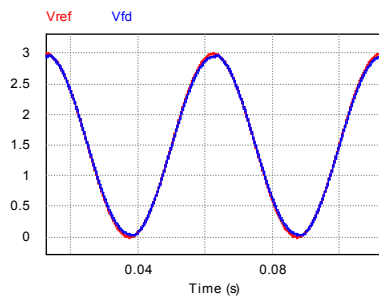

(a) Output voltage (Red : reference, blue : feedback)

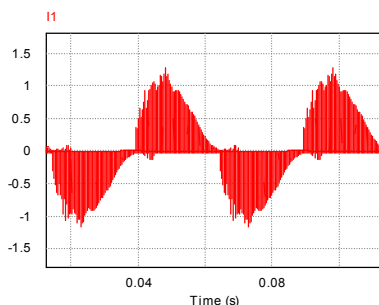

(b) Load current wave form

Fig. 6 Simulation results for load output voltage and current (20Hz)

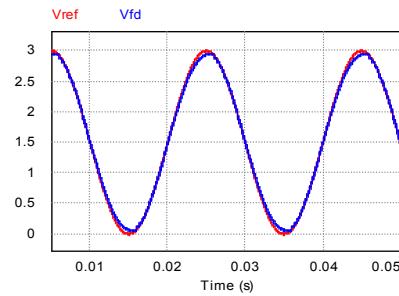

Fig. 7 Simulation results for the load output voltage (50Hz)

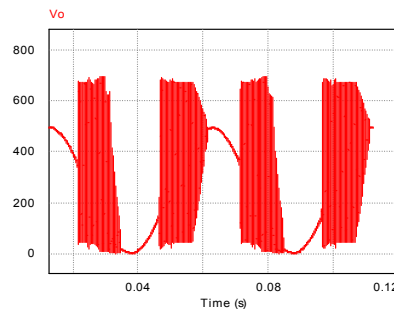

Fig. 8 Simulation results for the load output voltage (50Hz)

The resonant frequency between inductance L_a load capacitor C_L can make some effect in controlling this inverter according to their values, so the carrier frequency can be important. In this case, the switching frequency is 80 (kHz) for accurate current and output voltage control considering resonance frequency.

Figs. 6 and 7 show the simulation results of the proposed inverter including control algorithm for the output load voltage. The reference voltage in Fig. 6 (a) is 150 (V), 20 (Hz) sinusoidal wave. The blue line shows the feedback voltage and it follows the reference voltage very well only with small difference. The P and I gain are very important not only for the performance of the inverter but for the convergence of the controller. Therefore the values of P and I need to be determined with care. Fig. 6 (b) shows the load current waveform. In the figure, current varies with high frequency to match the output voltage waveform with reference wave because the current time constant is very small and the current varies with sharp slope. Fig. 7 shows the reference and feedback voltage waveforms for 150 (V), 50 (Hz) sinusoidal wave. Fig. 8 shows the failed case when the P gain is not appropriate and the control result for the load voltage is no more converged.

B. Experiments

Fig. 9 shows the implemented system for analog voltage output inverter. This system includes DSP control board, 150 (V), 200 (VA) DC-DC converter, R-C load and the analog voltage output inverter. This system is already explained in section III. The DSP is TMS320F28335 and R-C load has 60(Ω) resistor and 1(μ F) capacitor.

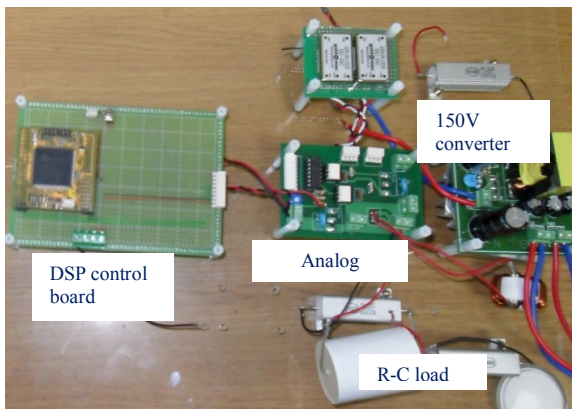
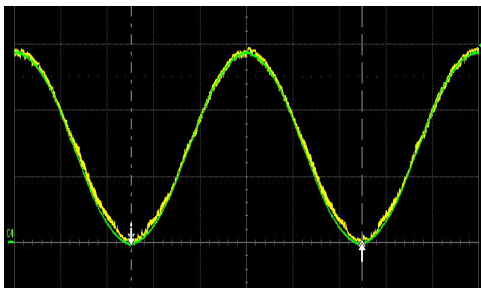

Fig. 9 The implemented system for analog voltage output inverter

In this case, the input DC voltage of the inverter is 150 (V). If the input voltage is much higher than this case, switching noise can affect DSP, switching signals etc., and the isolation between signal part and power part becomes significant. Especially the feedback part of the load voltage needs to be isolated for safe and stable operation.

Fig. 10 shows the experimental results of the load output voltage when the reference voltage wave form is sinusoidal. Fig. 10 (a) shows the same case of Fig. 6 (a). Fig. 10 (b) is the same case of Fig. 7. The base frequency of the reference voltage wave in Fig. 10 (a) is 20 (Hz) and that in Fig. 10 (b) is 50 (Hz). As the base frequency increases, the delay angle increases because the digital control system has same delay time. If the delay angle is important parameter, this needs to be considered for the accuracy of the object system.



(a) Output voltage (green: reference, yellow: feedback, 20(Hz))

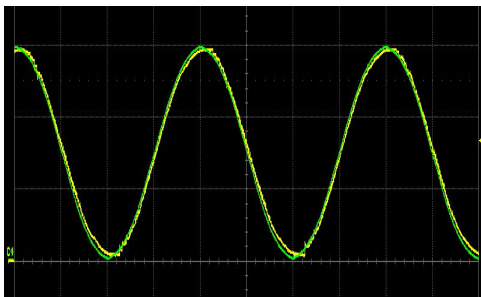

(b) Output voltage (green: reference, yellow: feedback, 50(Hz))

Fig. 10 Experimental results for the load output voltage

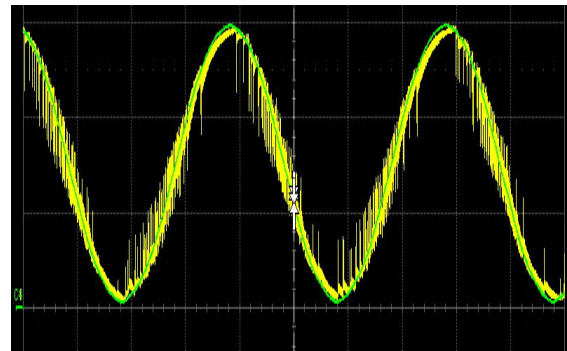

Fig. 11 Output voltage waveform for 30(kHz) switching frequency

As mentioned before, the switching carrier frequency is also important according to the inductance and capacitance value. Fig. 11 shows an example when the switching frequency is not appropriate. In this case, the base frequency is 50 (Hz) and the switching frequency is 30 (kHz), and the result looks to have serious noise.

V. CONCLUSIONS

Piezoelectric load is considered as R-C load and its voltage does not decrease even though the applied voltage decreases. For driving R-C load or piezoelectric actuator with unidirectional arbitrary voltage, special driving circuit and algorithm is required. In this paper, a simple special inverter with a circuit that can discharge the capacitive energy is proposed as well as a simple control algorithm for unidirectional arbitrary voltage driving. The proposed simple inverter can charge and discharge the energy of R-C load with unidirectional arbitrary voltage. To complete the operation, digital control scheme with DSP is combined with the inverter to apply the switching signal to the inverter switches. With the proposed simple circuit, the load voltage can have any unidirectional level with tens of bandwidth because the load voltage can be adjusted by switching the charging and discharging switch appropriately. The appropriateness is proved with the simulation and experiments of the proposed circuit.

REFERENCES

- [1] Feel-soon Kang, "AC-PDP Sustain Driver using Bidirectional Switches", *JEET* Vol.6, No.1, pp.86-93, 2011.
- [2] S.C.Lee, S.Y.Soh, J.W.Seo and B.K.Kang, "Versatile energy recovery circuit for driving AC plasma display panel with single sustain circuit board", *Displays*, Volume 27, Issues 4-5, pp.153-160, Nov. 2006.
- [3] F. S. Kang, S. J. Park, J. H. Cho, W. S. Yoon, C. U. Kim, "High-Performance Sustain Driver for Plasma Display," *IEEE Trans. Ind. Electron.*, Vol. 53, No. 4, pp. 1322-1327, Aug., 2006.
- [4] Sun-Ki Hong, Jung-Seop Lee, Nam-HeeByeon, Tae-Sam Kang, Jeong Hoi Gu, "Energy Recovery Circuit and Asymmetric Voltage Driving Circuit for Piezoelectric Elements," The 7th World Congress on Biomimetics, Artificial Muscles and Nano-Bio (BAMN2013), August 26-30, 2013, Jeju Island, South Korea.
- [5] Sun-Ki Hong, Jung-Seop Lee, Nam-HeeByeon, Taesam Kang, "A Study of Unidirectional Driving Circuit of Piezoelectric Device Considering Energy Recovery," *Applied Mechanics and Materials*, Vol. 490-491, pp.1053-1056, 2014.