

A Study of the Relation of Wave Height and Erosion at Bangkhuntien Shoreline, Thailand

Prasertsak Ekphisutsuntorn*, Prungchan Wongwises, Chaiyuth Chinnarasri,
Usa Humphries and Suphat Vongvisessomjai

Abstract—In this paper, the significant wave height at the Upper Gulf of Thailand and the changing of wave height at Bangkhuntien shoreline were simulated by using the Simulating WAVes Nearshore Model (SWAN) version 40.51. The simulated results indicated that the significant wave height by SWAN model corresponded with the observed data. The results showed that the maximum significant wave height at the Bangkhuntien shoreline were 1.06-2.05 m. and the average significant wave height at the Bangkhuntien shoreline were 0.30-0.47 m. The significant wave height can be used to calculate the erosion through the Bangkhuntien shoreline.

The erosion rates at the Bangkhuntien shoreline were prepared by using the aerial photo and they were about 1.80 m/yr. from 1980-1986, 4.75 m/yr from 1987-1993, 15.28 m/yr from 1994-1996 and 10.03 m/yr from 1997-2002. The relation between the wave energy and the erosion were in good agreement. Therefore, the significant wave height was one of the major factors of the erosion at the Bangkhuntien shoreline.

Keywords—significant wave height, erosion, SWAN, relation, Bangkhuntien shoreline

I. INTRODUCTION

THE Bangkhuntien district is a district of the Bangkok Municipality under the authority of the Governor of Bangkok [1]. The Bangkhuntien shoreline is the only muddy shoreline in the Bangkhuntien district [1], [2], [12], [13]. This shoreline is located in the Upper Gulf of Thailand [1], [2]. There are four river mouths in the Upper Gulf of Thailand: the Mae Klong, the Tha Chin, the Chao Phraya and the Bang Pakong. This is illustrated in Fig. 1. This shoreline is a part of a muddy coastline with mangrove forests. The length of this shoreline is about 5 km [11], [12], [13], [14]. In the past, this coastline was a real inter-tidal area with plenty of mangrove bushes being subject to flooding and allowing the delta to maintain a dynamic equilibrium. Its coastline could, at times, be eroded but was built up again, depending on the sediment load and the governing hydraulic conditions [10], [11], [15]. The Bangkhuntien coastal zone was degraded and loss of land occurred due to the eroding forces of the sea. The sediment supply decreased from the river and the attacking of wave and current seem to be the major factors causing the shoreline

The authors would like to acknowledge the Joint Graduate School of Energy and Environment, King Mongkut's University of Technology Thonburi for giving financial support to Mr. Prasertsak Ekphisutsuntorn

*Corresponding author, Email: actwater7@hotmail.com

Tel: +66 2470 8309-10 Fax: +66 28726736

erosion in this area [1], [11].

Therefore, in this paper the wave characteristics from 1981 to 2004 in this area will be simulated by SWAN cycle III version 40.51[18] model and compared with the erosion rate which was prepared by the aerial photographs.

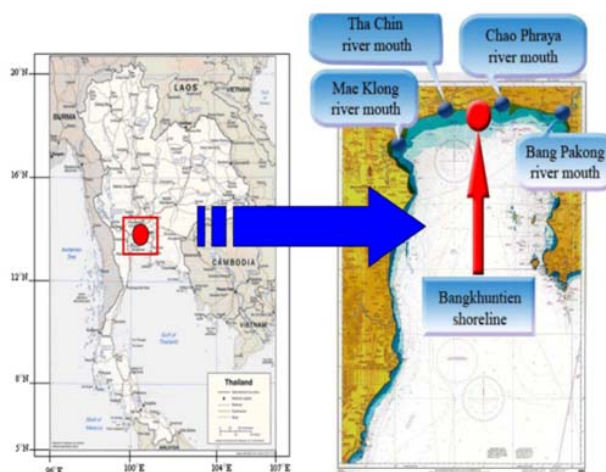

Fig. 1 Map of Thailand and the location of the Bangkhuntien shoreline.

II. METHODOLOGY

The significant wave height at the Upper Gulf of Thailand and the Bangkhuntien shoreline must be properly understood by investigating the wave forces on the shoreline. A knowledge of the waves generated by wind and the sediment transport by wave height is very useful in studying shoreline erosion in this area.

Therefore, the wave characteristics from 1981 to 2004 in this area will be simulated by SWAN cycle III version 40.51 [4], [5], [9], [14], [18], [19], [20] model and compared with the erosion rate which was prepared by the aerial photographs

III. MODEL DESCRIPTION

The SWAN model was developed by Delft University of Technology [4], [5], [9], [14], [18], [19], [20] and is free for the public domain. It is used by many government authorities, research institutes and consultants worldwide. The feedback has widely indicated the reliability of SWAN in different

experiment and field cases. It is widely used for nearshore wave forecasting around the world.

Based on the wave action balance equation with sources and sinks, the shallow water wave model SWAN (acronym for Simulating WAVes Nearshore) is an extension of the deep water third-generation wave models. It incorporates the state-of-the-art formulations for the deep water processes of wave generation, dissipation and the quadruplet wave-wave interactions from the WAM model [3], [5], [7]. In shallow water, these processes have been supplemented with the formulations for dissipation due to bottom friction, triad wave-wave interactions and depth-induced breaking. SWAN is fully spectral (in all directions and frequencies) and computes the evolution of wind waves in coastal regions with shallow water and ambient current.

Wind-generated waves have irregular wave heights and periods, caused by the irregular nature of wind. The sea surface elevation, in one point as a function of time, can be described as;

$$\eta(t) = \sum_i a_i \cos(\sigma_i t + \alpha_i) \quad (1)$$

when η is the sea surface elevation, a_i is the amplitude of the i^{th} wave component, σ_i is the relative radian or circular frequency of the i^{th} wave component in the presence of the ambient current (equal to the absolute radian frequency ω , when no ambient current is present) and α_i the random phase of the i^{th} wave component. This is called the random-phase model.

The total energy density at a frequency f is distributed over the directions θ in $E(f, \theta)$, it follows that;

$$E(f) = \int_0^{2\pi} E(f, \theta) d\theta \quad (2)$$

Based on the energy density spectrum, the integral wave parameters can be obtained. These parameters can be expressed in terms of the so-called n -th moment of the energy density spectrum;

$$m_n = \int_0^{\infty} f^n E(f) df \quad (3)$$

The total energy of a wave system is the sum of its kinetic energy and its potential energy. The kinetic energy is that part of the total energy. The kinetic energy per unit length of wave crest for a linear wave can be found from

$$\bar{E}_k = \frac{1}{16} \rho g H^2 L \quad (4)$$

The potential energy per unit length of wave crest for a linear wave is given by

$$\bar{E}_p = \frac{1}{16} \rho g H^2 L \quad (5)$$

According to the Airy theory, the total wave energy in one wave length per unit crest width is given by

$$E = E_p + E_k = \frac{\rho g H^2 L}{8} \quad (6)$$

Total average wave energy per unit surface area, termed the specific energy or energy density, is given by

$$\bar{E} = \frac{E}{L} = \frac{\rho g H^2}{8} \quad (7)$$

where H is the significant wave height, ρ is the specific gravity of sea water and g is gravity acceleration.

In this paper SWAN cycle III version 40.51, supported by Rijkswaterstaat (as part of the Ministry of Transport, Public Works and Water Management, The Netherlands) was used. The SWAN model [9], [16], [17] was used to solve the wave variance spectrum or energy density, wave energy over frequencies and propagation directions.

A. Study domain

The study domain covered is 99° E to 101° E in longitude and 12° N to 14° N in latitude with resolution of $2.4 \text{ km} \times 2.4 \text{ km}$ as shown in Fig. 2. The study area covers the Bangkhuntien shoreline.

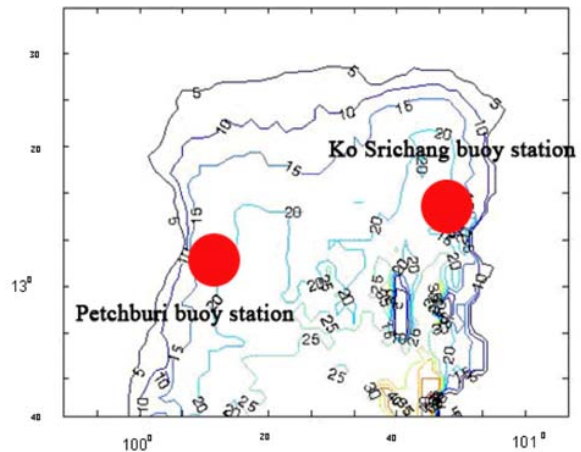
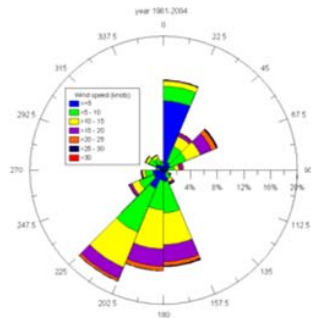

Fig. 2 The bathymetry map of the Upper Gulf of Thailand.

B. Data collection

The Bathymetry data (1:240,000) at the Upper Gulf of Thailand are taken from The Hydrological Department of the Royal Thai Navy, wind data (10 m. height) of every 3 hours at Pilot station are taken from the Thai Meteorological Department (TMD) and the observed significant wave height at Petchburi buoy and Ko Srichang buoy (as shown in Fig. 1) are taken from the Geo-Informatics and Space Technology Development Agency (Public Organization) (GISTDA).

Fig. 3 shows the wind rose diagram (Pilot station) during 1981 to 2004. These wind data were used to generate the significant wave height. The wind field was uniformed along the shoreline with speeds at approximately 5 knots. Generally, the wave fields responded very well with the wind pattern.



Year 1981-2004

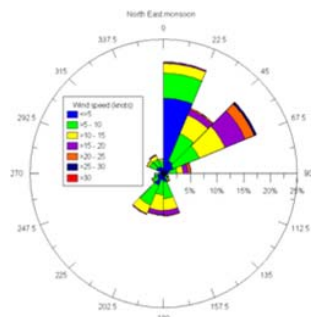

NE Monsoon

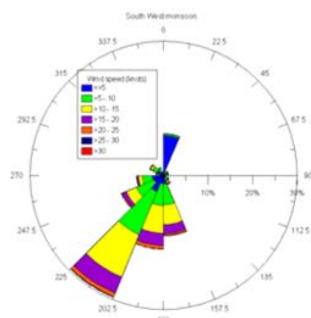

SW Monsoon

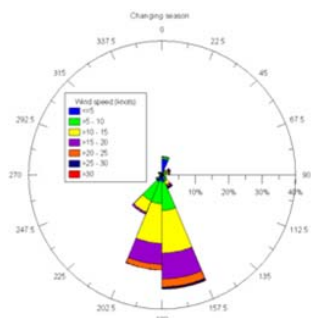

Changing Season

Fig. 3 Wind rose diagram at Pilot station.

C. Model performance

The simulate performance is evaluated using a goodness of fit measures, namely the correlation coefficient (CC):

$$CC = \frac{\sum_{i=1}^n [(H_o)_i - (\overline{H_o})][(H_m)_i - (\overline{H_m})]}{\sqrt{\sum_{i=1}^n [(H_o)_i - (\overline{H_o})]^2} \sqrt{\sum_{i=1}^n [(H_m)_i - (\overline{H_m})]^2}} \quad (8)$$

where H is the significant wave height, the subscripts 'o' and 'm' represent the observed and model simulated value respectively.

D. Model verification

The SWAN (Shallow water Wave Nearshore) model has been verified with the buoy observations data (significant wave heights) in 1996 and 1998 at Petchburi station and Ko Srichang station respectively. Fig. 4 a) shows the calibration result at Petchburi in 1996. Fig. 4 b) shows the calibration result at Ko Srichang in 1996. Fig. 5 a) shows the verification result at Petchburi in 1998. Fig. 5 b) shows the verification result at Ko Srichang in 1998. The solid red line represents the simulated result and the dashed blue line represents the observed significant wave height. Fig. 6 a) shows the correlation between the observed significant wave heights and the simulated significant wave heights from the model at Petchburi station in 1996. Fig. 6 b) shows the correlation between the observed significant wave heights at Ko Srichang station and the simulated significant wave heights from the model in 1996.

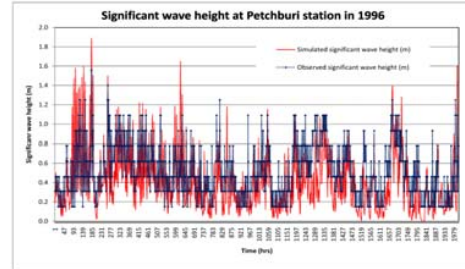

a) Petchburi station

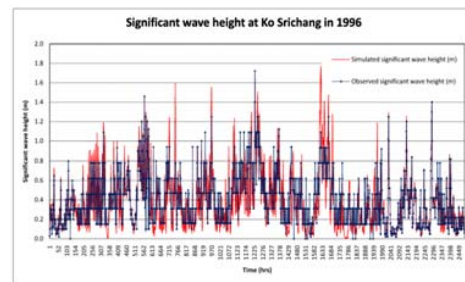

b) Ko Srichang station

Fig. 4 Verification results at Petchburi station and Ko Srichang station in 1996.

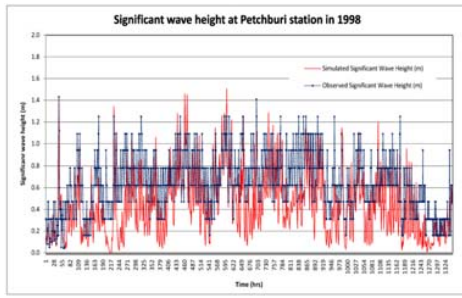

a) Petchburi station

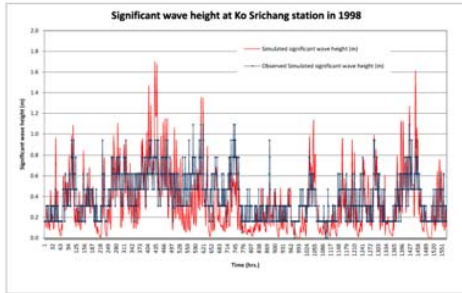

b) Ko Srichang station

Fig. 5 Verification results at Petchburi station and Ko Srichang station in 1998.

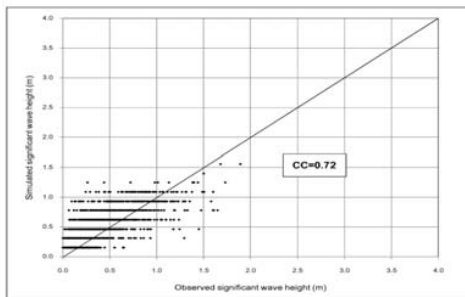

a) Petchburi station

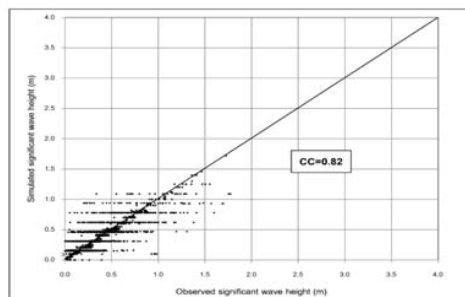

b) Ko Srichang station

Fig. 6 Correlation between the observed significant wave heights and the simulated significant wave height in 1996.

The correlation coefficient (CC) at Petchburi station and Ko Srichang station are 0.72 and 0.82 respectively. Fig. 7 a) shows the correlation between the observed significant wave heights at Petchburi station and the simulated significant wave heights from the model in 1996. Fig. 7 b) shows the correlation between the observed significant wave heights and the simulated significant wave heights at Ko Srichang station from the model in 1998. The correlation coefficient (CC) at Petchburi station and Ko Srichang station in 1998 are the same as 0.72. The comparison of the observed significant wave height at the buoy stations and the simulated significant wave heights (H_s) shows that the simulation are correspond with the observation.

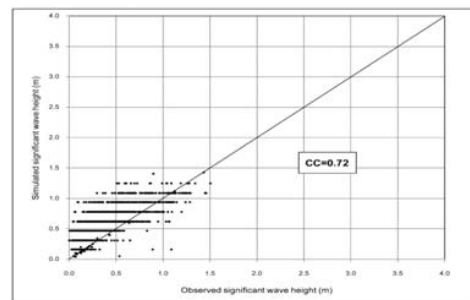

a) Petchburi station

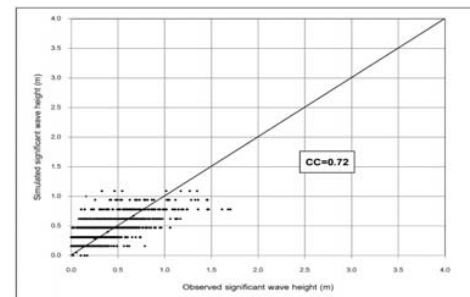

b) Ko Srichang station

Fig. 7 Correlation of the observed significant wave heights and the simulated significant wave heights in 1998.

E. Model simulation

The SWAN model simulated the significant wave height from 1981 to 2004 (1982-1983 are not have the data record) at the Upper Gulf of Thailand.

F. Erosion rate

The Erosion rate was prepared by using aerial photos. The aerial photos were taken from 1980 to 2002. We generated the trend of the shoreline and read the erosion rate at every 50 meters. The shoreline is about 5 kilometers. We could summarize the average erosion rate at the shoreline in the every year by the aerial photos and used this information to prepare with the significant wave height.

IV. RESULTS AND DISCUSSION

A. Significant wave height at the Upper Gulf of Thailand

The application of a two-dimensional model based on the Simulating Waves Nearshore Model (SWAN) to predict the significant wave height at the Upper Gulf of Thailand has been described. The predicted result was in good agreement with the observed significant wave height. The significant wave height at the Upper Gulf of Thailand could be simulated.

The results from SWAN model showed that the SWAN model can be used to simulate the significant wave height at the Upper Gulf of Thailand.

Fig. 8 shows the observed wind fields and the simulated significant wave height at 21:00 UTC, on 15th December 1998 (NE Monsoon). a) Influenced by the Northeast monsoon, the wind blew from Northeast to Southwest and the average wind speed was about 10.81 m/s and b) The significant wave height was about 0.2 m, near the sea shore, and there was increasing wave height far away from the sea shore according to the accumulated wind energy. The size of the significant wave height was shown by a contour line and the vector with arrows represents the significant wave direction. Fig. 9 shows the observed wind fields and the simulated significant wave height at 21:00 UTC, on 1st March 1998. a) Influenced by the Southwest monsoon, the wind blew from South to North, and the average wind speed was about 12.87 m/s and b) The significant wave height was about 0.8 m, far away from the shoreline, there was an increase in wave height at the shore according to the accumulated wind energy from the deep sea. The size of the significant wave height was shown by a contour line, and the vector with arrows represents the significant wave direction. Fig. 10 shows the observed wind fields and the simulated significant wave height at 21:00 UTC, on 15th September 1998. a) Influenced by Southwest monsoon, the wind blew from South to North and the average wind speed was about 8.24 m/s and b) the significant wave height was about 0.4 m from the shore and there was increasing wave height on the seashore according to the accumulated wind energy from the deep sea far away from the shoreline, and there was increasing to a wave height on the seashore, according to the accumulated wind energy from the deep sea. The size of the significant wave height was shown by a contour line and the vector with arrows represents the significant wave direction.

B. Significant wave height at the Bangkhuntien shoreline

The application of a two dimensional model based on the (SWAN) predicted the significant wave height at the Bangkhuntien shoreline by using the 3 hour wind speed at Pilot station. The significant wave height at Bangkhuntien shoreline has been described and the significant wave height at Bangkhuntien shoreline is shown in Fig. 11.

C. The erosion rate at the Bangkhuntien shoreline

The erosion rate at the Bangkhuntien shoreline was prepared by using aerial photos from 1980 to 2002. The shoreline was divided in every 50 meters. The erosion rate was compared with the Bangkok border pole in the sea. The aerial photos were shown in Fig. 12-14 and the trend lines of the shoreline were shown in Fig. 15.

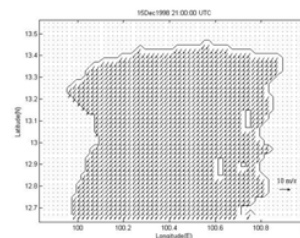

a) Observed wind field vector

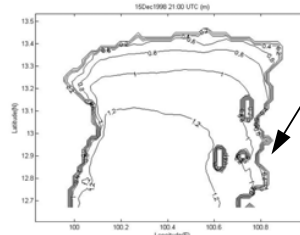

b) Simulated significant wave height and simulated significant wave height vector at sea surface

Fig. 8 The simulated significant wave height at the surface elevation (a) shows the observed wind data and (b) shows the simulated significant wave height at sea surface, from the model on 15th December 1998 21:00 UTC (NE Monsoon).

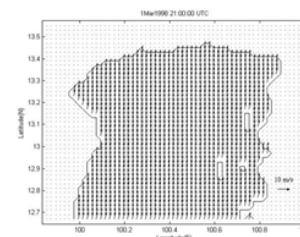

a) Observed wind field vector

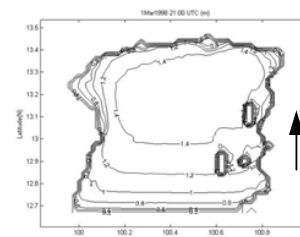

b) Simulated significant wave height and simulated significant wave height vector at sea surface

Fig. 9 The simulated significant wave height at the surface elevation (a) shows the observed wind data and (b) shows the simulated significant wave height at sea surface, from the model on 1st March 1998 21:00 UTC (Changing Season).

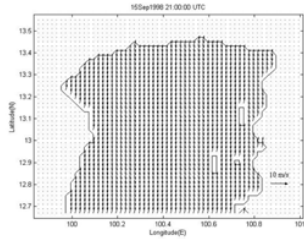

a) Observed wind field vector

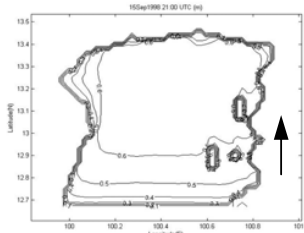

b) Simulated significant wave height and simulated significant wave height vector at sea surface

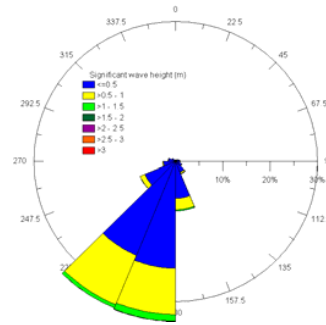

c) SW monsoon

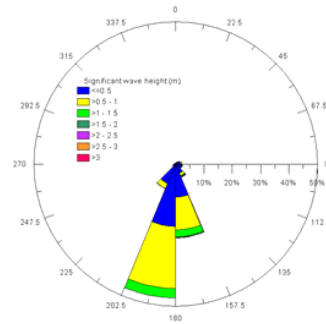

d) Changing season

Fig. 10 The simulated significant wave height at the surface elevation (a) shows the observed wind data and (b) shows the simulated significant wave height at sea surface, from the model on 15th September 1998 21:00 UTC (SE Monsoon).

Fig. 11 Significant wave height (m) at Bangkhuntien Shoreline.

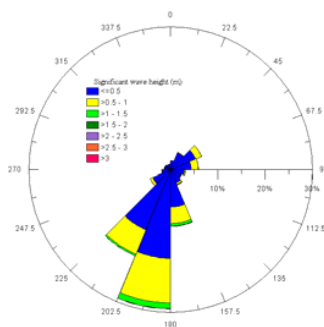

a) Year 1981-2004

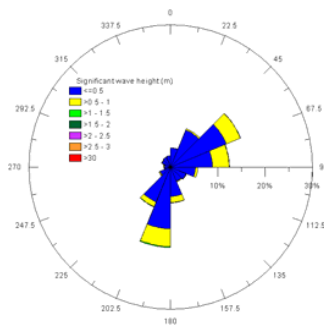

b) NE monsoon

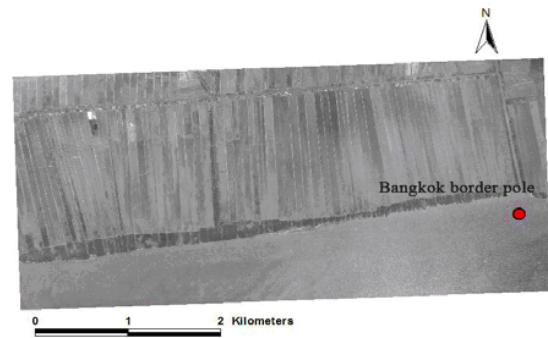

Fig. 12 The aerial photo at Bangkhuntien shoreline on 1980.

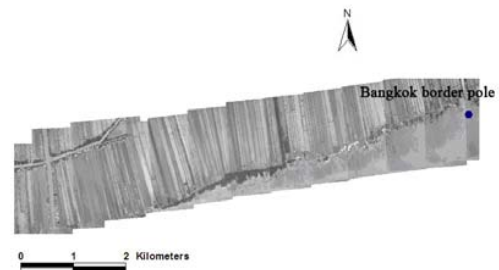

Fig. 13 The aerial photo at Bangkhuntien shoreline on 1993.

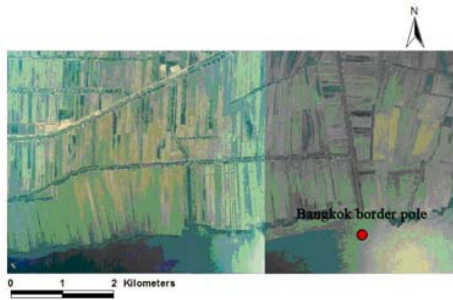

Fig. 14 The aerial photo at Bangkhuntien shoreline on 2002.

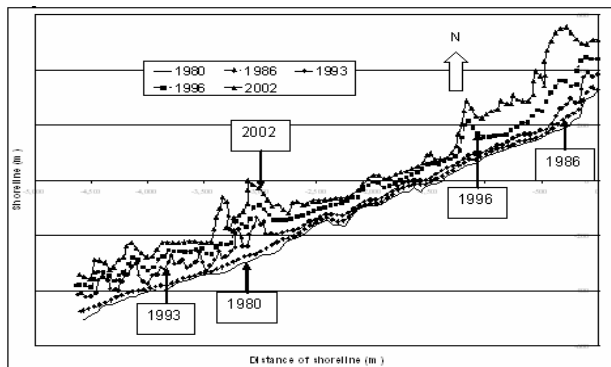

Fig. 15 The trend lines of erosion at Bangkhuntien shoreline.

V. CONCLUSIONS

A. Assumptions

Sediment transport is the major cause of shoreline erosion. Sediment moved by waves was divided into cross shore and longshore sediment transport. Sediment movement causes the erosion or accretion [6], [11]. Erosion normally results in shoreline recession and accretion causes the sediment move out to the sea [6] as shown in Fig. 16.

The cross shore sediment transport occur when wave come further to the shore and attack the foot of the coastline causing them to become unstable and the particle move in the cross shore direction [6].

Waves approaching the shore at an angle will cause the alongshore current and move sediment along and cross the shore in the direction of wave propagation. The wave pushes sand or particles up the coastline in the wave direction and move in the alongshore direction. When the wave retreats, the particles are accelerated by gravity and travel down to the coastline [6].

B. Significant Wave Height at Bangkhuntien shoreline

The attacking wave was the most important indicator of the erosion, especially at Bangkhuntien shoreline. SWAN model can be used to simulate the hourly significant wave height at the Upper Gulf of Thailand and Bangkhuntien shoreline. The simulated results show that the maximum significant wave height at Bangkhuntien shoreline are 1.06-2.05 m. (21 years)

and the average significant wave height are 0.30-0.47 m. (21 years) as shown in Table I.

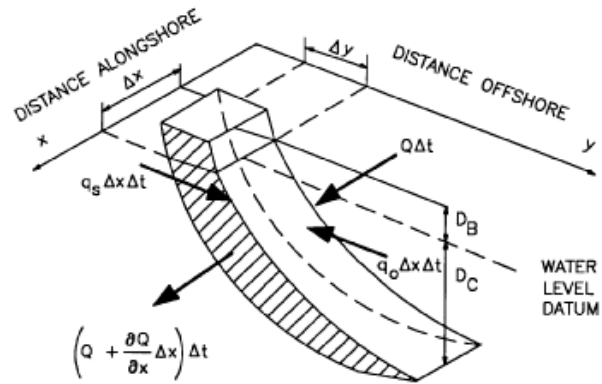

Fig. 16 The sediment transport into cross shore and alongshore sediment transport [8].

C. Erosion rate at Bangkhuntien shoreline

The erosion rate at Bangkhuntien shoreline could be computed by using the aerial photos. The average erosion rate from 1986 to 2002 was about 1.80 m/y to 15.28 m/yr as shown in Table II.

D. The relation of wave energy and the erosion rate at Bangkhuntien shoreline

The relation of wave energy and the average erosion rate at Bangkhuntien shoreline is shown in Fig. 17.

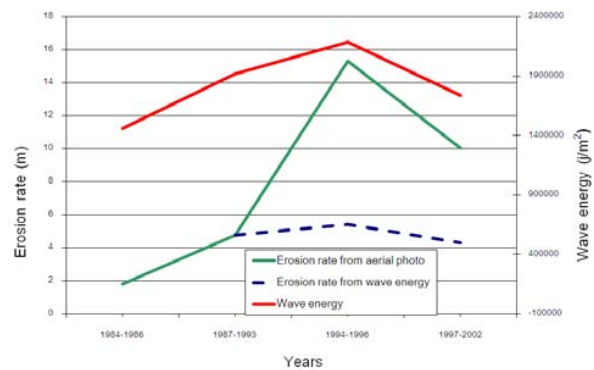

Fig. 17 The relation between wave energy and erosion rate at Bangkhuntien shoreline.

Fig. 17 shows the relation of wave energy and the erosion rate which was observed (aerial photo) and the relation of wave energy and the erosion rate which was calculated by wave energy. In Fig. 17, the red line shows the wave energy from 1984 to 2002 and the green line shows the erosion rate which was observed by using the aerial photos from 1984 to 2002 and the dashed blue line shows the erosion rate was calculated by wave energy from 1984-2002. Fig. 17 shows

that the erosion rate and wave energy may be related and the erosion rate which was observed by using the aerial photos increased over the effect of the wave due to the rapid increase of the shrimp farming business at Bangkhuntien between 1989 to 1992. As the result of this, the mangrove belt was destroyed [1].

VI. RECOMMENDATION

The mechanisms of the erosion and the other factors will be considered. The shoreline erosion must be simulated under the erosion parameters. The fortunated for shoreline erosion, suitable solving and suitable protection will be considered in the future.

ACKNOWLEDGMENTS

This study was supported by the Joint Graduate School of Energy and Environment, King Mongkut's University of Technology Thonburi. Special thanks are offered to the Hydrological Department of the Royal Thai Navy, the Royal Thai Survey Department (RTSD), the SWAN team, Faculty of Civil Engineering and Geosciences Delft University of Technology for SWAN model. Finally, the authors are greatly indebted to Mr. Jonathan David Humphries and Mr. Michael Willing for helpful comments on English grammar and usage.

REFERENCES

- [1] Bangkok Metropolitan Administration, Bangkhunthien pilot project coastal erosion and reclamation study, Ministry of Interior, Thailand, 2001, 75.
- [2] Bangkok Metropolitan Administration, The Bangkhuntien shoreline protection and troubleshooting project, Bangkok, Thailand, 2006, 267.
- [3] G. Komen, L. Cavaleri, M. Donelan, K. Hasselmann, S. Hasselmann and P.A.E.M. Janseen, Dynamics and modelling of ocean waves, Cambridge University Press, UK, 1994, 532.
- [4] J. A. Battjes, M. Isaacson and M. Quick (Eds.), "Shallow water wave modelling," in *1994 Proc. Waves-Physical and Numerical Modelling*, University of British Columbia, Vancouver, pp. 1-24.
- [5] J. C. Hargreaves and J. D. Annan, "Comments on Improvement of the short fetch behavior in the wave ocean model (WAM)," *J. Atmos. Oceanic Techn.*, Vol. 18, 2001, pp.711-715.
- [6] J. W. Kamphuis, Introduction to coastal engineering and management, World Scientific Publishing, Singapore, Vol.16, 2000, 437p.
- [7] H. Gunther, S. Hasselmann and P.A.E.M. Janssen, The WAM model Cycle 4 (revised version), Deutsch. Klim. Rechenzentrum, Techn. Rep. No. 4, Hamburg, Germany, 1992.
- [8] H. Hanson, GENESIS, A generalized shoreline change model for engineering use, Report No. 1007, Department of Water Resources Engineering, University of Lund, Lund, Sweden, 1987.
- [9] K. Hasselmann, T. P. Barnett, E. Bouws, H. Carlson, D.E. Cartwright, K. Enke, J. A. Ewing, H. Gienapp, D. E. Hasselmann, P. Kruseman, A. Meerburg, P. Muller, D. J. Olbers, K. Richter, W. Sell and H. Walden, Measurements of wind-wave growth and swell decay during the Joint North Sea Wave Project (JONSWAP), *Dtsch. Hydrogr. Z. Suppl.*, 12, A8, 1973, 95.
- [10] K. Horikawa, M. Hattori, "The nearshore environment research center project," *Proc. Coastal Sediments, American Society of Civil Engineers*, 1987, pp. 756-771.
- [11] N. L. Jackson, "Evaluation of criteria for predicting erosion and accretion on an estuarine sand beach, Delaware bay, New Jersey," *J. Estuaries Coast.*, Vol. 22[2A], 1999, pp. 215-223.
- [12] P. Ekphitsuntorn, The study of wave and current influences on shoreline changes at Bangkhuntien district, King Mongkut's University of Technology Thonburi, Bangkok, Thailand, 2001.
- [13] P. Ekphitsuntorn, Numerical modeling of erosion at Bangkhuntien district, Thailand, King Mongkut's University of Technology Thonburi, Bangkok, Thailand, 2008.
- [14] P. Ekphitsuntorn, P. Wongwises, C. Chinnarasri, U. W. Humphries and S. Vongvisessomjai, "Numerical Modeling of Erosion for Muddy Coast at Bangkhuntien shoreline, Thailand," *J. Environ Sci Eng.*, Vol.2[4], 2010, pp. 230-240.
- [15] Royal Forest Department, The feasibility study on mangrove revival and extension project in the Kingdom of Thailand, Ministry of Agriculture and Cooperatives, Thailand, 2001.
- [16] S. Hasselmann, K. Hasselmann, E. Bauer, P.A.E.M. Janssen, G. J. Komen, L. Bertotti, P. Lionello, A. Guillaume, V. C. Cardone, J. A. Greenwood, M. Reistad, L. Zambresky and J. A. Ewing, "The WAM model—a third generation ocean wave prediction model," *J. Phys Ocean.*, Vol. 18, 1988, pp. 1775–1810.
- [17] S. Hasselmann, K. Hasselmann, J. H. Allender and T. P. Barnett, "Computations and parameterizations of the nonlinear energy transfer in a gravity–wave spectrum, Part II: Parameterizations of the nonlinear energy transfer for application in wave models," *J. Phys Ocean.*, Vol. 15, 1985, pp. 1378–1391.
- [18] The SWAN team, SWAN technical documentation, Environmental Fluid Mechanics Section, Faculty of Civil Engineering and Geosciences, Delft University of Technology, The Netherlands, 2006, 66.
- [19] W. Wannawong, U. W. Humphries, P. Wongwises, S. Vongvisessomjai and W. Lueangaram, "Numerical Analysis of Wave and Hydrodynamic Models for Energy Balance and Primitive Equations," *J. Math Stat Sci.*, Vol. 2[4], 2010, pp. 140-150.
- [20] W. Wannawong, U. W. Humphries, P. Wongwises, S. Vongvisessomjai, "Three Steps of One-way Nested Grid for Energy Balance Equations by Wave Model," *J. comp Math Sci.*, Vol. 5[1], 2011, pp.23-30.

Prasertsak Ekphisutsumorn received the B.Eng. degree in water resources engineering from Kasetsart University, Bangkok, Thailand, in 1992, the M.Eng. in water resources engineering from King Mongkut's University of Technology Thonburi (KMUTT), Bangkok, Thailand, in 1999 and Ph.D. degrees in environmental technology from The joint graduate school of energy and environment, King Mongkut's University of Technology Thonburi (KMUTT), Bangkok, Thailand, in 2010, respectively. He was with the Numerical Weather Prediction Center, Hydrographic Department, Royal Thai Navy from 2008 to 2009. He joined the Oceanography Modeling team at IAP (Institute of Atmospheric Physics), Chinese Academy of Sciences, P.R. China, in April 2008. In 2009, a part of his work was advised by Prof. Zhu Jiang from the Institute of Atmospheric Physics (IAP). In December 2009, he joined the workshop of the climate change project at KMUTT and Prof. Zhu Jiang from the Institute of Atmospheric Physics (IAP gave him many ideas to modify the wave and erosion model by adjusting the drag coefficient and the characteristics of the sediment transport. His research interests involve numerical analysis, numerical wave and erosion prediction, computational mathematics, and mathematical modeling.
Email: actwater7@hotmail.com

Prungchan Wongwises received the B.Sc. (Second Honor) degree in mathematics from Chulalongkorn University, Bangkok, Thailand, in 1962, and the Diplom. Math. and Dr. rer.nat. degrees in mathematics from Technical University of Karlsruhe, Germany, in 1969 and 1974, respectively. She got the scholarships from the Technical University of Karlsruhe (Deutscher Akademischer Austauschdienst, DAAD), University of Freiburg, University of Kassel and University of Hannover under the German Government from 1966 to 1993. She currently is an Associate Professor with the Joint Graduate School of Energy and Environment, KMUTT. Her research interests include numerical analysis, computational mathematics, atmospheric modeling, oceanic modeling and air pollution modeling.
Email: prungchan.won@kmutt.ac.th

Chaiyuth Chinnarasri received the B.Eng. degree in civil engineering from King Mongkut's University of Technology Thonburi (KMUTT), Bangkok, Thailand, in 1985, the M.Eng. degree in water resources engineering from Asin Institute of Technology (AIT), in 1990, and the Ph.D. degree in integrated water resources management from Asin Institute of Technology (AIT), in 2000. He was a lecturer in the Division of Water Resources Engineering, Mongkut's University of Technology Thonburi (KMUTT), Bangkok, Thailand. His research interests include river engineering, water resources management, coastal engineering, oceanography, numerical analysis, computational mathematics, oceanic modeling and climate change.
Email: chaiyuth.chi@kmutt.ac.th

Usa W. Humphries received the B.Sc. degree in mathematics from Prince of Songkla University, Songkla, Thailand, in 1991, the M.Sc. degree in applied mathematics from KMUTT, in 1994, and the Ph.D. degree in applied mathematics from University of Exeter, England, in 2000. She was a National Research Council Postdoctoral Investigator with the James Rennell Division University of Southampton, Southampton, England, from November 2001 to December 2002 and with the IAP, China, from October 10 to November 10, 2005. She currently is an Associate Professor with the Department of Mathematics, KMUTT. Her research interests include numerical analysis, computational mathematics, oceanic modeling and climate change.
Email: usa.wan@kmutt.ac.th

Suphat Vongvisessomjai is a Professor of Hydraulic and Coastal Engineering with the Water and Environment Expert, TEAM Consulting Engineering and Management Co., Ltd., Thailand. He was a lecturer in the Division of Water Resources Engineering, Asian Institute of Technology (AIT), Thailand, from 1968 to present and a project engineer in the Delft Hydraulics Laboratory, Netherlands, in 1980. He currently is a Professor and Director of Regional Environmental Management Center, Thailand. His research interests include drainage and flood control, coastal erosion and pollution, and water resources.
Email: suphat@team.co.th

TABLE I
SUMMARY OF THE SIGNIFICANT WAVE HEIGHT AT BANGKHUNTEN SHORELINE

Year	1981	1984	1985	1986	Average
Maximum	2.05	1.06	1.94	1.67	1.68
Significant wave height (m)					
Average	0.47	0.3	0.39	0.36	0.38
Significant wave height (m)					
Wave energy (J/m^2)	2,829,934.28	1,021,571.39	1,861,829.99	1,496,016.67	1,802,338.08

Year	1987	1988	1989	1990	1991	1992	1993	Average
Maximum	1.97	1.5	1.3	1.52	1.71	1.93	1.37	1.61
Significant wave height (m)								
Average	0.4	0.32	0.33	0.41	0.47	0.45	0.4	0.40
Significant wave height (m)								
Wave energy (J/m^2)	1,894,738.25	1,183,625.98	1,269,062.73	2,078,888.05	2,597,655.62	2,448,982.94	1,949,805.22	1,917,536.97

Year	1994	1995	1996	Average
Maximum	1.65	1.43	1.44	1.51
Significant wave height (m)				
Average	0.43	0.44	0.4	0.42
Significant wave height (m)				
Wave energy (J/m^2)	2,171,243.99	2,567,708.86	1,821,236.41	2,186,729.75

Year	1997	1998	1999	2000	2001	2002	Average
Maximum	1.6	1.43	1.48	1.58	1.53	1.55	1.53
Significant wave height (m)							
Average	0.38	0.39	0.34	0.33	0.33	0.37	0.36
Significant wave height (m)							
Wave energy (J/m^2)	2,023,957.38	1,985,017.55	1,514,603.92	1,412,419.51	1,490,013.79	1,987,140.57	1,735,525.45

Year	2003	2004	Average
Maximum	1.42	1.43	1.43
Significant wave height (m)			
Average	0.33	0.38	0.36
Significant wave height (m)			
Wave energy (J/m^2)	1,376,824.05	1,828,188.83	1,602,506.44

TABLE II
THE EROSION RATE AT BANGKHUNTIEN SHORELINE

Year	Average erosion rate m/yr
1980-1986	1.8
1987-1993	4.75
1994-1996	15.28
1997-2002	10.03