

# A New Cut-Through Mechanism in IEEE 802.16 Mesh Networks

Yi-Ting Mai, Chun-Chuan Yang, and Cheng-Jung Wen

**Abstract**—IEEE 802.16 is a new wireless technology standard, it has some advantages, including wider coverage, higher bandwidth, and QoS support. As the new wireless technology for last mile solution, there are designed two models in IEEE 802.16 standard. One is PMP (point to multipoint) and the other is Mesh. In this paper we only focus on IEEE 802.16 Mesh model. According to the IEEE 802.16 standard description, Mesh model has two scheduling modes, centralized and distributed. Considering the pros and cons of the two scheduling, we present the combined scheduling QoS framework that the BS (Base Station) controls time frame scheduling and selects the shortest path from source to destination directly. On the other hand, we propose the Expedited Queue mechanism to cut down the transmission time. The EQ mechanism can reduce a lot of end-to-end delay in our QoS framework. Simulation study has shown that the average delay is smaller than contrasts. Furthermore, our proposed scheme can also achieve higher performance.

**Keywords**—IEEE 802.16 Mesh, Scheduling, Expedited Queue, QoS.

## I. INTRODUCTION

SINCE 1998, IEEE 802.16 working group has launched a standardization process called *Wireless Metropolitan Area Network (Wireless MAN<sup>TM</sup>)* for BWA. The newly released specification of 802.16 (*IEEE Std 802.16-2004*) [1] focuses on fixed location wireless access and can support up to 134 Mbps bit rate. Moreover, the standardization of a new 802.16 interface, *802.16e* [2], to support wireless access with high mobility has also been completed recently. The *WiMax Forum (Worldwide Interoperability for Microwave Access)* [3], [4], a wireless industry consortium with about 100 members including major vendors such as *AT&T*, *Fujitsu*, *Intel*, and *Siemens Mobile*, is supporting 802.16 technology and promoting its commercial use, which means 802.16 is becoming the most important technology in BWA.

As illustrated in Fig. 1-(a), the basic *PMP (Point to Multipoint)* configuration of 802.16 network consists of a *base station (BS)* and a couple of *subscriber stations (SS)* that connect to the BS via high-speed wireless link. The BS acts as a

gateway to the Internet. Legacy LANs or even more complex subnet systems can connect to the 802.16 network via SS. An 802.16 network (including the Legacy LANs that connect to the SS) can cover a large geographical area since the distance between the BS and the SS can be up to 30 miles (in the case of 802.16-2004). Some articles [5]-[6] was proposed QoS support in IEEE 802.16 PMP network. On the other hand, as an extension of 802.16 PMP configuration, the *802.16 Mesh* mode provides that there is no need to have direct link from subscriber stations to the base station and a node can choose the links and path with best quality to transmit data and avoid the congested area. The 802.16 Mesh configuration is illustrated in Fig. 1-(b).

There are two basic mechanisms to schedule data transmission in the IEEE 802.16 mesh network [1]: *centralized* and *distributed scheduling*. In centralized scheduling, the BS works like the cluster head and determines time slot allocation of each SS. In order to transmit data packets, the SS is required to submit the request packet (Layer 2 frame namely *BW\_REQ*) to the BS via the control channel. The BS grants the access request by sending the slot allocation schedule called *UL\_MAP (uplink map for slot access)* to all SS nodes. Since all the control and data packets need to go through the BS, the scheduling procedure is simple, however a longer path in the mesh network is inevitable. On the other hand, in distributed scheduling, every node competes for channel access using an election algorithm based on the scheduling information of the two-hop neighbors. Distributed scheduling is more flexible in terms of route selection (e.g. shortest path route can be used) at the cost of higher signaling overhead for the exchange of scheduling information. Some research works [7]-[10], there have designed for routing and transmission tree construction in centralized scheduling. [11]-[14] are focused on the performance improvement in distributed scheduling. So those scheduling improvement in the 802.16 mesh network has been proposed in the literatures. In this paper, we focus on the combined scheduling with QoS support and propose a new cut-through mechanism for lower end-to-end delay in the 802.16 mesh network.

The remainder of the paper is organized as follows. First of all, we present the overall architecture as well as the novel features of the proposed QoS framework at the BS and SS in section II. Key mechanisms in the proposed framework for QoS support in IEEE 802.16 Mesh network are presented in section III. Simulation study for performance evaluation and comparisons is presented in section IV. Finally, section V concludes this paper.

Yi-Ting Mai is an Assistant Professor at the Department of Information and Networking Technology, Hsiuping Institute of Technology, Dali, Taiwan, R.O.C. (corresponding author to provide phone: 886-4-24961100; e-mail: wkb@mail.hit.edu.tw).

Chun-Chuan Yang is a Full Professor at the Department of Computer Science and Information Engineering, National Chi-Nan University (NCNU), Puli, Taiwan, R.O.C. (e-mail: ccyang@csie.nnu.edu.tw).

Cheng-Jung Wen is an engineer at ZyXEL communications corporation, Hsinchu, Taiwan, R.O.C. (e-mail: gunfighter@mail2000.com.tw).

## II. QoS FRAMEWORK

There are both pros and cons in the basic centralized and distributed scheduling schemes for the IEEE 802.16 Mesh networks. The centralized scheduling scheme has the advantage of centralized control with better and more effective QoS support but suffers from the longer transmission path. Since there is only one physical wireless link in the Mesh network, a longer transmission path implies that a packet goes through the link many times and results in the increase of the consumption of link capacity. On the other hand, the distributed scheduling scheme has the advantage of using minimal-hop-count route but suffers from the larger signaling cost due to 2-hop neighbors competition for channel access. Therefore, we try to design a QoS framework that makes the best of the advantages of the centralized and distributed scheduling schemes and avoids their disadvantages as much as possible.

Fig. 2 displays the architecture of the proposed QoS framework at the BS and SS nodes. The main idea behind the framework is that we take advantage of the centralized control for scheduling and route selection. However, we avoid the longer transmission path by adopting the flow setup phase and maintaining routing information at each SS for QoS flows (the traffic flow applying for IP QoS service) to provide more efficient route control. Novel features of the QoS framework are listed as follows:

(1) The framework adopts cross-layer integration that incorporates some IP layer functionalities at the BS and SS nodes, such as processing and interpretation of IP header, mapping of L3 service types to 802.16 service types (item ①), admission control and route selection according to current load of the network (item ②), flow table setup for routing in the Mesh network (item ③), etc.

(2) The BS works as the centralized controller of QoS support, maintains topological and current link state information (in the link delay database), and is responsible for admission control, route selection, and scheduling of data transmission (item ②).

(3) After the BS determines the routing path for an accepted flow, the routing path is established before data transmission via setting up the flow table (item ③) at each SS along the path. A routing tag denoted by  $R_{tag}$  is assigned and added in the flow table for fast routing the traffic of the flow (item ④).

(4) Subscriber stations access the data channel in the allocated time slots according to the instruction (UL-MAP) from the BS, and transmit data packets to the next hop according to the value of  $R_{tag}$  added in the header of the data frame and the flow table (item ⑤). Note that using  $R_{tag}$  in the header of 802.16 data frame for fast packet routing is similar to the idea of *Multi-Protocol Label Switching (MPLS)* [15]. Moreover, each SS estimates its current link delay (the system time of each QoS queue in the SS) and reports its link state to the BS for updating the link delay database on a regular basis.

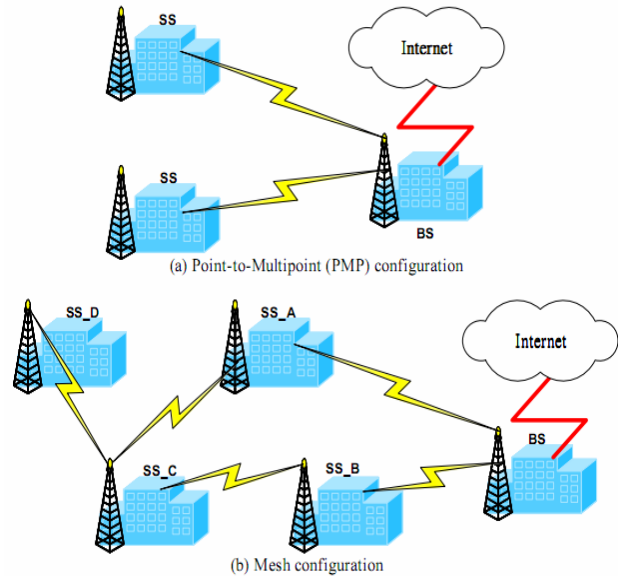

Fig. 1 Two configurations in IEEE 802.16

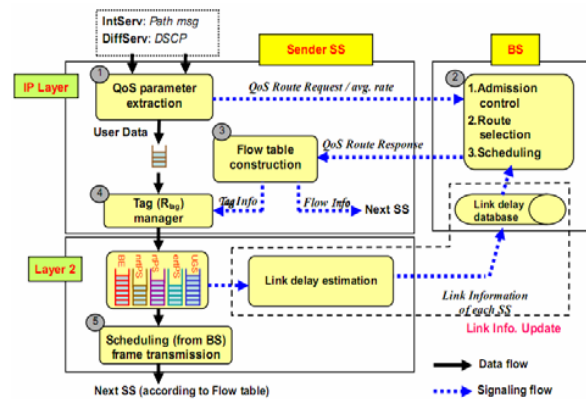

Fig. 2 QoS framework

## III. QoS SCHEDULING

The IEEE 802.16 provides the QoS to achieve the multimedia service in BWA. There are five service types in the 802.16, *Unsolicited Grant Service (UGS)*, *extend real-time Polling Service (ertPS)*, *real-time Polling Service (rtPS)*, *non-real-time Polling Service (nrtPS)*, and *Best Effort (BE)*. Since real time multimedia traffic needs sufficient bandwidth and low delay, the UGS service type designed to support the appropriate service.

A specific scheduling algorithm is not described for PMP or for mesh modes in the IEEE 802.16 standard [1]-[2], because it is not included among the mandatory modules required for the standardized operation of system. On the other hand, the operation of the scheduler is important for the performance of the whole system, and this is why it has attracted growing attention over the last couple of years. In the literature so far, a limited number of papers can be found proposing scheduling

algorithms for 802.16. Those proposals are based mostly on extensions and combinations of ideas already applied in systems prior to IEEE 802.16, such as the IEEE 802.11 wireless local-area network, and they focus mainly on the PMP mode.

To achieve the requirement for each service type, we focus on two parts, designing the special bandwidth request for highest priority of UGS, adding the weight of delay for different SSs with the same service type and using appropriate scheme of slot allocation. The detail is showed as follows.

#### A. Expedited Queue

In the PMP (Point to Multipoint) mode, the BS and a couple of SSs that connect to the BS via high-speed wireless link, and the BS according to the initiation UGS request to allocate the fixed bandwidth for the CBR traffic session. However, the ertPS, rtPS and nrtPS are Polling Service, these types should dynamic request to BS in each frame. Therefore, those service types are designed for VBR-rt traffic or lower priority non-real time traffic. On the other hand, the other mode of 802.16 Mesh has different situation, the traffic flow transmission might be divided into multi-hop according to the flow path, so the traditional bandwidth requests (BW\_REQ) is sending by each intermediate SS. The QoS service types only apply different priorities like Polling Service. Since the UGS flow is the highest priority and fixed bandwidth requirement, it is unnecessary to be allocated per time frame, so the UGS traffic can be granted in initiation request with one time request like PMP mode. To support UGS traffic with initiation bandwidth request (BW\_REQ), we should adopt idea of cut-through in ATM network. In our proposed *Expedited Queue (EQ)* scheduling scheme, when the traffic flow passed the admission control policy and belonged to UGS service, the resource allocation function should consider both per hop BW\_REQ and end-to-end route path. Our *EQ* scheme provides absolute QoS guarantee for UGS service type with highest priority. We add a special queue in each SS for supporting UGS flow, and it is no need to be scheduled. When sender SS of UGS flow requests BW\_REQ, the BS allocated the slots based on its request slots and number hop of route path (*request slots \* hop count*). The *EQ* scheme can reduce a fewer signal overheads and apply lower end-to-end delay.

#### B. Delay-based Weight Design

The scheduling algorithm in the framework is similar to the centralized scheduling controlled by the BS but with delay considerations. Rules in the proposed scheduling algorithm include: (1) UGS (Unsolicited Grant Service) flows have higher priorities than ertPS (Extend real-time Polling Service) flows, ertPS flows are also higher than rtPS (Real-time Polling Service), etc. (2) Within the same service type, the SS with higher load has a higher priority. (3) Moreover, an additional mechanism is adopted for real-time flows such as UGS, ertPS and rtPS to reduce the access delay by giving higher priority to those data frames that have been waiting a longer time in the queue. More specifically, the data frames with the waiting time exceeding the delay bound specified in the flow setup phase

have higher priorities than those frames with smaller waiting times. An elaborate weighting function integrating the above rules is designed for determining the access sequence that tries to minimize the access delay of real-time data packets as explained in the following.

The weighting function is used by the BS to determine the transmission priority (denoted by *XMT*) of each queue at each SS. The BS collects the queue length (in the number of data frames) of each service type at  $SS_i$ , i.e.  $D_{UGS,i}$ ,  $D_{ertPS,i}$ ,  $D_{rtPS,i}$ ,  $D_{nrtPS,i}$  and  $D_{BE,i}$ . For delay-constrained service types such as UGS, ertPS and rtPS, one more parameter (denoted by  $W_{UGS,i}$ ,  $W_{ertPS,i}$  and  $W_{rtPS,i}$ ) of the number of data frames in the queue of which their queuing time exceeding their delay bound is also collected. In order to give delayed UGS, ertPS and rtPS data frames higher priorities in scheduling, we define a delay compensation factor (denoted by *DC* and  $DC=5$  is used in our simulation) for  $W_{UGS,i}$ ,  $W_{ertPS,i}$  and  $W_{rtPS,i}$ . The weighting functions for UGS, ertPS and rtPS queues are therefore defined respectively as follows:

$$XMT_{UGS,i} = W_{UGS,i} \times DC + (D_{UGS,i} - W_{UGS,i})$$

$$XMT_{ertPS,i} = W_{ertPS,i} \times DC + (D_{ertPS,i} - W_{ertPS,i})$$

$$XMT_{rtPS,i} = W_{rtPS,i} \times DC + (D_{rtPS,i} - W_{rtPS,i})$$

Note that the values of *XMT* for nrtPS and BS queues are simply  $D_{nrtPS,i}$  and  $D_{BE,i}$ .

## IV. PERFORMANCE EVALUATION

### A. Simulation Environment and Parameter

Simulation study has been conducted to evaluate the proposed scheduling (with and w/o EQ scheme). Two major contrasts are compared with our proposed schemes: centralized scheduling with routing via BS and distributed scheduling with minimal-hop-count routing. The Mesh network in the simulation is a 5x5 mesh and the BS is located at the center as Fig. 3. Link capacity of the network is 20 Mbps. A time frame structure with size 10ms is defined for slot allocation. Other parameters used in the simulation are displayed in Table I.

There are in total 25 flows (5 flows for each of the five service types) in each round of the simulation. Flows with ID 1~5 are UGS flows, ID 6~10 ertPS flows, etc., and a larger flow ID in each service type is assigned to the flow with a longer Euclidean distance between the source SS and the destination SS. The source SS and destination SS of each flow are randomly selected from the Mesh network. Three performance criteria are defined for comparison: (1) Average delay (ms) of data frames per hop (SS), (2) Average throughput (Mbps), and (3) Average signaling cost (average number of signaling packets per time frame).

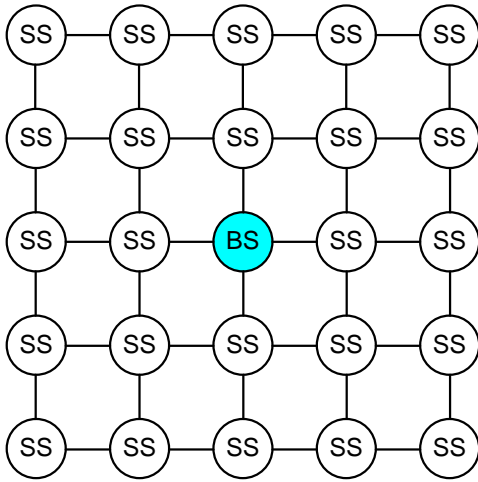

Fig. 3 Simulation topology

TABLE I  
SIMULATIONS PARAMETERS

Description	Value
Network size	5×5 mesh
Link capacity	20 Mbps
Time frame duration	10 ms
# of slots per time frame	200
# of flows per service type	5
Average data rate of per service type flows	0.1~1 Mbps
Std. variation of data rate per non-UGS flow	±25%
Status report interval	100ms

### B. Performance Comparison

As shown in Fig. 4, Fig. 5 and Fig. 6, the *average delay* and *delay variation* per hop for different service types under total flow data rate 0.5, 2.5, and 5Mbps in the proposed schemes are smaller than those of the centralized schemes and much smaller than those of the distributed scheme. For lower priority nrtPS and BE, centralized schemes have increased exponentially when load is growing. Furthermore, our proposed and centralized scheduling with EQ have lower *average delay* in UGS flow. It is the result of the UGS flow allocated whole path slots in source SS request, so the end-to-end delay can be smaller than a time frame duration (7.4ms in our simulation). For more investigation of delay behavior, Fig. 7-Fig. 11 display the results of the end-to-end *average delay* for different service type of flows under each service type flow data rate ranging from total input traffic 0.5Mbps to 5Mbps. Some observations and interpretations can be made from the figures as follows:

(1) Delay performance of the proposed schemes is better than that of the centralized schemes and much better than that of the distributed scheme. The reason behind the bad delay performance of the centralized schemes is twofold: Firstly, the longer path increases the consumption of the link capacity that is similar to the effect of input load increase. Secondly, no spatial reuse in the standard centralized scheduling makes the

effective capacity in the network smaller than that of our proposed scheme. The factor of longer path makes the bad delay performance in standard centralized schemes. On the other hand, the proposed schemes have beaten the distributed scheme very much even the minimal-hop-count route is used in the distributed scheme. The major reason is based on data sub-frame allocation after the three-way handshaking procedure and only one SS can win by contention scheme in two-hop neighbors with pseudo-random election algorithm. This procedure needs longer period to allocate data slot for winner SS and causes a higher system delay due to a large loser SSs with data on queue.

The *average delay* for all the five schemes goes up while the flow data rate increases with rtPS, nrtPS and BE, because the higher priority of UGS and ertPS are not saturated. However, the significant increase in delay of the centralized schemes reflect the schemes reaching the saturation point of the queuing system at the SS much earlier than the other three schemes. The major reason is again due to the routing mechanism used in the centralized schemes. Our proposed schemes and the distributed scheme are applied higher capacity based on spatial reuse with higher concurrent transmission SSs. Moreover, our proposed schemes present more effect of load distribution when the flow data rate increases. Therefore, the gain of delay performance in the proposed schemes over the other schemes is getting larger under heavy loads.

Since the scheduling algorithms of our proposed schemes and centralized schemes adopt priorities for different service types, the *average delay* of UGS flows is always smaller than that of ertPS flows, and ertPS delay is smaller than rtPS delay, and so on. However, we observe a different characteristic in the distributed scheme that the *average delay* is almost similar in each service type in the distributed scheduling. The specific is due to the contention algorithm and it applies only on each SS without considering QoS flows in the mesh network. Considering the effect of the EQ scheme, in Fig. 7-Fig. 11, only UGS flows have lower delay performance in the two schemes which apply EQ, the other results are almost overlapping because the other service types do not apply the EQ scheme. However, we can see a little difference in nrtPS and BE, because of the UGS flow allocation, and therefore the lower priority queue might be pushed to next time frame.

(2) Fig. 12 shows the *average throughput* of the schemes. As expected, the *average throughput* arises based on data rate increasing. The centralized schemes have higher system utilization than distributed schemes in light load, but these have lower system utilization than distributed scheme in heavy load. It is due to the longer path in centralized schemes. However, the centralized schemes suffer from lower throughput performance than the performance of our proposed schemes due to the same reasons of bad delay performance with longer path. When data rate is increasing, the centralized schemes are easier to reach saturated point than the other schemes because the specific of spatial reuse can enhance link capacity and slow down the scheme reaching the saturated situation. For EQ scheme, the total throughput in Fig. 12, it is almost the same in those two

schemes. It only affects the delay performance in the mesh network in the EQ scheme.

(3) The *average signaling cost* of the schemes is shown in Fig. 13, in which the distributed scheme presents the most signaling cost due to 2-hop information exchange in competition of channel access. The proposed schemes have slightly higher than the centralized schemes in terms of the signaling cost because the periodically reporting is adopted in our proposed scheme. However, the signaling cost does not increase with load growing up because the all mesh SSs are almost requesting per time frame when total data rate is 2.5 Mbps. Furthermore, the EQ scheme only needs to send an UGS request in source SS, so the EQ scheme has decreased the total signal about 5% in proposed and centralized schemes.

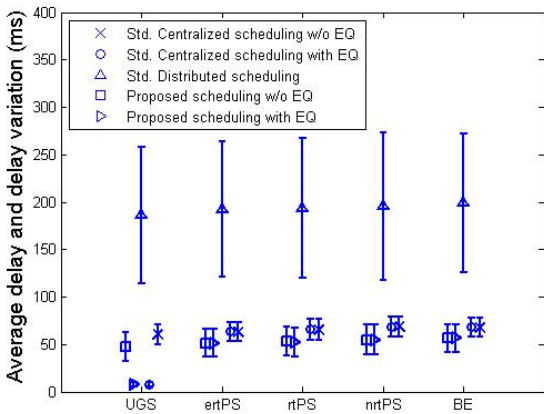

Fig. 4 Delay and delay variation with total flow data rate 0.5 Mbps

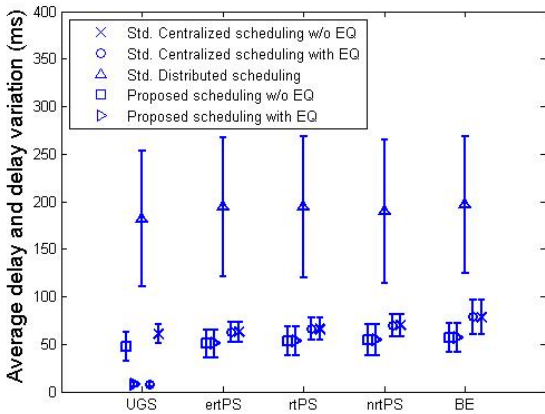

Fig. 5 Delay and delay variation with total flow data rate 2.5 Mbps

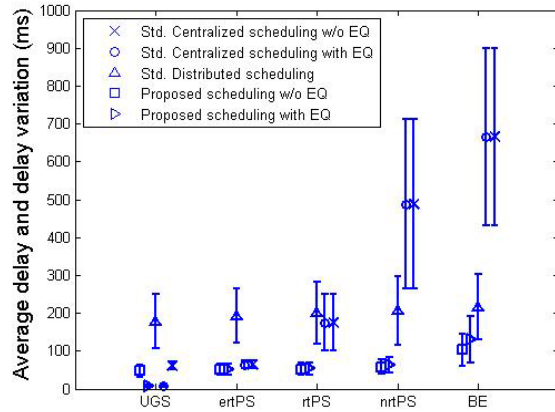

Fig. 6 Delay and delay variation with total flow data rate 5 Mbps

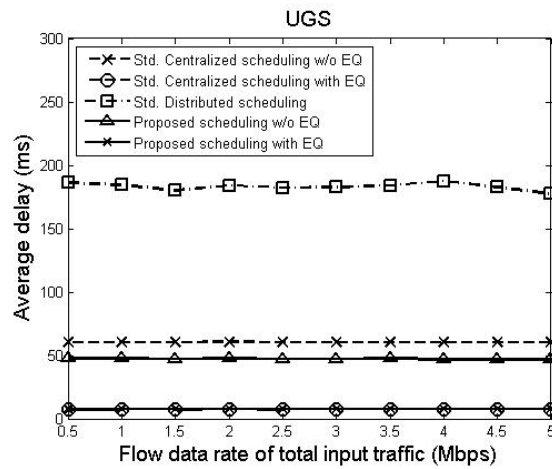

Fig. 7 Average delay of UGS flows

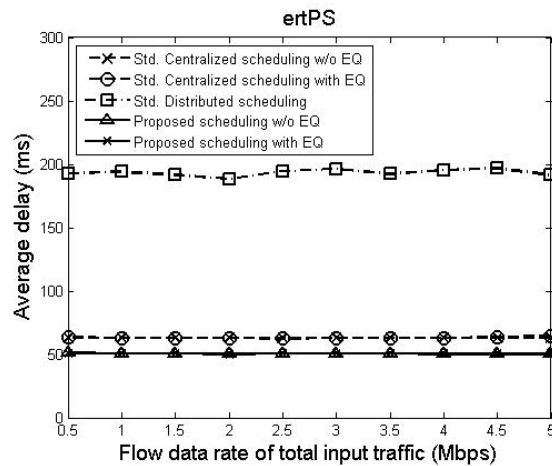

Fig. 8 Average delay of ertPS flows

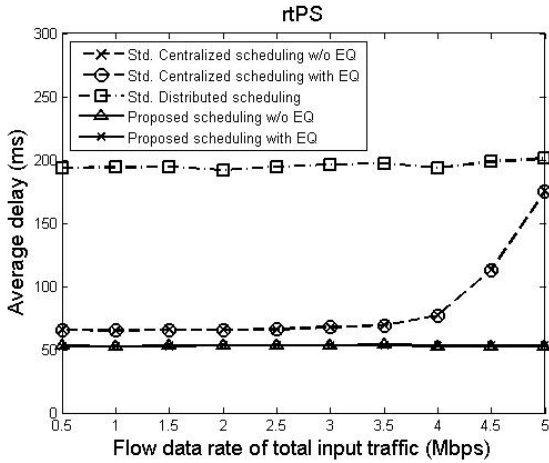

Fig. 9 Average delay of rtPS flows

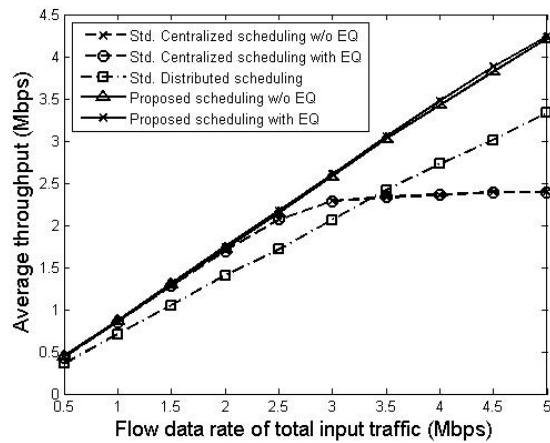

Fig. 12 Average throughput of all flows

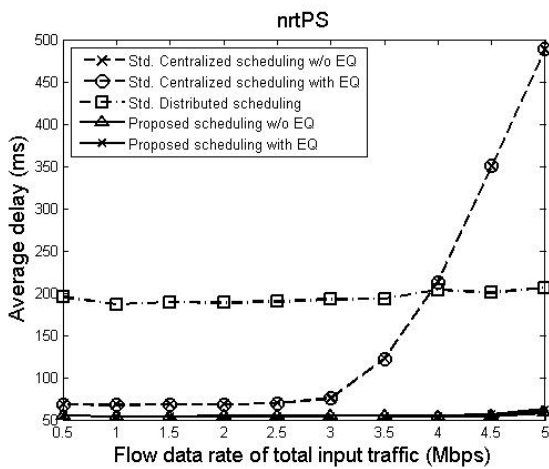

Fig. 10 Average delay of nrtPS flows

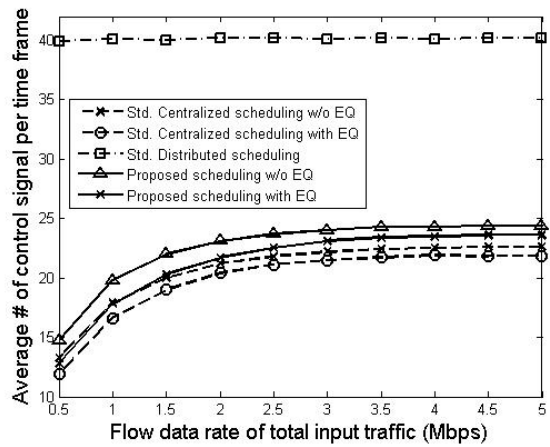

Fig. 13 Average signaling cost

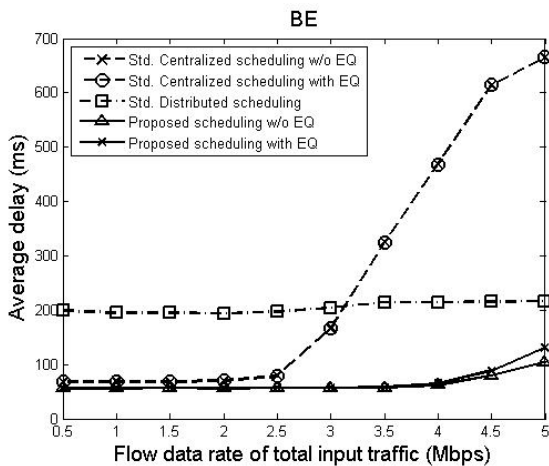

Fig. 11 Average delay of BE flows

## V. CONCLUSION

In the Mesh mode, there is no need to have direct link from SSS to the BS, which provides a more flexible approach for network deployment. Data frames in the 802.16 Mesh mode can be transmitted directly between two neighboring SS nodes and sent to the destination node in the hop-by-hop manner. Therefore, routing and scheduling with QoS support are important issues in the IEEE 802.16 Mesh network. Two basic scheduling schemes, the centralized scheme and the distributed scheme, associated with their corresponding routing mechanisms were defined in the 802.16 standard. In this paper, we have investigated the performance problems in each of the basic schemes and proposed more efficient scheduling mechanisms.

Moreover, a QoS framework incorporating the proposed routing and scheduling mechanisms were also presented in this paper. Core mechanisms in the framework include: mapping of IP QoS classes to 802.16 service types, admission control for QoS flows, minimal-hop-count route selection, tag-based fast routing, expedited queue, and delay-based scheduling. Simulation results have demonstrated that the proposed framework and the associated mechanisms can achieve a better

performance in terms of delay, throughput, and signaling cost over the basic centralized and distributed scheduling schemes. On the other hand, our proposed EQ mechanism can reduce larger transmission time than traditional mechanism.

#### ACKNOWLEDGMENT

This work was supported in part by the National Science Council, Taiwan, R.O.C., under grant NSC97-2218-E-164-002.

#### REFERENCES

- [1] IEEE Std 802.16-2004, "IEEE Standard for Local and Metropolitan Area Networks--Part 16: Air Interface for Fixed Broadband Wireless Access Systems," Oct. 2004.
- [2] IEEE Std 802.16e-2005, "IEEE Standard for Local and Metropolitan Area Networks--Part 16: Air Interface for Fixed Broadband Wireless Access Systems—Amendment 2: Physical and Medium Access Control Layers for Combined Fixed and Mobile Operation in Licensed Bands," Feb. 2006.
- [3] "Business Case Models for Fixed Broadband Wireless Access Based on WiMAX Technology and the 802.16 Standard," WiMax Forum, 10 Oct. 2004.
- [4] S. J. Vaughan-Nichols, "Achieving Wireless BroadBand with WiMax," IEEE Computer, pp.10-13, Jun. 2004.
- [5] D. Niyato, and E. Hossain, "Queue-aware Uplink Bandwidth Allocation and Rate Control for Polling Service in IEEE 802.16 Broadband Wireless Networks," IEEE Transactions on Mobile Computing, vol. 5, no. 6, pp. 668-679 Jun. 2006.
- [6] Y. T. Mai, C. C. Yang, and Y. H. Lin, "Design of the Cross-Layer QoS Framework for the IEEE 802.16 PMP Networks," IEICE Transactions on Communications, vol. E91-B, no. 5, pp. 1360-1369, May 2008.
- [7] R. Hincapie, J. Sierra, and R. Bustamante, "Remote Locations Coverage Analysis with Wireless Mesh Networks Based on IEEE 802.16 Standard," IEEE Communications Magazine, vol. 45, no. 1, pp. 120-127, Jan. 2007.
- [8] B. Han, W. Jia, and L. Lin "Performance Evaluation of Scheduling in IEEE 802.16 Based Wireless Mesh Networks," Journal of Computer communications, vol. 30, no. 4, pp. 782-792, Feb. 2007.
- [9] S. Nahle, L. Iannone, B. Donnet, and N. Malouch, "On the Construction of WiMax Mesh Tree," IEEE Communications Letters, vol. 11, no. 12, pp. 967-969, Dec. 2007.
- [10] M. S. Kuran, G. Gur, T. Tuğcu, and F. Alagöz, "Cross-Layer Routing-Scheduling in IEEE 802.16 Mesh Networks," in Proceedings of the 1<sup>st</sup> International Conference on MOBILE Wireless MiddleWARE, Operating Systems, and Applications, 2008 (MOBILWARE'08), Feb. 2008.
- [11] M. Cao, W. Ma, Q. Zhang, and X. Wang, "Analysis of IEEE 802.16 Mesh Mode Scheduler Performance," IEEE Transaction on Wireless Communications, vol. 6, no. 4, pp. 1455-1464, Apr. 2007.
- [12] Y. Zhang, J. Zheng, and W. Li, "A Simple and Effective QoS Differentiation Scheme in IEEE 802.16 WiMax Mesh Networking," in Proceedings of IEEE Wireless Communications and Networking Conference (WCNC 2007), pp. 3218-3222, Mar. 2007.
- [13] C. Cicconetti, A. Erta, L. Lenzi, and E. Mingozzi, "Performance Evaluation of the Mesh Election Procedure of IEEE 802.16/Wimax," in Proceedings of the 10<sup>th</sup> ACM Symposium on Modeling, analysis, and simulation of wireless and mobile systems (MSWiM'07), pp. 323-327, Oct. 2007.
- [14] H. Hu, Y. Zhang, and H. H. Chen, "An Effective QoS Differentiation Scheme for Wireless Mesh Networks," IEEE Network, vol. 22, no. 1, pp. 66-73, Jan.-Feb. 2008.
- [15] E. Rosen, A. Viswanathan, and R. Callon, "Multiprotocol Label Switching Architecture," IETF RFC3031, Jan. 2001.