

A Model for Analyzing the Startup Dynamics of a Belt Transmission Driven by a DC Motor

Giovanni Incerti

Abstract—In this paper the vibration of a synchronous belt drive during start-up is analyzed and discussed. Besides considering the belt elasticity, the model here proposed also takes into consideration the electromagnetic response of the DC motor. The solution of the motion equations is obtained by means of the modal analysis in state space, which allows to obtain the decoupling of all equations, without introducing the hypothesis of proportional damping. The mathematical model of the transmission and the solution algorithms have been implemented within a computing software that allows the user to simulate the dynamics of the system and to evaluate the effects due to the elasticity of the belt branches and to the electromagnetic behavior of the DC motor. In order to show the details of the calculation procedure, the paper presents a case study developed with the aid of the above-mentioned software.

Keywords—Belt drive, Vibrations, Startup, DC motor.

I. INTRODUCTION

IN many industrial devices the motion transmission between parallel axes is obtained by means of belt drive systems, which allow to obtain low noise operation, good mechanical efficiency and low cost design solutions.

However, for high dynamic loads, a belt transmission can introduce unwanted vibrations on the devices to be operated; as is well known, these phenomena largely depend on the elasticity of the branches of the belt and occur especially for multi-stage configurations arranged in series.

Based on these considerations, it is important to verify, already at the design stage, the vibration of the transmission in its real operating conditions. Furthermore, the study is more accurate if the mathematical model of the system takes into account, at the same time, the deformation of the belt and the electromagnetic behavior of the motor. In this context, the paper aims to provide a contribution on the subject, presenting a model of the complete electromechanical system, in which the motion equations related to the mechanical components (belt drive and pulleys) are solved together with the equation that describes the electrical response of the motor.

In order to clarify the proposed approach we will analyze a typical configuration, which consists of a DC motor, a belt drive and a resistive load, paying particular attention to the possibility of analytically solve the differential equations of motion, without using a numerical integration method.

II. MATHEMATICAL MODELING OF THE SYSTEM

To evaluate the dynamics of belt transmissions, taking into account the axial deformability of the branches, lumped parameter models are usually adopted; using this approach a system of ordinary differential equations is written and solved.

G. Incerti is with the Department of Mechanical and Industrial Engineering, University of Brescia, 25123 Brescia, Italy, (e-mail: giovanni.incerti@unibs.it).

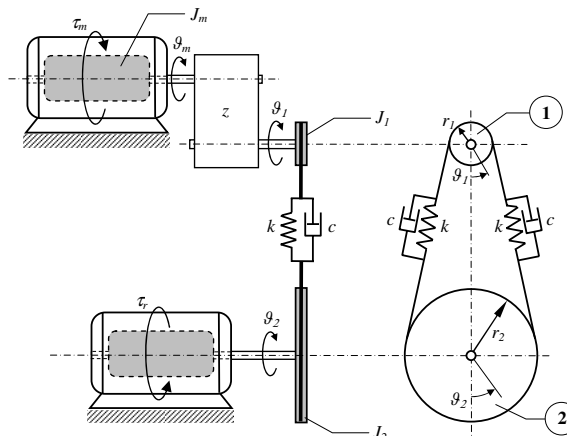

Fig. 1. Schematic representation of the electromechanical system analyzed in the paper. Each branch of the belt is modeled using a viscoelastic model (spring and damper in parallel).

This approach, which allows to limit the complexity of the mathematical model, has been used in several works found in the technical literature: for example, in [1] the authors analyze belt transmissions with complex geometries and propose an algorithm for the automatic deduction of the motion equations of a system having an arbitrary number of belts and pulleys.

In [2] a lumped parameter model has been developed for a belt-driven robot, in order to study some dynamic effects and to optimize the control strategy of the machine.

A study of dynamic characteristics of a differential, planetary, path-generating mechanism with a synchronous belt is presented in [3]; by accounting for the belt elasticity and employing a Lagrangian approach, a dynamic model of the mechanism is obtained; the effects of belt drive speed ratio, belt material damping and planet link balancing on the mechanism behavior are investigated by the authors.

In general the motion equations for a mechanical system can be derived by imposing conditions of dynamic equilibrium or by using the Lagrange equations: usually the following assumptions are considered:

- the belt branches are modeled by linear springs in parallel with viscous dampers;
- the belt mass is negligible compared to the pulleys mass;
- the motion transmission takes place in ideal kinematic conditions (absence of slippage, due to the use of a synchronous belt);
- the belt has no flexural stiffness.

The stiffness k of the belt branches can be determined by the well-known relationship $k = EA/l$, where E is the Young's

modulus of the belt material, A is the cross sectional area of the branch and l its length; the damping coefficient c can be experimentally determined through free vibration tests (for example using the logarithmic decrement method [4]).

As a case study, we consider the system shown in Fig. 1, consisting of a DC motor, a gear speed reducer, a synchronous belt drive and a resistant load, which provides a torque linearly variable as a function of speed.

As regards the mechanical part, we observe that the system has two degrees of freedom (DOF), represented by the angular coordinates ϑ_1 e ϑ_2 ; the rotation ϑ_m of the motor is proportional to the rotation ϑ_1 according to the assigned transmission ratio assigned z ($\vartheta_m = z\vartheta_1$) and therefore it does not represent an additional degree of freedom.

To analyze the dynamics of the system we use the Lagrange equations, which, for the case under consideration, assume the following form:

$$\frac{d}{dt} \left(\frac{\partial T}{\partial \dot{\vartheta}_i} \right) - \frac{\partial T}{\partial \vartheta_i} + \frac{\partial D}{\partial \dot{\vartheta}_i} + \frac{\partial U}{\partial \vartheta_i} = \frac{\delta W}{\delta \vartheta_i} \quad i = 1, 2 \quad (1)$$

where the symbols T , D , U and W respectively indicate the kinetic energy of the system, the Rayleigh dissipation function, the potential energy due to the elastic deformation of the belt branches and the work done by the external actions (motor torque and the load torque) acting on the system. The complete list of the symbols used in the equations is given in Appendix C.

For a permanent magnet DC motor the torque τ_m is proportional to the current I that flows in the armature circuit; the load torque τ_r acting on the system can be considered as the sum of a constant term τ_{r0} and linearly variable term with the angular speed $\dot{\vartheta}_2$. Therefore will be valid the following relationships:

$$\tau_m = k_m I \quad \tau_r = \tau_{r0} + \mu \dot{\vartheta}_2 \quad (2)$$

The virtual work done by the motor and the load torque is:

$$\delta W = z\tau_m \delta \vartheta_1 - \tau_r \delta \vartheta_2 \quad (3)$$

Using the sign conventions shown in Fig. 1 the kinetic energy can be written as:

$$T = \frac{1}{2} (J_1^* \dot{\vartheta}_1^2 + J_2 \dot{\vartheta}_2^2) \quad (4)$$

where $J_1^* = J_1 + z^2 J_m$. The potential energy and the Rayleigh dissipation function assume the following expressions:

$$U = k(r_1 \vartheta_1 - r_2 \vartheta_2)^2 \quad D = c(r_1 \dot{\vartheta}_1 - r_2 \dot{\vartheta}_2)^2 \quad (5)$$

Substituting the above expressions into (1) and calculating the required derivatives we obtain the motion equations of the device shown in Fig. 1:

$$\begin{cases} J_1^* \ddot{\vartheta}_1 + 2cr_1^2 \dot{\vartheta}_1 - 2cr_1 r_2 \dot{\vartheta}_2 + \\ \quad + 2kr_1^2 \vartheta_1 - 2kr_1 r_2 \vartheta_2 = zk_m I \\ J_2 \ddot{\vartheta}_2 - 2cr_1 r_2 \dot{\vartheta}_1 + 2cr_2^2 \dot{\vartheta}_2 - 2kr_1 r_2 \vartheta_1 + \\ \quad + 2kr_2^2 \vartheta_2 = -(\tau_{r0} + \mu \dot{\vartheta}_2) \end{cases} \quad (6)$$

As regards the electric behavior of the motor, the application of the Kirchhoff's voltage law to the armature circuit of the motor gives (see Fig. 2):

$$V(t) = RI + L\dot{I} + zk_m \dot{\vartheta}_1 \quad (7)$$

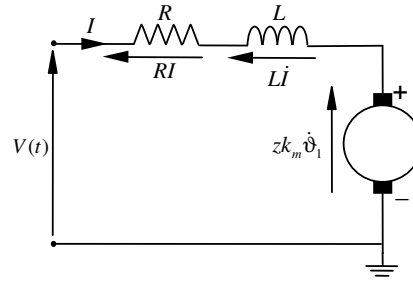

Fig. 2. Armature circuit of the DC motor.

At this point we made explicit (6) with respect to the angular accelerations $\ddot{\vartheta}_1$ e $\ddot{\vartheta}_2$ and (7) with respect to the time derivative of the armature current; finally we introduce the two identities $\dot{\vartheta}_1 = \dot{\vartheta}_1$ e $\dot{\vartheta}_2 = \dot{\vartheta}_2$, obtaining in this way the following system of differential equations:

$$\begin{cases} \dot{\vartheta}_1 = \dot{\vartheta}_1 \\ \dot{\vartheta}_2 = \dot{\vartheta}_2 \\ \ddot{\vartheta}_1 = \frac{1}{J_1^*} (-2kr_1^2 \vartheta_1 + 2kr_1 r_2 \vartheta_2 - 2cr_1^2 \dot{\vartheta}_1 + \\ \quad + 2cr_1 r_2 \dot{\vartheta}_2 + zk_m I) \\ \ddot{\vartheta}_2 = \frac{1}{J_2} [2kr_1 r_2 \vartheta_1 - 2kr_2^2 \vartheta_2 + \\ \quad + 2cr_1 r_2 \dot{\vartheta}_1 - (2cr_2^2 + \mu) \dot{\vartheta}_2 - \tau_{r0}] \\ \dot{I} = \frac{1}{L} [-zk_m \dot{\vartheta}_1 - RI + V(t)] \end{cases} \quad (8)$$

Using matrix notation, (8) can be rewritten in the form:

$$\dot{\mathbf{x}}(t) = \mathbf{A}\mathbf{x}(t) + \mathbf{B}\mathbf{u}(t) \quad (9)$$

where:

$$\mathbf{A} = \begin{bmatrix} 0 & 0 & 1 & 0 & 0 \\ 0 & 0 & 0 & 1 & 0 \\ -\frac{2kr_1^2}{J_1^*} & \frac{2kr_1 r_2}{J_1^*} & -\frac{2cr_1^2}{J_1^*} & \frac{2cr_1 r_2}{J_1^*} & \frac{zk_m}{J_1^*} \\ \frac{2kr_1 r_2}{J_2} & -\frac{2kr_2^2}{J_2} & \frac{2cr_1 r_2}{J_2} & -\frac{2cr_2^2 + \mu}{J_2} & 0 \\ 0 & 0 & -\frac{zk_m}{L} & 0 & -\frac{R}{L} \end{bmatrix} \quad (10)$$

$$\mathbf{B} = \begin{bmatrix} 0 & 0 \\ 0 & 0 \\ 0 & 0 \\ -\frac{1}{J_2} & 0 \\ 0 & \frac{1}{L} \end{bmatrix} \quad (11)$$

$$\mathbf{x}(t) = \{ \vartheta_1(t) \quad \vartheta_2(t) \quad \dot{\vartheta}_1(t) \quad \dot{\vartheta}_2(t) \quad I(t) \}^T \quad (12)$$

$$\mathbf{u}(t) = \{ \tau_{r0} \quad V(t) \}^T \quad (13)$$

As is known, \mathbf{A} and \mathbf{x} are respectively the *state matrix* and the *state vector* of the system, \mathbf{u} is the *input vector* and \mathbf{B} the *input matrix*. The differential equations here obtained are linear and for their solution the analytical method described in the next section can be used.

III. ANALYTICAL SOLUTION IN STATE SPACE

An analytical solution for the system of equations (9) can be found using the *modal analysis in state space*; this procedure requires the calculation of two different types of eigenvectors [5] [6]. We proceed by considering first the problem of free vibrations (or homogeneous problem), obtained by imposing $\mathbf{u}(t) = \mathbf{0}$; from (9) we get:

$$\dot{\mathbf{x}}(t) = \mathbf{A}\mathbf{x}(t) \quad (14)$$

Equation (14) represents in matrix form a system of five first-order ordinary differential equations with constant coefficients, whose solution is:

$$\mathbf{x}(t) = \mathbf{x}e^{\lambda t} \quad (15)$$

where \mathbf{x} is a constant vector and λ a constant scalar. By substituting (15) into (14) and simplifying the exponential term on both sides, we obtain:

$$\mathbf{A}\mathbf{x} = \lambda\mathbf{x} \quad (16)$$

Equation (16) represents the eigenvalue problem with a nonsymmetric real matrix \mathbf{A} . The solution of (16) gives the eigenvalues λ_i and the corresponding eigenvectors \mathbf{x}_i , ($i = 1, \dots, 5$). These eigenvalues can be real or complex. Since \mathbf{A} is a real matrix, if λ_i is a complex eigenvalue, its complex conjugate $\bar{\lambda}_i$ will also be an eigenvalue of \mathbf{A} ; moreover the eigenvectors \mathbf{x}_i and $\bar{\mathbf{x}}_i$, corresponding to λ_i and $\bar{\lambda}_i$, will also be complex conjugates to one another.

Now let us consider the eigenvalues-eigenvectors problem for the transposed matrix \mathbf{A}^T :

$$\mathbf{A}^T\mathbf{y} = \lambda\mathbf{y} \quad (17)$$

Since the determinants of \mathbf{A} and \mathbf{A}^T are equal, (16) and (17) generates the same characteristic equation, i.e.:

$$|\mathbf{A} - \lambda\mathbf{I}| \equiv |\mathbf{A}^T - \lambda\mathbf{I}| = 0 \quad (18)$$

where \mathbf{I} is the 5×5 identity matrix. Consequently the eigenvalues of \mathbf{A} and \mathbf{A}^T are identical; on the contrary the eigenvectors of these matrices will be different.

The eigenvectors \mathbf{x}_i , $i = 1, \dots, 5$ of \mathbf{A} are called *right eigenvectors*, whereas the eigenvectors \mathbf{y}_j , $j = 1, \dots, 5$ of \mathbf{A}^T are called *left eigenvectors*; more details about these denominations are given in Appendix A.

The right eigenvalues \mathbf{x}_i and the left eigenvalues \mathbf{y}_i are the columns of the matrices \mathbf{X} and \mathbf{Y} , which are defined by the following relationships:

$$\mathbf{X} = [\mathbf{x}_1 \ \mathbf{x}_2 \ \mathbf{x}_3 \ \mathbf{x}_4 \ \mathbf{x}_5] \quad \mathbf{Y} = [\mathbf{y}_1 \ \mathbf{y}_2 \ \mathbf{y}_3 \ \mathbf{y}_4 \ \mathbf{y}_5] \quad (19)$$

If the eigenvectors \mathbf{X} and \mathbf{Y} are properly normalized, the following equations are valid (see Appendix B for details):

$$\mathbf{Y}^T\mathbf{X} = \mathbf{I} \quad \mathbf{Y}^T\mathbf{A}\mathbf{X} = \mathbf{\Lambda} \quad (20)$$

where $\mathbf{\Lambda}$ is the 5×5 diagonal matrix of eigenvalues, i.e.:

$$\mathbf{\Lambda} = \begin{bmatrix} \lambda_1 & 0 & 0 & 0 & 0 \\ 0 & \lambda_2 & 0 & 0 & 0 \\ 0 & 0 & \lambda_3 & 0 & 0 \\ 0 & 0 & 0 & \lambda_4 & 0 \\ 0 & 0 & 0 & 0 & \lambda_5 \end{bmatrix} \quad (21)$$

Now we introduce the linear transformation:

$$\mathbf{x}(t) = \mathbf{X}\boldsymbol{\eta}(t) \quad (22)$$

where $\boldsymbol{\eta} = [\eta_1 \ \eta_2 \ \eta_3 \ \eta_4 \ \eta_5]^T$ is the vector containing the modal coordinates $\eta_i(t)$. Substituting (22) into (9) and premultiplying by \mathbf{Y}^T both sides of the equation, we obtain:

$$\mathbf{Y}^T\mathbf{X}\dot{\boldsymbol{\eta}}(t) = \mathbf{Y}^T\mathbf{A}\mathbf{X}\boldsymbol{\eta}(t) + \mathbf{Y}^T\mathbf{B}\mathbf{u}(t) \quad (23)$$

Considering (20), we can rewrite the above equation in the form:

$$\dot{\boldsymbol{\eta}}(t) = \mathbf{\Lambda}\boldsymbol{\eta}(t) + \mathbf{q}(t) \quad (24)$$

where:

$$\mathbf{q}(t) = \mathbf{Y}^T\mathbf{B}\mathbf{u}(t) \quad (25)$$

In this way we have obtained the complete decoupling of the differential equations that describe the system dynamics, since the matrix equation (24) contains five independent equations, which can be separately solved. Each of them is a first order nonhomogeneous linear differential equation, that can be written as:

$$\dot{\eta}_i(t) = \lambda_i\eta_i(t) + q_i(t) \quad i = 1, \dots, 5 \quad (26)$$

The solution of (26) can be expressed in the general form:

$$\eta_i(t) = \eta_i(0)e^{\lambda_i t} + \int_0^t q_i(\tau)e^{\lambda_i(t-\tau)}d\tau \quad i = 1, \dots, 5 \quad (27)$$

For calculating the initial conditions $\eta_i(0)$ in terms of modal coordinates, it is sufficient to invert (22) and to set $t = 0$:

$$\boldsymbol{\eta}(0) = \mathbf{X}^{-1}\mathbf{x}(0) \quad (28)$$

From the first of (20) we have $\mathbf{X}^{-1} = \mathbf{Y}^T$ and therefore the calculation of the inverse of matrix \mathbf{X} can be replaced by the transposition of matrix \mathbf{Y} ; this simplifies the computation process. Therefore we can rewrite (28) in the form:

$$\boldsymbol{\eta}(0) = \mathbf{Y}^T\mathbf{x}(0) \quad (29)$$

After determining the modal coordinates by means of (27), the solution of the system (9) can be obtained using the linear transformation given by (22).

IV. SIMULATION RESULTS

The previously described model has been used for simulating the dynamic behavior of the belt transmission shown in Fig. 1 during startup. To perform the simulations, it was assumed that the DC motor was controlled with a voltage signal having the following exponential form:

$$V(t) = V_{max}(1 - e^{-t/\gamma}) \quad (30)$$

where V_{max} and γ indicate, respectively, the maximum value of the voltage command and the time constant of the exponential function. The complete list of parameters used for the calculation is shown in Table I.

In order to solve the differential equations, the method of modal analysis in state space has been employed, using numerical techniques [7] for solving the eigenvalue-eigenvector problems and for calculating the integral in (27).

TABLE I
SYSTEM PARAMETERS USED FOR NUMERICAL SIMULATIONS

$J_m = 4 \times 10^{-4} \text{ kgm}^2$	$\tau_{r0} = 0 \text{ Nm}$
$J_1 = 0.018 \text{ kgm}^2$	$\mu = 5 \text{ Nms/rad}$
$J_2 = 0.25 \text{ kgm}^2$	$z = 15$
$k = 120 \text{ kN/m}$	$V_{max} = 24 \text{ V}$
$c = 20 \text{ Ns/m}$	$R = 0.15 \Omega$
$r_1 = 80 \text{ mm}$	$L = 0.2 \text{ mH}$
$r_2 = 160 \text{ mm}$	$k_m = 0.09 \text{ Nm/A}$

The exactness of the results has been verified by comparing the solution obtained by modal approach with the solution resulting from the numerical integration of the system equations (9); the numerical computation has been performed using the fourth order Runge-Kutta method, with step size $\Delta t = 0.1 \text{ ms}$.

Fig. 3 show the time histories of the following variables: motor armature voltage (Fig. 3a), armature current (Fig. 3b), electric and mechanical power (Fig. 3c, d), angular velocity of the pulleys (Fig. 3e, f), angular acceleration of the pulleys (Fig. 3g, h).

The plots have been calculated for three different values of the time constant ($\gamma_1 = 20 \text{ ms}$, $\gamma_2 = 40 \text{ ms}$, $\gamma_3 = 60 \text{ ms}$), using a maximum motor voltage $V_{max} = 24 \text{ V}$.

The numerical simulations here presented show that the mathematical model of the belt transmission can be used during the design stage to simulate with good reliability the dynamic phenomena occurring during the system startup; clearly it is necessary to carry out the validation of the model by means of experimental activity, especially as regards the determination of the damping parameters of the system. The identification of the system parameters represents an interesting perspective of research that could be developed in the future through the use of an instrumented test rig, which allows the user to detect by experiments the most important physical parameters (motor voltage and current, driving torque, angular velocity and angular acceleration of the pulleys), that are necessary for the model validation.

V. CONCLUSIONS

The paper presented the dynamic analysis during startup of a synchronous belt drive with non-negligible elasticity. The study was carried out through the formulation of a mathematical model which considers also the electrical response of the DC motor. To simplify the system modeling, a matrix approach in the state space was used.

As regards the mechanical aspects, the analysis was carried out with the traditional Lagrangian method; for the 2 DOF system under consideration, this method allowed to write a system of two second order linear differential equations with constant coefficients. The addition of (7) required the insertion of a row and a column in the state matrix.

To simulate the system dynamics the modal approach in the state space was used, which allowed to decouple the equations and to obtain the solution of the problem in analytical terms.

The results obtained by this method are in agreement with those obtained by Runge-Kutta algorithm, which, although of easier application, allows only a numerical evaluation of the solution.

The proposed method has been implemented in a software package and it can be easily extended to the study of similar systems with lumped parameters, where the vibrations are due to the compliance of the mechanical components (belt, joints, etc.); in general, assuming that the system under considerations has n degrees of freedom, its description in the state space will require the use of $2n + 1$ variables, since, in addition to the mechanical coordinates, it is necessary to add the current flowing in the armature circuit of the electric motor.

APPENDIX A RIGHT AND LEFT EIGENVECTORS

The denominations *right eigenvalues* and *left eigenvalues* are due to the position of the eigenvectors relative to the matrix \mathbf{A} . In fact, looking at the first member of the equation (16) we note that the eigenvector \mathbf{x} is to the right of \mathbf{A} ;

Considering instead the equation (17) and calculating the transpose of both members, we get: $\mathbf{y}^T \mathbf{A} = \lambda \mathbf{y}^T$. The first member of the equation thus obtained clearly shows that the eigenvector \mathbf{y} (in transposed form) is located to the left of the matrix \mathbf{A} . In Linear Algebra the eigenvalue problem for \mathbf{A}^T is called the *adjoint eigenvalue problem* and the eigenvectors \mathbf{y}_j , $j = 1, \dots, 5$ are known as *adjoint eigenvectors* of the eigenvectors \mathbf{x}_i , $i = 1, \dots, 5$.

APPENDIX B PROOF OF EQUATIONS (20)

To give a proof of (20), we begin by rewriting (16) for the generic right eigenvector \mathbf{x}_i and (17) for the generic left eigenvector \mathbf{y}_j :

$$\mathbf{A} \mathbf{x}_i = \lambda_i \mathbf{x}_i \quad \mathbf{A}^T \mathbf{y}_j = \lambda_j \mathbf{y}_j \quad (31)$$

Considering the second of (31) and transposing both members we get:

$$\mathbf{y}_j^T \mathbf{A} = \lambda_j \mathbf{y}_j^T \quad (32)$$

Pre-multiplying the first of (31) to \mathbf{y}_j^T and post-multiplying (32) to \mathbf{x}_i , we obtain:

$$\mathbf{y}_j^T \mathbf{A} \mathbf{x}_i = \lambda_i \mathbf{y}_j^T \mathbf{x}_i \quad \mathbf{y}_j^T \mathbf{A} \mathbf{x}_i = \lambda_j \mathbf{y}_j^T \mathbf{x}_i \quad (33)$$

Subtracting the second of the (33) from the first, we have:

$$(\lambda_i - \lambda_j) \mathbf{y}_j^T \mathbf{x}_i = 0 \quad (34)$$

If $i \neq j$, the eigenvalues λ_i and λ_j are distinct and thus their difference is not null; therefore from (34) we deduce that:

$$\mathbf{y}_j^T \mathbf{x}_i = 0 \quad i, j = 1, \dots, 5 \quad (35)$$

Equation (35) states that, for a given matrix \mathbf{A} and for $\lambda_i \neq \lambda_j$, the right eigenvectors \mathbf{x}_i are orthogonal to the left eigenvectors \mathbf{y}_j .

Substituting (35) into the first or second of the (33) we get:

$$\mathbf{y}_j^T \mathbf{A} \mathbf{x}_i = 0 \quad i, j = 1, \dots, 5 \quad (36)$$

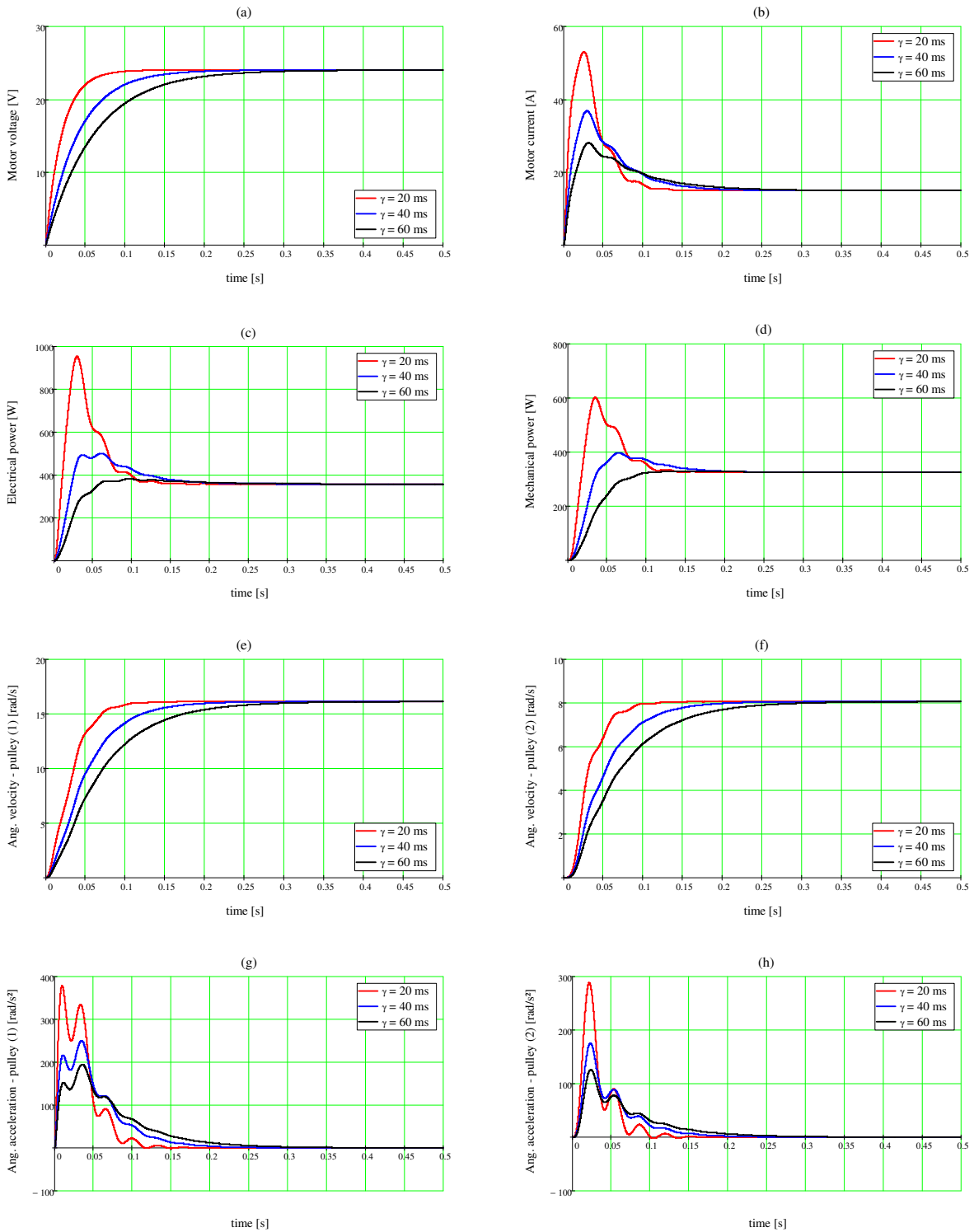

Fig. 3. Simulation results: a) Motor voltage (command signal); b) Armature current; c) Electric power at the motor terminals; d) Mechanical power at the motor shaft; e) Angular velocity $\dot{\theta}_1$; f) Angular velocity $\dot{\theta}_2$; g) Angular acceleration $\ddot{\theta}_1$; h) Angular acceleration $\ddot{\theta}_2$.

This relationship shows that the eigenvectors \mathbf{x}_i and \mathbf{y}_j are orthogonal also with respect to the state matrix \mathbf{A} .

For $i = j$ we obtain from (33) the following result:

$$\mathbf{y}_i^T \mathbf{A} \mathbf{x}_i = \lambda_i \mathbf{y}_i^T \mathbf{x}_i \quad i = 1, \dots, 5 \quad (37)$$

Generally $\mathbf{y}_i^T \mathbf{x}_i \neq 1$, but, for each pair of eigenvectors $\mathbf{y}_i \in \mathbf{x}_i$ we can always find a normalization coefficient α_i such that:

$$(\alpha_i \mathbf{y}_i^T)(\alpha_i \mathbf{x}_i) = 1 \quad (38)$$

According to this equation the coefficient α_i will be:

$$\alpha_i = \frac{1}{\sqrt{\mathbf{y}_i^T \mathbf{x}_i}} \quad i = 1, \dots, 5 \quad (39)$$

Multiplying by α_i the components of the vectors \mathbf{y}_i and \mathbf{x}_i , we get new normalized eigenvectors which satisfy the relation¹:

$$\mathbf{y}_i^T \mathbf{x}_i = 1 \quad i = 1, \dots, 5 \quad (40)$$

According to (40), we rewrite (37) in the form:

$$\mathbf{y}_i^T \mathbf{A} \mathbf{x}_i = \lambda_i \quad i = 1, \dots, 5 \quad (41)$$

Using the matrices defined by (19), considering the orthogonality property (35) and taking into account the normalization condition (40), we can write:

$$\mathbf{Y}^T \mathbf{X} = \mathbf{I} \quad (42)$$

Finally, from (41) we have:

$$\mathbf{Y}^T \mathbf{A} \mathbf{X} = \mathbf{\Lambda} \quad (43)$$

where $\mathbf{\Lambda}$ is defined by (21).

APPENDIX C LIST OF SYMBOLS

Pulley (1) rotation angle	ϑ_1
Pulley (2) rotation angle	ϑ_2
Motor shaft rotation angle	ϑ_m
Kinetic energy	T
Potential energy due to system elasticity	U
Rayleigh dissipation function	D
Work done by motor and resistant torques	W
Motor torque	τ_m
Load torque	τ_r
Constant component of the load torque	τ_{r0}
Viscous friction coefficient	μ
Moment of inertia of the motor	J_m
Moment of inertia of pulley (1)	J_1
Moment of inertia of pulley (2)	J_2
Axial stiffness of the belt branches	k
Damping constants of the belt branches	c
Pulley (1) radius	r_1
Pulley (2) radius	r_2
Gear ratio	z
Armature voltage of the DC servomotor	V
Maximum armature voltage	V_{max}
Armature current	I
Armature resistance	R
Armature inductance	L
Torque/back e.m.f. costante fo the DC motor	k_m
Time constant of the exp. function (used as command voltage)	γ

¹For convenience, the new normalized eigenvectors are indicated with the same symbols $\mathbf{y}_i \in \mathbf{x}_i$ used for the non-normalized eigenvectors.

REFERENCES

- [1] Iwatsubo T., Hasegawa K., Arii S., Shiohata K., "The Formulation and Dynamic Analysis of a Multiple Belt System", *Journal of Sound and Vibration*, 205(3), 293-307 (1997).
- [2] Lee K.M., Rutherford C., "Frequency reshaped quadratic control of a low-cost human level performance belt-driven robot", *Mechatronics*, 9, 95-110 (1999).
- [3] Al-Dwairi A.F., Al-Lubani S.E., "Modeling and dynamic analysis of a planetary mechanism with an elastic belt", *Mechanism and Machine Theory* 39, 343-355 (2004).
- [4] Kelly S.G., "Mechanical Vibrations - Theory and applications", Cengage Learning (2012).
- [5] Krämer E., *Dinamica delle macchine - Calcolo delle Vibrazioni*, Traduzione italiana a cura di A. Barozzi, Pitagora Editrice (1995).
- [6] Meirovich L., *Fundamentals of Vibrations*, McGraw-Hill Higher Education (2001).
- [7] Press W.H., Teukolsky S.A., Vetterling W.T., Flannery B.P., *Numerical Recipes in C*, Cambridge University Press (1992).



Giovanni Incerti graduated in Mechanical Engineering in 1990 at the University of Brescia, Italy. At the same university he received the Ph.D in Applied Mechanics in 1995. Actually he is associate professor at the University of Brescia and his teaching activity is related to the courses of Mechanical Vibrations, Applied Mechanics and Vibration Control. He is author of papers dealing with the dynamic analysis of cam systems, the mathematical modeling of devices for industrial automation, the mechanism design by optimization techniques and the study of robots and servomechanisms. He took part in researches funded by the Italian Council of Researches (CNR) and by the Italian Ministry of University and Research. Recently he has been scientific coordinator for the University of Brescia inside the National research project *Design and experimental validation of cam transmissions*.