

A Maximum Power Point Tracker for PV Panels Using SEPIC Converter

S. Ganesh, J. Janani, G. Besliya Angel

Abstract—Photovoltaic (PV) energy is one of the most important renewable energy sources. Maximum Power Point Tracking (MPPT) techniques should be used in photovoltaic systems to maximize the PV panel output power by tracking continuously the maximum power point which depends on panel's temperature and on irradiance conditions. Incremental conductance control method has been used as MPPT algorithm. The methodology is based on connecting a pulse width modulated dc/dc SEPIC converter, which is controlled by a microprocessor based unit. The SEPIC converter is one of the buck-boost converters which maintain the output voltage as constant irrespective of the solar isolation level. By adjusting the switching frequency of the converter the maximum power point has been achieved. The main difference between the method used in the proposed MPPT systems and other technique used in the past is that PV array output power is used to directly control the dc/dc converter thus reducing the complexity of the system. The resulting system has high efficiency, low cost and can be easily modified. The tracking capability has been verified experimentally with a 10 W solar panel under a controlled experimental setup. The SEPIC converter and their control strategies has been analyzed and simulated using Simulink/Matlab software.

Keywords—Maximum Power Point Tracking, Microprocessor, PV Module, SEPIC Converter.

I. INTRODUCTION

SOLAR panel is the fundamental energy conversion component of photovoltaic (PV) systems. It has been used in many applications, such as aerospace industries, electric vehicles, communication equipment, etc. As the solar panels are relatively expensive, much research work has been conducted to improve the utilization of solar energy. Physically, the power supplied by the panels depends on many extrinsic factors, such as insolation (incident solar radiation) levels, temperature, and load condition. Thus, a solar panel is typically rated at an insolation level together with a specified temperature, such as 1000 W/m at 25C. Its electrical power output usually increases linearly with the insolation and decreases with the cell/ambient temperature.

In practice there are three major approaches for maximizing power extraction in medium- and large-scale systems. They are maximum power point tracking, sun tracking and combination of both.

For small-scale systems, MPPT is popular for economical reasons. The various methods used for MPPT are as follows:

1. Power matching scheme [1]
2. Curve-fitting technique (hill climbing method) [2]

S. Ganesh is with the Department of Electrical and Electronics Engineering, Chandy College of Engineering, Thoothukudi, Anna University, Chennai, Tamil Nadu, India (e-mail: gauti.ganeshs@gmail.com).

3. Perturb-and-observe method [3]
4. Incremental conductance technique [4]

A. Curve-Fitting Technique

The curve-fitting technique requires prior examination of the solar panel characteristics, so that an explicit mathematical function for describing the output characteristics is formulated. Although this technique attempts to track the maximum power point without computing the voltage-current product explicitly for the panel power, the curve-fitting technique cannot predict the characteristics including other complex factors, such as aging, temperature, and a possible breakdown of individual cells [2].

B. Perturb-and-Observe (PAO) Method

The perturb-and-observe (PAO) method is an iterative approach that perturbs the operation point of the PV system, in order to find the direction of change for maximizing the power. Maximum power control is achieved by forcing the derivative of the power equal to zero under power feedback control. This has an advantage of not requiring the solar panel characteristics. However, this approach is unsuitable for applications in rapidly changing atmospheric conditions [3].

C. Incremental Conductance Technique (ICT)

The disadvantage of the PAO method can be improved by comparing the instantaneous panel conductance with the incremental panel conductance. This incremental conductance technique is the most accurate one among the other methods. The input impedance of a switching converter is adjusted to a value that can match the optimum impedance of the connected PV panel. This technique gives a good performance under rapidly changing conditions. However, the implementation is usually associated with a microcomputer or digital signal processor that usually increases the whole system cost [4].

This paper focuses on SEPIC dc-dc converter as voltage level control using Incremental conductance MPPT systems.

According to maximum power transfer theorem, the power output of a circuit is maximum when the source impedance matches with the load impedance. Hence the problem of tracking the maximum power point reduces to an impedance matching problem. In the source side a boost converter is connected to a solar panel in order to enhance the output voltage. It can be used for motor load applications. By changing the duty cycle of the boost converter appropriately, the source impedance can be matched with that of the load impedance. The power-matching scheme requires the selected solar panels to have suitable output characteristics or configurations that can be matched with particular loads. It

only approximates the location of the MPP because they are basically associated with specific insolation and load conditions.

II. PROPOSED SYSTEM

The solar power which can be obtained from solar cell cannot be utilized directly. It is usually stored in the battery and inverter circuit and further it can be used as AC. But the output voltage as well as power from the solar cell depends upon the illumination and intensity of the light. If the light intensity is very low it may produce very low output voltage. The lower output voltage from the solar cell may not charge the battery and the power is wasted. Here an intermediate stage of converter called SEPIC is used to boost the lower output voltage from the solar cell and also buck the voltage if the light intensity is high. The block diagram of proposed system is shown in Fig. 1.

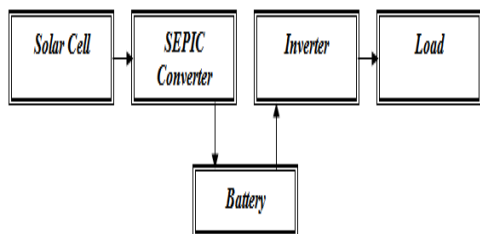

Fig. 1 Block diagram of proposed system

A DC-DC converter with simpler structure and higher efficiency has been an active research topic in the power electronics. A SEPIC is similar to a traditional buck-boost converter, but has advantages of having non-inverted output. Non-inverting buck-boost topologies require more active components. SEPICs are useful in applications in which a battery voltage can be above and below that of the regulator's intended output. In this proposed system, a prototype SEPIC converter is designed to Charge the battery from the solar panel.

In solar cells, a number of PV modules are arranged in series and parallel to meet the energy requirements.

Solar cells have a complex relationship between solar irradiation, temperature and total resistance that produces a non-linear output efficiency which can be analyzed based on the I-V curve. It is the purpose of the MPPT system to sample the output of the cells and apply the proper resistance (load) to obtain maximum power for any given environmental conditions. MPPT devices are typically integrated into an electric power converter system that provides voltage or current conversion, filtering, and regulation for driving various loads, including power grids, batteries, or motors. Fig. 2 shows the single diode model of PV cell [5].

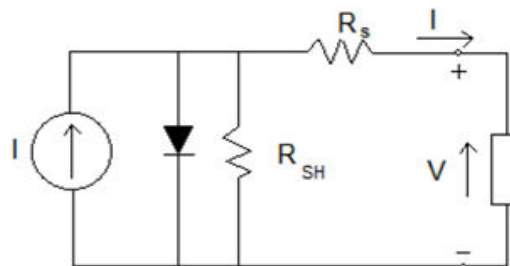

Fig. 2 Single diode model of PV cell

where I is the current source, R_s is the series resistance and R_{SH} is the shunt resistance. R_{SH} is very high compared with R_s and has a negligible effect in the output current. The output current from the photovoltaic array is

$$I = I_{sc} - I_d \tag{1}$$

$$I_d = I_o (e^{qV_d/kT} - 1) \tag{2}$$

where I_o is the reverse saturation current of the diode, q is the electron charge, V_d is the voltage across the diode, k is Boltzmann constant (1.38 * 10⁻¹⁹ J/K) and T is the junction temperature in Kelvin (K).

$$I = I_{sc} - I_o (e^{qV_d/kT} - 1) \tag{3}$$

Using suitable approximations,

$$I = I_{sc} - I_o (e^{q((V + IR_s)/nkT)} - 1) \tag{4}$$

where, I is the photovoltaic cell current, V is the PV cell voltage, T is the temperature (in Kelvin) and n is the diode ideality factor. In order to model the solar panel accurately two diode model is used. In this paper the scope of study is limited to the single diode model. Also, the shunt resistance is very high and can be neglected during the course of our study.

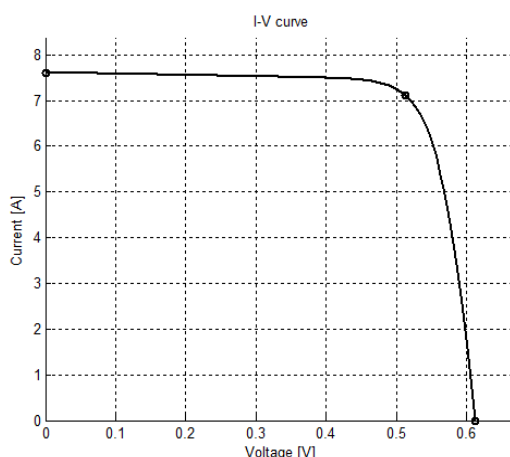

Fig. 3 VI characteristics of solar cell

The VI characteristics of a typical solar cell are as shown in Fig. 3. The PV characteristics are obtained by the voltage and the current characteristics as shown in below Fig. 4. The point indicated as MPPT is the point at which the panel power output is maximum.

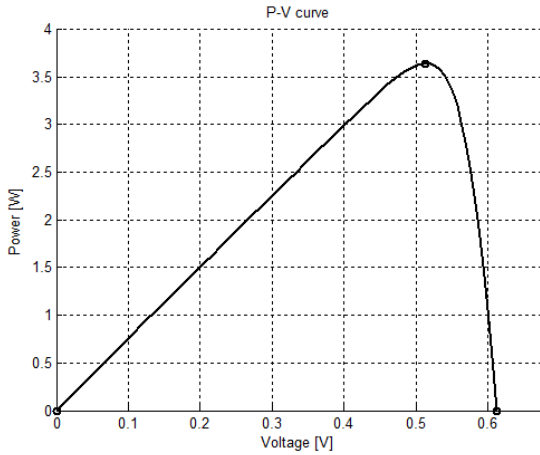

Fig. 4 P-V characteristics of solar cell

III. ANALYSIS OF SEPIC CONVERTER

The single-ended primary-inductor converter (SEPIC) is capable of operating from an input voltage that is greater or less than the regulated output voltage. Aside from being able to function as both a buck and boost converter, the SEPIC also has minimal active components, a simple controller, and clamped switching waveforms that provide low noise operation.

A. MPPT Using SEPIC

A novel technique for efficiently maximizing the output power of a solar panel supplying to a load or battery bus under varying meteorological conditions is presented. The power conversion stage (PCS), which is connected between a solar panel and a load or battery bus, is a pulse width-modulated (PWM) dc/dc SEPIC converter or their derived circuits operating in discontinuous inductor current mode (DICM) or capacitor voltage mode (DCVM).

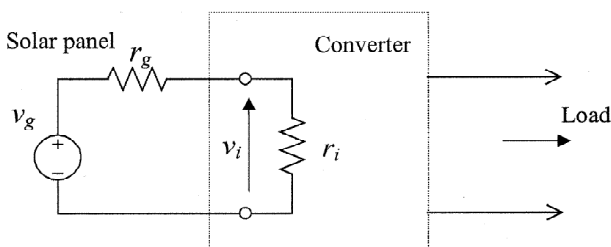

Fig. 5 Equivalent circuit of a solar panel connecting to a converter

Fig. 5 shows an equivalent circuit of the solar panel connecting to a converter [6]. The equivalent circuit for solar panels generally consists of a current source shunted by a diode and a resistor and with an output series resistor.

However, a Thevenin's equivalent circuit is used to represent the solar panel at the maximum power point in this case. The solar panel is represented by a voltage source connecting in series with an output resistance. The input voltage and the equivalent input resistance of the converter are given below. As the input power P_i to the converter is equal to the output power P_o of the solar panel.

$$P_i = P_o = V_i^2 / R_i \tag{6}$$

The rate of change of with respect to and can be shown to be

$$\partial P_i = (2 \left(\frac{V_i}{R_i}\right) * \partial V_i) - \left(\frac{V_i^2}{R_i^2}\right) * \partial R_i \tag{7}$$

At MPPT, the rate of change of power is zero and (7) becomes,

$$\partial P_i = 0 \implies \frac{\partial V_i}{\partial R_i} = \frac{V_i}{2R_i} \tag{8}$$

This type of converter is found to have the input resistance characteristics being proportional or inversely proportional to the switching frequency. Hence, by adjusting the nominal duty cycle of the main switch in the converter, the input resistance of the converter can be made equal to the equivalent output resistance of the panel. This operation ensures the maximum power transfer. By modulating a small-signal sinusoidal perturbation into the switching frequency of the main switch and comparing the ac component and average value of the panel terminal voltage, the MPPT can be located. The tracking capability of the proposed technique has been verified experimentally with a 10 W solar cell panel at different insolation levels and temperatures, and under different large-signal insolation changes. SEPIC type converter is used in this study as DC/DC converter of the MPPT system. The SEPIC converter circuit is shown in Fig. 6.

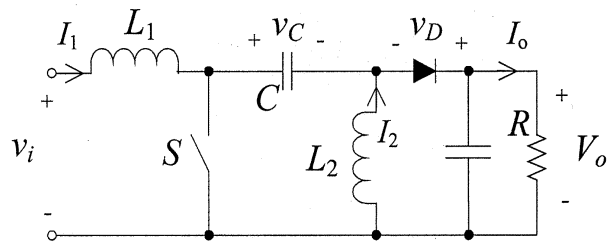

Fig. 6 Circuit diagram of a SEPIC converter

IV. TEST SYSTEM

A. SEPIC Converter (Hardware Diagram)

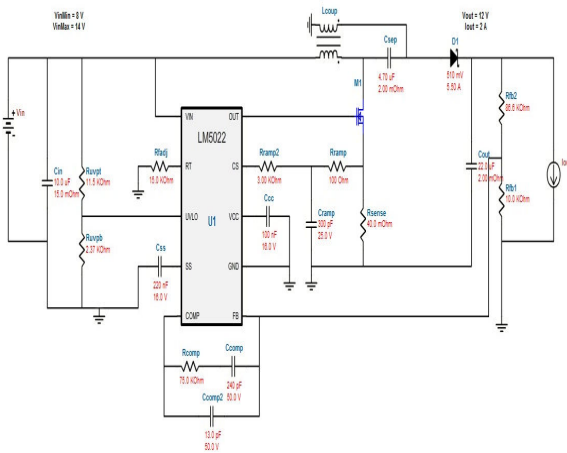

Fig. 7 Hardware Diagram of SEPIC Converter

Fig. 7 shows the hardware diagram of SEPIC converter. Here R_{uvpt} and R_{uvpb} are used to sense the input current. R_{fb1} and R_{fb2} are used to sense the output current. R_{sense} is used to sense the switching current. The value of R_{sense} is 40 ohm. R_{comp} , C_{comp} and C_{comp2} are provided feedback path. Voltage and current ratings are shown in Table I.

TABLE I
VOLTAGE AND CURRENT RATING

$V_{in} Min(V)$	$V_{in} Max(V)$	$V_{out}(V)$	$I_{out}(A)$
8.0V	14.0V	12.0V	2.0A

The voltage regulation of 12V is achieved for an input voltage of 8V to 14V. For various input voltage level efficiency and duty cycle Vs I_{out} curve shown in Fig. 8.

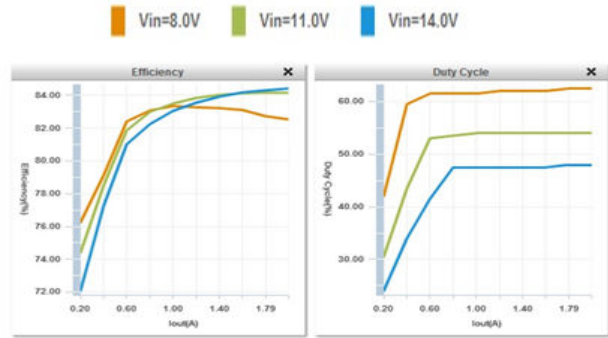

Fig. 8 Efficiency and Duty cycle for different input voltages

The perfect DC-DC converter would be one where none of the incoming DC energy is wasted in the converter; it would all end up converted and fed to the output. Inevitably practical converters have losses voltage drops due to resistance in the inductor or transformer windings, on resistance in the MOSFETs, forward voltage drop in the rectifier diodes, eddy current and hysteresis losses in the inductor or transformer, and so on. It's the job of the converter designer to reduce all of these losses to the lowest possible level, to make the converter as efficient as possible. You may have wondered, for example, MOSFETs used as switches in most of the converter circuits. That's because modern MOSFETs make the most efficient electronic switches of high DC currents. When the switch is turned OFF it is virtually an open circuit, and when the switch is turned ON it act as a short circuit. Under short circuit conditions, the resistance is minimum and the power loss is minimized. For the same reason, the diodes used in most modern DC-DC converters are of the Schottky or hot carrier metal-semiconductor junction type. These have a significantly lower forward voltage drop than silicon diodes, and hence power loss is negligible.

B. Simulation Model for Open Loop Control

MATLAB is an interactive, matrix-based package for scientific and engineering graphical user interface, signal processing, fuzzy logic, and many others. The number optimization, statistics, neural networks, of different toolboxes increases with each newer version of MATLAB numeric computation and visualization. It can solve complex numerical problems in a fraction of the time required. The final simulation model of SEPIC converter is shown in Fig. 9.

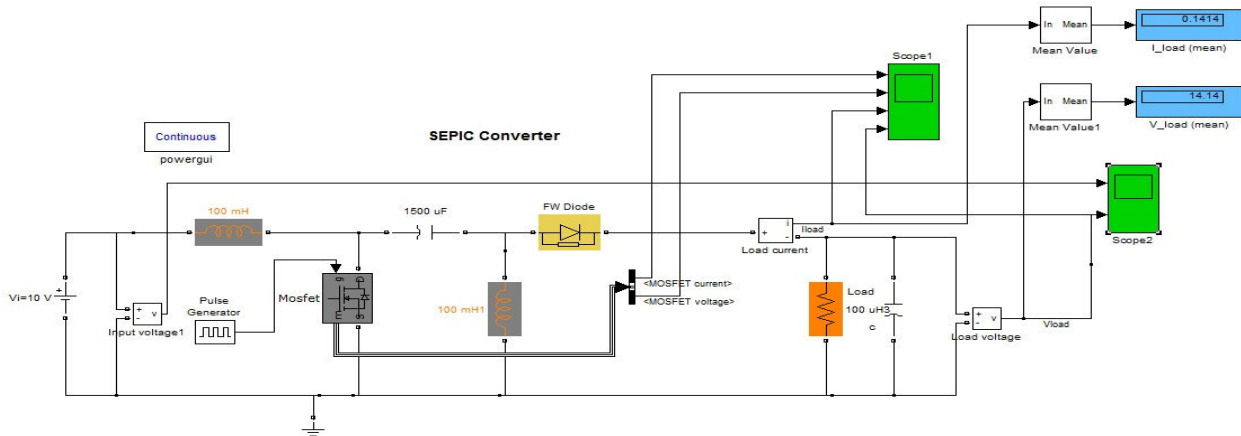

Fig. 9 Simulation of SEPIC Converter

Simulations have been performed to confirm the above analysis. Figs. 9 and 10 show the Simulation of open loop SEPIC Converter and simulation result of SEPIC Converter. Table II shows the simulation input and output parameters.

TABLE II
SIMULATION PARAMETERS

DC input voltage	L1	L2	C1	C2	Duty cycle	Output voltage
10V	200e-3H	500e-6H	37e-6F	1000e-6F	54%	15V

(different radiation levels) and an inverter circuit of 40 W. MATLAB/Simulink software has been used to simulate SEPIC converter. Compared to many existing methods, the proposed technique is unnecessary to

1. Perform digital sampling of the converter parameters.
2. Perform sophisticated mathematical computations of the panel output power.
3. Approximate the panel output characteristics.

Hence, it can be used under a wide range of meteorological conditions.

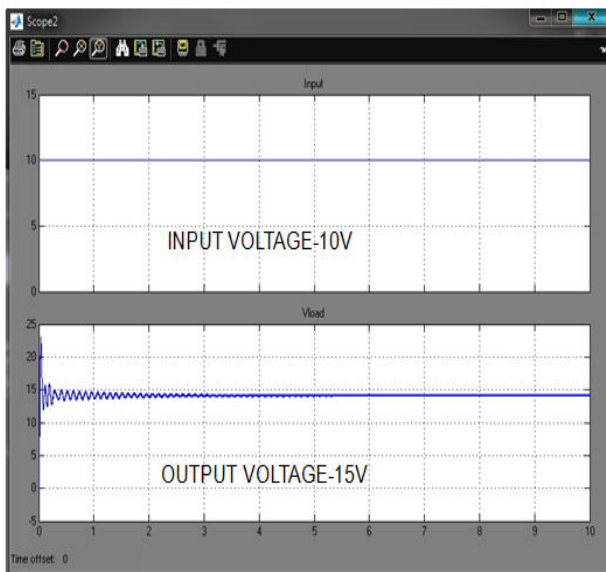

Fig. 10 Simulation Result of SEPIC Converter

V. CONCLUSION

A novel technique using a SEPIC converter to efficiently track the maximum power point of a solar panel has been presented. The technique is simple and elegant and does not require complicated mathematical computation. The tracking capability of the proposed technique has been verified experimentally with a 12V, 2A converter with input voltages

REFERENCES

- [1] A. Braunstein and Z. Zinger, "On the dynamic optimal coupling of a solar cell array to a load and storage batteries," *IEEE Trans. Power Apparatus Syst.*, vol. 100, pp. 1183–1188, 1981.
- [2] A. Kislovski and R. Redl, "Maximum-power-tracking using positive feedback," in *Proc. IEEE Power Electron. Spec. Conf.*, 1994, pp. 1065–1068.
- [3] J. Gow and C. Manning, "Controller arrangement for boost converters systems sourced from solar photovoltaic arrays or other maximum power sources," *Proc. Inst. Elect. Eng.*, vol. 147, no. 1, pp. 15–20, Jan. 2000.
- [4] A. Nafeh, F. Fahmy, O. Mahgoub, and E. Abou El-Zahab, "Microprocessor control system for maximum power operation of PV arrays," *Int. J. Numer. Model.*, vol. 12, pp. 187–195, 1999.
- [5] H.S Hung Chung, K.K.Tse "a novel maximum power point tracking technique for a solar panels using a SEPIC or CUK converter." *IEEE Trans power Electronic* vol.18 no.3 may 2003.
- [6] K.Ktse. S.h Chung "A Novel Maximum Power Point Tracker For PV panels using Switching frequency Modulation" *IEEE Trans on power electronics* vol 17 no 6 Nov 2002.

S. Ganesh obtained his B.E. in Electrical and Electronics Engineering in Dr. Sivanthi Adithanar College of Engineering Tiruchendur, Anna University, Tamilnadu, India, in 2009 and did his Master of Engineering (Power Systems Engineering) in St. Joseph's Engineering College, Anna University, India, in 2013.

He is working as an Assistant Professor in the department of Electrical and Electronics Engineering, Chandy College of Engineering, Thoothukudi, Tamilnadu, India.

J. Janani received the B.E degree in Electrical and Electronics Engineering from PSR College of Engineering, Sivakasi, Anna University, Tamilnadu, India, in 2013 and she is doing Master of Engineering (Power Systems Engineering) in Chandy College of Engineering, Thoothukudi, Tamilnadu, India.

G. Besliya Angel received the B.E degree in Electrical and Electronics Engineering from VOC College of Engineering, Thoothukudi, Anna University, Tamilnadu, India, in 2013 and she is doing Master of Engineering (Power Systems Engineering in Chandy College of Engineering, Thoothukudi, Tamilnadu, India.