

A Framework and Case Study for Sustainable Development of Urban Areas

Yasaman Zeinali, Farid Khosravikia

Abstract—This paper presents a multi-objective framework for sustainable urban development. The proposed framework aims to address different aspects of sustainability in urban development planning. These aspects include, but are not limited to education, health, job opportunities, architecture, culture, environment, mobility, energy, water, waste, and so on. Then, the proposed framework is applied to the Brackenridge Tract (an area in downtown Austin, Texas), to redevelop that area in a sustainable way. The detail of the implementation process is presented in this paper. The ultimate goal of this paper is to develop a sustainable area in downtown Austin with ensuring that it locally meets the needs of present and future generations with respect to economic, social, environmental, health as well as cultural aspects. Moreover, it helps the city with the population growth problem by accommodating more people in that area.

Keywords—Environmental impacts of human activities, sustainability, urban planning.

I. INTRODUCTION

THIS paper puts forward a framework to achieve a sustainable urban development. According to [1], a sustainable development is an innovative development in which information, communication technologies, and other tools are used to improve the quality of life as well as the productivity of the urban systems and services, while meeting the demands of current and future generation in terms of economic, environmental, social, and culture aspects. In the literature, many studies aimed to achieve such a development using different methodologies and concepts for different areas such as Kutahya [2], Milan [3], Berlin [4], and other areas of Europe [5], [6].

The present study proposes a multi-objective framework, shown in Fig. 1, to address different aspects of sustainability at different steps. As seen in the figure, the first step is the population density of the development, which is defined as the number people per square mile. In fact, the very beginning step is to determine the target population density of the development to make sure that it provides the appropriate density of residents and buildings. The data for demographic distribution of the population density over the entire city at the current condition and its estimated value in the future are key factors in determining the target population density. Moreover,

Farid Khosravikia is with the Department of Civil, Architectural, and Environmental Engineering of The University of Texas at Austin, Austin, TX 78758, USA (corresponding author phone: 512-662-2478; e-mail: farid.khosravikia@utexas.edu).

Yasaman Zeinali was with the Department of Civil, Architectural, and Environmental Engineering of The University of Texas at Austin, Austin, TX 78758, USA (phone: 512-662-2447; e-mail: Yasaman.zeinali@utexas.edu).

in areas with significant population growth, it is important to make sure that the development will accommodate the proper amount of people to prevent from urban sprawl problems.

The second step in the proposed framework is to ensure that all the basic demands of the residents such as jobs, health, education, sports, and culture, are going to be locally addressed. To do so, different areas of land should be assigned for different types of land use to address the resident's demands. To ensure that this will happen in a proper way, land use evaluation is introduced here.

The third step is to ensure that the investment and development will result in reasonable economic benefits for the investors. To do so, cost-benefit analysis, Net Present Value (NPV) and benefit-cost ratio of the development are evaluated at this step. In addition, the present study proposes a disaggregated demonstration of NPV to discuss the contribution of each development in NPV, which will be discussed shortly.

The fourth step is to address the sustainable features at design level. This step contains urban planning, architectural, and social aspects of the sustainability.

The fifth step of the framework addresses the environmental aspects of the sustainability, climate and ecology. Healthy ecosystems provide vital goods and services to humans and other organisms. The proposed framework aims to reduce negative human impact and enhance ecosystem services.

Then, the sustainability in the mobility is addressed. Sustainability in mobility, in this context, is defined as the broad subject of transport that is sustainable in the scenes of social, environmental and climate impacts and the ability to, in the global scope, supply the source energy indefinitely.

Finally, the framework considers the sustainability in the system-level facilities including energy, water, and waste. Sustainable energy, here, is defined as an energy form that meets current demands without threatening future generations with the danger of expiring or depleting the energy resources. Moreover, the proposed framework proposes some practical techniques to reduce the energy and water consumptions as well as waste generation. The framework also takes into account the interdependencies among these systems.

The proposed framework is implemented in developing a sustainable area in Brackenridge Tract, located in downtown Austin, Texas. The current condition of the considered area is shown in Fig. 2. As seen in this figure, the total area of the tract is approximately 350 acres which includes golf course, Brackenridge field lab, Brackenridge apartments, Colorado apartments, Waya, Deep Eddy Tract, Park Street, Safeway, and Boat town.

In the following sections, first, the master plan proposed for the considered areas is going to be introduced. Then, the application of the framework in the proposed plan is going to be discussed. In particular, it will be investigated how

different steps of the proposed framework can be implemented in the considered area and how such a framework can result in a sustainable development.

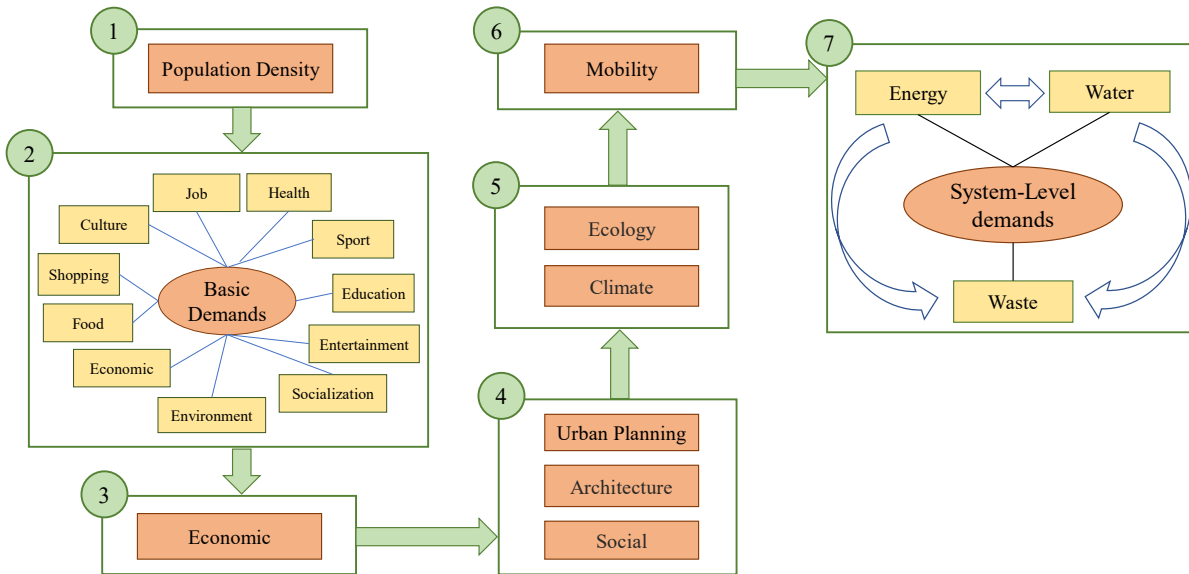

Fig. 1 Proposed flow chart for sustainable urban development

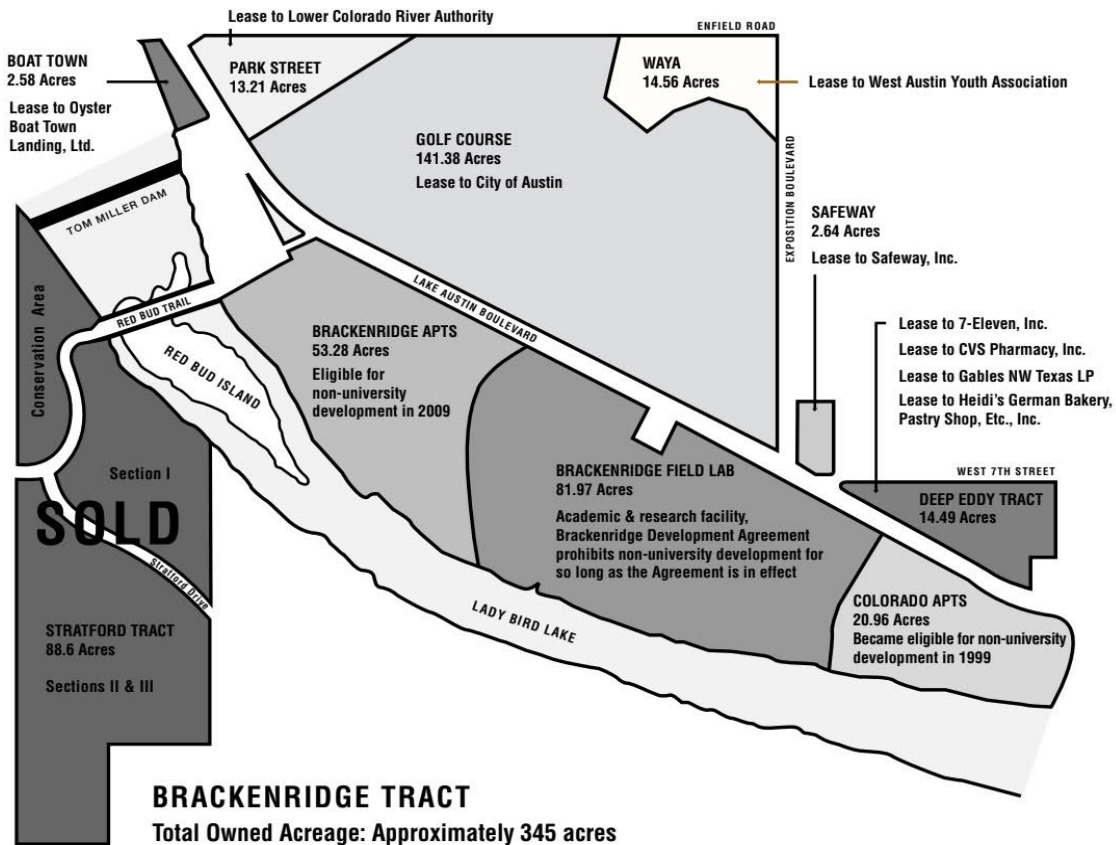

Fig. 2 Current condition of Brackenridge tract

II. PROPOSED MASTER PLAN

Fig. 3 shows the master plan proposed for the considered area. This master plan is derived from all the steps of the proposed framework. In the following, different parts of the master plan and the implementation of each step in the development will be discussed in details.

III. TARGET DENSITY

The first step is to determine the target density of the development. Population density, here, is defined as the number of people per square mile. For instance, the density of Manhattan area in New York County is 72,918 people per square mile in 2018 [7]. However, for Austin, it is a different story. According to [8], the density of Austin in 2010 went up to 25,000 with an average of 3,000 for the whole city. However, this density is estimated to go up to 45,000 for some areas of the city at 2030, which is mainly because of the recent population growth in Austin. Moreover, according to [8], the

average density of the considered area is now approximately 3,000 people per square mile.

As seen in Fig. 4, it is decided to set the density of 8,000 as target density for the considered area. In fact, it is decided to increase the current density of the area from 3,000 to 8,000, in preparation for it to help the city accommodate more people to prevent urban sprawl as a result of population growth in Austin. Moreover, it reduces the rent prices in downtown area by providing more apartments. Right now, there are less residential buildings compared to the demand in the downtown area, which increases the rent prices in that area. However, adding more buildings (increasing the capacity) helps with the prices. Moreover, it is still less than more densely populated areas of the city such as part of the downtown area and areas close to UT, which has a density of 22,000 to ensure that the development will not result in a too densely populated area.

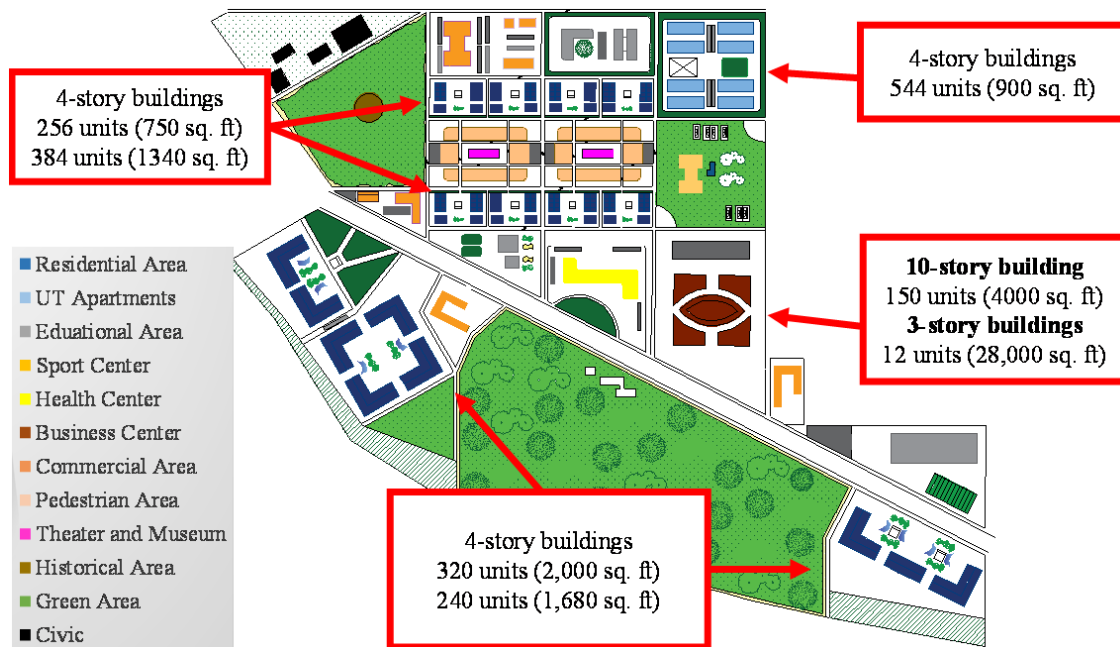

Fig. 3 Proposed plan for Brackenridge tract

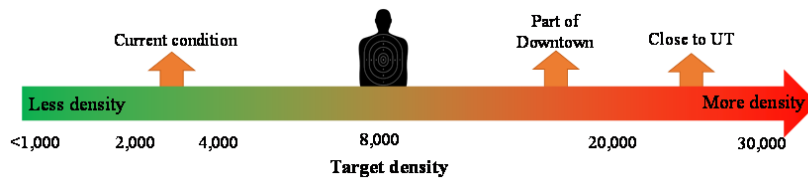

Fig. 4 Current and target population density

To achieve the target density, the master plan provides different types of apartments for 4,278 people. To do so, 30% of the land is assigned for residential and UT apartments. Fig. 3 shows the location of residential areas in the development. As seen in the figure, they are 4-story buildings with different

sizes. The first residential area, which contains 256 small size (750 square foot) and 384 moderate size (1340 square foot) apartments, is located close to the pedestrian area for those who want to live in a relatively densely populated area. The second residential area is the area close to the river, which is

the more valuable part of the development. This area is assigned for people who want to live in a quiet place, and it generally consists of larger apartments compared to those close to the pedestrian area. In particular, this area will consist of 320 moderate size (1,680 square foot) and 240 larger size (2,000 square foot) apartments.

Finally, as seen in the figure, 544 units with floor size of 900 square foot are considered for the UT apartments, which aim to accommodate approximately 1,080 graduate students. In fact, the development aims to provide the same capacity of UT apartments as the current condition. The main reason of keeping the UT apartments there is that, as seen in Fig. 4, the areas close to the main campus of the local university have already been densely populated, and generally have population densities over 20,000. Thus, it should be difficult for UT to move those students to areas closer to the main campus. Moreover, UT apartments have approximately a 2.5-year-long waiting list, which indicates that there is a huge need of increasing the capacity of UT apartments, and it is not favorable to reduce the capacity with this development. However, the apartments are relocated from the more valuable side to the area closer to main campus. The main reasons of this relocation are as follows: First, this relocation reduces travel time from UT apartment to the main campus. It is estimated that with adding a new bus line and using other routes, 6 minutes can be saved in every travel from UT apartments to the main campus. This reduction will help student to save time and help with the energy consumption. Second, this relocation will reduce unnecessary traffic and density from Lake Austin Boulevard. In fact, students will use Enfield road for their travel to main campus. Third, this

relocation places the students closer to the sport center and library. Finally, it helps UT to save money through leasing the more valuable part of the area to residential buildings.

IV. BASIC DEMANDS OF THE RESIDENTS

One of the main goals of this development is to locally address the basic demands of the residents. These demands include but are not limited to living area, education, sport, health, job opportunities, food, entertainment, culture, and green areas. To address these demands, Fig. 5 shows the land use of the proposed plan for Brackenridge tract. Different colors in the figure represent different types of land use. The right plot shows the amount of the area assigned for each type of land use. As seen in the figure, 26% of the area is assigned for residential buildings, 4% is assigned for UT apartments, 8% of the area is assigned to education, which consists of daycare, school, learning center, and library, and 4-6% of the area is assigned for sport, health, and business centers, separately. Then, four different parts of the area (8% in sum) are assigned as the commercial area, which is used for grocery stores, restaurants, post offices, gas stations, haircut salons and so on. Moreover, there is a pedestrian area including 5% of the land for restaurants, coffees, bars, with small shopping centers. No cars are allowed in the area. Approximately, 7% of the land is assigned for historical and cultural activities. This area also consists of community centers for socializing. Finally, approximately 25% of the area is assigned for the green area, and it is decided to keep the civic area with some renovations to improve its performance and reduce energy consumptions.

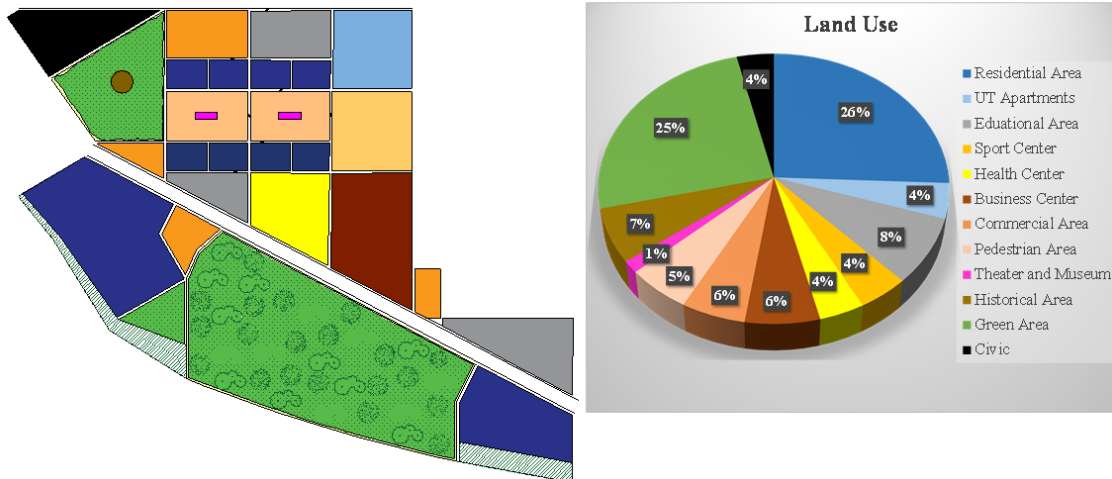

Fig. 5 Land use

One of the key aspects of the sustainable development is to provide diverse and local job opportunities for the people living in that area. Table I shows the job opportunities provided by different types of development in that area. As seen in the table, 4,170 different job opportunities are provided for the residents, the majority of which

(approximately 1,660 jobs) comes from a business center. Fig. 3 demonstrates the location of the business center in the proposed development. The business center consists of a high-rise building (10-story) as well as four 3-story side buildings. In sum, the center provides 150 offices with size of 4,000 square foot and 12 larger offices with size of 28,000 square

foot. This center is also considered to provide offices for new startups and entrepreneurs. This type of consideration will help UT to improve its reputation.

TABLE I
LOCAL JOB OPPORTUNITIES PROVIDED IN THE DEVELOPMENT

Land Type	Job Opportunities
Business Center	1,660
Health Center	700
Commercial Area	590
Pedestrian Area	920
Other	300
Total	4,170

V. ECONOMIC ASPECT OF THE DEVELOPMENT

One of the key features of each development is to make sure that the entire plan has proper economic benefits. In particular, it should be ensured that UT, as the main investor, will benefit from this investment. To address this issue, a cost-benefit analysis is conducted, and the results are shown in Fig. 6. Cost, here, indicates the initial cost as well as those associated with the maintenance, insurance, and taxes. It should be noted that for some developments such as the commercial areas, a triple net lease has been considered in the analysis. A triple net lease, which is most commonly used in commercial buildings, is a lease contract on a property in which lessee or tenant, in addition to normal fees such as rent and utilities, should pay: 1) real estate taxes, 2) building insurance, and 3) maintenance fees. The benefit generally refers to the annual revenue from leasing the facilities developed in that area. As seen in the figure, the development has a payback period of 8 years, which is defined as the length of time required for an investment to recover its initial outlay in terms of profits or savings.

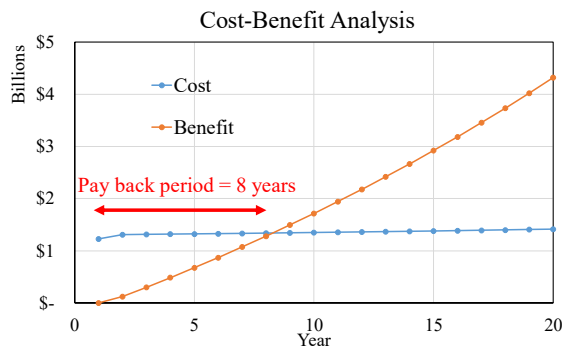

Fig. 6 Cost-benefit analysis of the proposed development

In addition to the cost-benefit analysis, Fig. 7 shows the total initial investment as well as the NPV of the development, which is calculated as (1):

$$NPV = -\text{Initial Cash Investment} + \sum_{t=1}^{20} \frac{\text{Cash Flow}}{(1+i)^t} + \frac{\text{Value after 20 years}}{(1+i)^{20}} \quad (1)$$

where i is the interest rate that is assumed to be 0.03, and the analysis is conducted over 20 years. As seen in Fig. 7, the total initial investment is approximately \$1.2 billion, and the NPV of the development over the 20 years is about \$3.3 billion.

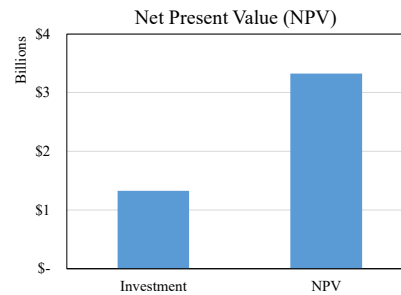

Fig. 7 Investment and NPV of our development

For more detailed information about the NPV, Fig. 8 shows the disaggregated values of NPV for each development. In fact, this plot shows the contribution of each development in the NPV determined for the entire development. As seen in figure, three developments -business center, residential areas, and pedestrian areas- consist of approximately 73% of the NPV.

Finally, benefit-cost ratio (BCR) for each development is calculated and presented in Table II to estimate the monetary efficiency of each development. BCR is defined as the ratio of the benefits to relative costs of a development in monetary terms. It should be noted that the values of cost and benefit for each facility are converted to the current time. In fact, those values are the NPV of cost and benefits. As seen in the table, most of the developments have a fairly high benefit-cost ratio with the exception of UT apartments. These apartments are subsidized by UT for graduate students, which is the main reason of lower benefit-cost ratio for this development. However, the necessity of UT apartments in our development was discussed earlier.

TABLE II
BENEFIT OVER COST RATIOS OF EACH TYPE OF DEVELOPMENT

Land Type	Cost (C) (\$)	Benefit (B) (\$)	B/C ratio
Residential Area	552,326,124	1,391,102,784	2.5
UT Apartments	124,743,600	246,588,672	2.0
Educational Area	72,121,060	311,997,714	4.3
Sports Center	19,645,560	67,002,364	3.4
Health Center	75,584,448	398,689,438	5.3
Business Center	301,609,902	1,230,036,260	4.1
Commercial Area	35,913,690	190,472,626	5.3
Pedestrian Area	189,812,313	862,626,370	4.5
Theater and Museum	17,109,072	92,238,026	5.4

VI. SUSTAINABILITY IN DESIGN LEVEL

At this step, three different aspects of sustainability (urban planning, architecture, and social) will be discussed. In particular, it is investigated how these aspects of sustainability are addressed in the proposed framework.

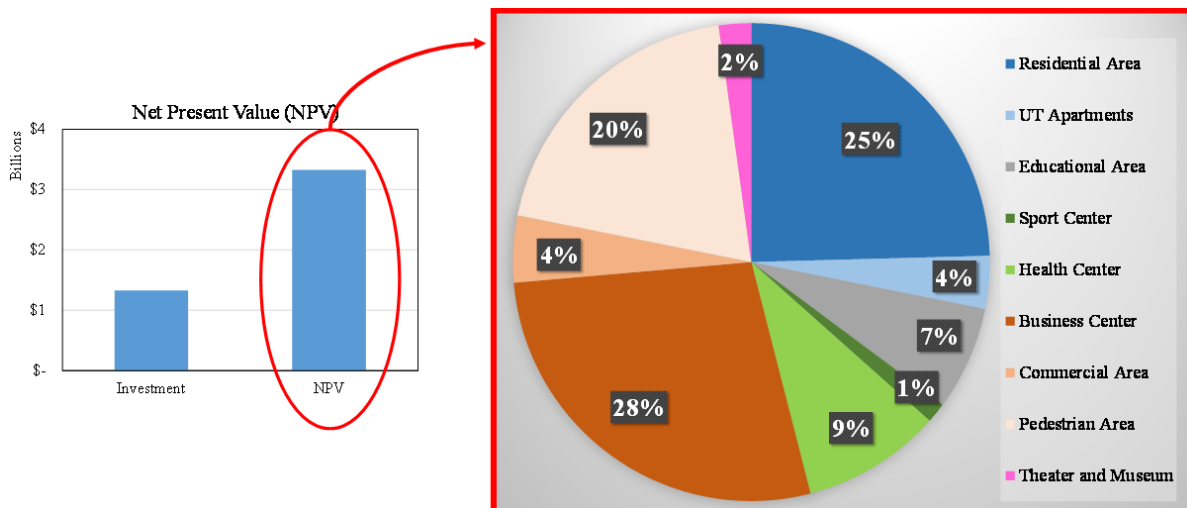

Fig. 8 Disaggregation of Net-Present Value (NPV)

A. Urban Planning

This development plan is providing an appropriate density of residents and buildings as well as suitable levels of green and open areas. Fig. 9 shows the distribution of green areas in the plan. The total amount of green areas in the site, without considering the Breckenridge Field Lab, is around 11%. Since this development has been designed according to all needs and demands, it guarantees a diverse and walkable community with easy access to educational, social and cultural areas from residential areas. To incorporate a multitude of uses, a mixed-use space is designed in the area.

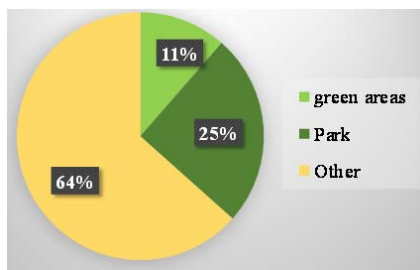

Fig. 9 Green area distribution of the proposed development

B. Architecture

To make this development plan a sustainable one from an architectural point of view, the following strategies are taken into account:

- Use environmentally friendly building materials like recycled, renewable, and ensure they require the least energy to manufacture.
- Designed to benefit from natural light to reduce the need for artificial lighting.
- Provide natural ventilation in the buildings.
- All buildings should be designed considering people with special needs.
- All buildings have to have at least silver LEEDS certification.

- Consider green roof and green wall design in the buildings where applicable.

C. Social

According to [9], “Socially sustainable communities are equitable, diverse, connected and democratic and provide a good quality of life”. To provide a good life for the residents of the area, this development plan contains a wide range of housing options for different lifestyles. Design of residential areas includes affordable housing for students, regular apartments, and big luxury apartments for families. Moreover, providing security and safety in the area is another must to reach a social sustainable society. Providing reasonable illumination in streets and public places will increase the feeling of security in whole area. Flexible utilization of lands, for example, dedicating the school’s sports field to public use after school hours, enhances the sense of belonging between residents. It is worth noting that sustainable urban development should provide the same opportunity for every resident, from young children to the elderly, both men and women, by giving services for diverse groups of people. For example, by building the library and learning centers close to residential areas, all people can easily benefit the educational services provided in those centers. Such a consideration makes an equitable society and lowers the generation gap in it.

VII. ENVIRONMENTAL ASPECTS OF DEVELOPMENT

A. Climate

Construction of residential and business areas in this development needs to consider problems associated with heat islands inside the tract. To tackle this problem, as illustrated in Fig. 10, it is suggested to use light colored and reflective materials, building shade structures at different locations of the site, keeping sufficient levels of vegetation and green area, and making permeable pavements. Minimizing trip generations is by providing all needs in the area to significantly reduce greenhouse and CO₂ gas emissions around

the tract. Moreover, a proper Waste Management Plan is suggested to apply in the design, which leads to reduced landfill waste as much as possible to minimize the landfill gas emissions.

B. Ecology

In order to protect the ecosystem and biological diversity, various kinds of plants and trees is suggested to be planted in the area. Most of these plants being local and close to nature will require the least amount of irrigation for the green areas in the tract. Moreover, since there are a large number of new residents coming to live in this area, providing education programs to introduce sustainable planting can help the area remain sustainable. Furthermore, keeping species protected and undamaged is a must in this project. The Brackenridge Field Lab, established officially in 1967 and which contains 82 acres of land, is a research station owned by the University of Texas at Austin dedicated to studies in biology. Its habitat diversity supports thousands of species from insects to plants. For instance, there are more than 400 plant species which provide the basis for an array of studies into ecology, biodiversity and ecosystems. Because of the importance of this lab, it is going to be kept in the development plan with an improvement in facilities, features, and infrastructures. The trail which is added around this area will help the public

benefit from the green nature. To benefit the educational purposes, a scientific collaboration, like providing science tours for children, is going to be made between this lab and nearby schools.



Fig. 10 Preventing heat islands

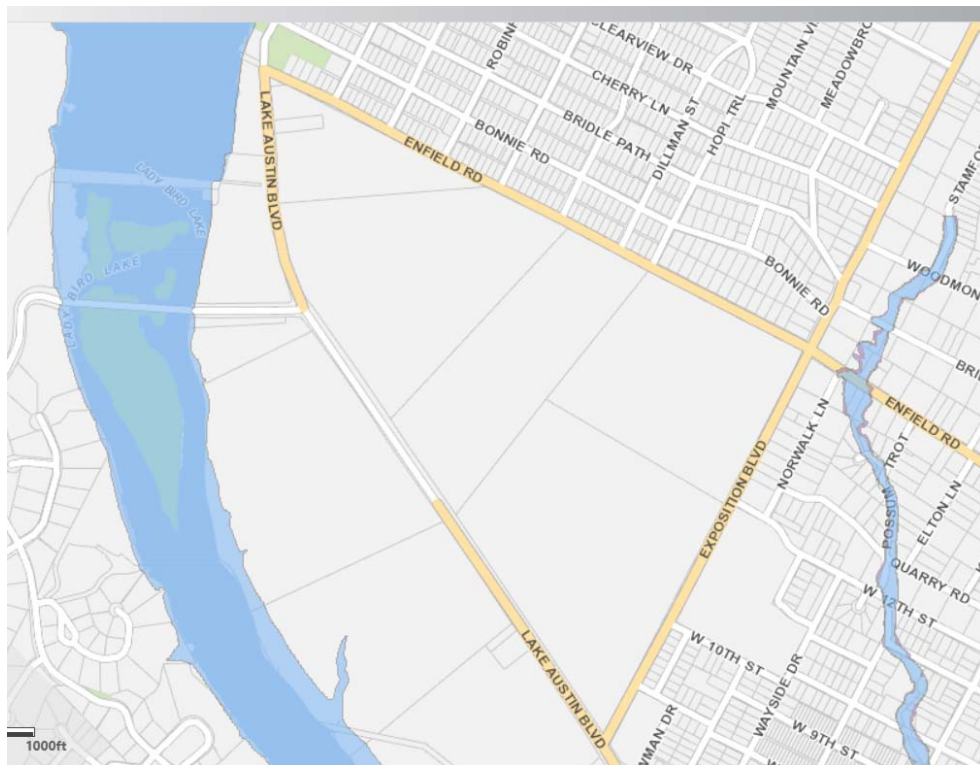

Fig. 11 Floodplain map of the Brackenridge tract; provided by City of Austin

C. Water and Soil

Water and soil resources have to be protected for natural and economic reasons. To preserve water and soil in the trace,

urban rain runoff has to be handled in a sustainable way by providing a reasonable percentage of permeable surfaces and green areas, providing rain gardens all around the area, and

using permeable asphalt mix in the streets. Moreover, to increase public knowledge and awareness about preserving water and soil, some incentives and rebates are provided for installing rain gardens and rain water harvesting tools in buildings for residents' usage. In addition, the floodplain map of Austin, as shown in Fig. 11, demonstrates that part of this trace near Colorado River is subjected to flooding and needs to be protected against it. Proper flood barriers are suggested to be used along the Colorado River to reduce the impacts of probable floods in the future.



Fig. 12 (a) Shared electric scooters and (b) shared bikes

VIII. SUSTAINABILITY IN MOBILITY

The goal of transportation design in this development is to 1) reduce automobile activity and improve safety and walkability, 2) encourage physical exercises, 3) encourage alternative transportation with zero emission, and 4) accommodate increased public transit ridership.

To reduce automobile activity and improve safety and walkability in the development, outside cars will be prevented from entering the community (i.e. the apartment area and the

pedestrian street). As shown in Fig. 13, this is achieved by locating parking garages for visiting cars only in peripheral areas of the community. There will still be roads inside the community, however, these are only prioritized to facilitate local residents' cars accessing homes, and for household waste transportation.

To provide alternative zero-emission transportation inside the development area (some distance within the development area is still too far for walking) and encourage physical exercise, shared electric scooters and bicycles, as shown in Fig. 12, will be provided. Users can scan QR codes pasted on these vehicles for around 1-hour charged usage. All roads inside the developments will feature bike lanes for safe bicycling and electric scooter ridership. Bike racks and chargers for electric scooters will be provided for every building; however, as shown in Fig. 13, those places with higher popularity will have more of these facilities. The locations of parking garages for visiting cars and places of higher bike rack and charger requirements (popular places, including the commercial area, pedestrian street, and business area) are shown in Fig. 13. In addition, because of increased population and business attractions due to the development, public transit ridership will see a significant increase. To accommodate this transformation, the Lake Austin Boulevard will be expanded to fit two bus lanes for both directions. The two existing bus stops will be upgraded, with one serving the business area, and the other serving the UT apartment area. The expanded bus lanes and upgraded bus stations are shown in Fig. 13.

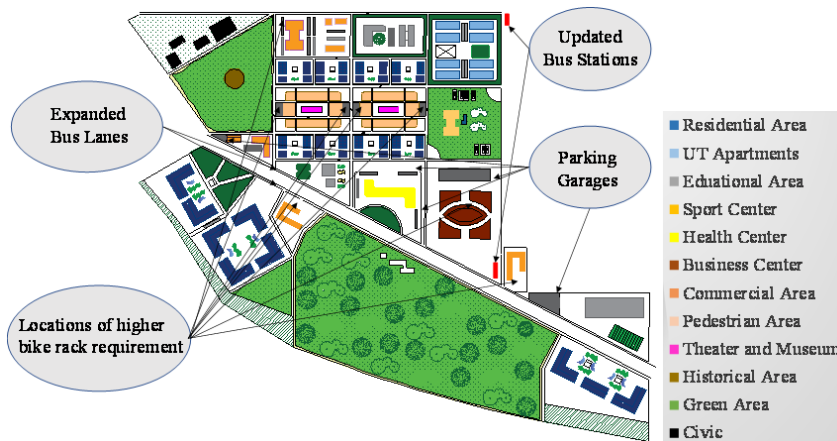

Fig. 13 Location of bike racks and parking garages as well as bus lanes and stations

IX. SYSTEM-LEVEL SUSTAINABILITY

In this section, sustainability in three different systems of the development including energy, water, and waste systems are going to be discussed in detail. In particular, it will be investigated how different strategies in each system result in a reduction in the consumption, and how more green alternatives of these systems can be used in urban development.

A. Energy System

The energy aspect of the sustainability design for this development focuses on energy saving strategies and renewable energy.

According to [10] and other data sources from the United States Department of Energy [11], [12], electricity consumptions by different building types are listed in Table III. In the same table, the total monthly electricity consumption of education buildings, healthcare buildings,

shopping malls (enclosed and strip malls), office buildings, restaurants, grocery stores, and recreation center are calculated based on the areas of these building types, while the total monthly electricity consumption of residential buildings is calculated based on the number of residents. The total monthly electricity consumption is thus estimated to be 17,848,379 kWh. Moreover, as seen in Fig. 14, according to the EIA 2009 energy consumption survey [13] because of warmer weather in Texas compared to other regions of the United States, air conditioning has a much higher contribution to the energy use of residential homes. On the other hand, the warmer weather in Texas causes space heating to account for a smaller portion of the energy use compared to other regions (i.e. 22% instead of 41%). The space heating and condition accounts for 40% of Texas household energy use, while appliances, electronics, and lighting accounts for another 41%. Since it is not so easy to control appliances and electronics consumption at the early stage of design, the energy saving strategy will be focused on HVAC (including space heating and air conditioning) and lighting.

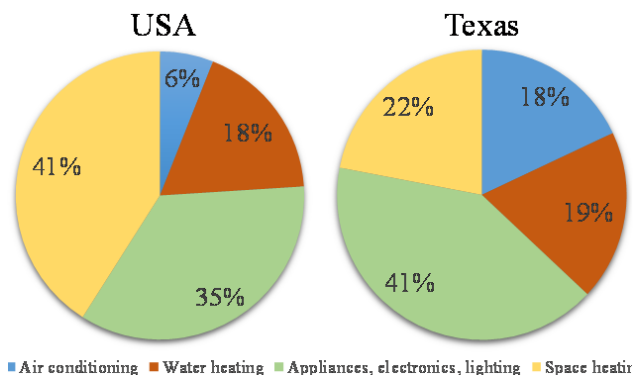

Fig. 14 Building Energy Consumption Breakdown [10]

TABLE III
ELECTRICITY CONSUMPTION ESTIMATE

Residential Buildings			
Total Monthly Electricity Consumption	Total # Residents	Individual Electricity Consumption	Electricity Consumption
kWh/Mon		kWh/Mon	kWh/Mon
17848378.8	4278	1000	4278000
Commercial Buildings			
Building Type	Avg. Electricity Consumption kWh/sq.ft/Mon	Building Area Sq.ft	Electricity Consumption by Building Type kWh/Mon
Education	11	171465	1886115
Health Care	25.8	77190	1991502
Enclosed and Strip Malls	21.1	23813	502454.3
Office	15.9	266385	4235521.5
Restaurant	29	32529	943341
Grocery Store	52.5	62258	3268545
Recreation Center	38	19550	742900

The HVAC system is crucial for building's heating, cooling, ventilation, and humidity control. Typically, the air handling units (AHU) of HVAC systems exchanges room air

with fresh outdoor air to meet the ventilation requirement (thus a certain amount of room air will be exhausted in exchange of fresh air), while heating or cooling the supply air according to indoor temperature requirement, based on building heating and cooling loads. During this process, a considerable amount of energy is lost with the exhaust air. Therefore, heat exchangers can be very helpful for saving energy, as they use exhaust air to pre-heat or pre-cool the fresh air, reducing the energy needed by the heating and cooling coil. For this development, high efficiency air handling units (AHU) with heat recovery features will be introduced. For smaller buildings (restaurants, grocery stores), high efficiency AHUs with cross-flow heat exchangers will be installed. For medium to large buildings (apartments, health center, recreation center, schools), high efficiency AHUs with heat recovery wheels will be introduced. Cross-flow heat exchangers are compact and therefore suitable for small buildings. Heat recovery wheels are more efficient because they not only recover sensible heat, but also recover latent heat. However, heat recovery wheels are large and more expensive to maintain and thus, more suitable for larger buildings with a greater amount of heating/cooling load. According to the Department of Energy, those high efficiency AHUs are capable of saving 30% ~ 50% of HVAC energy due to their heat recovery abilities.

For the business center, however, a more efficient system is required, because the five buildings in the business center are large high-rise office buildings, leading to much greater amount of HVAC energy consumption. It will be a 2000-ton centralized chilling system with a cooling tower, as shown in Fig. 15, which uses water to cool the condenser and supply air in the AHU. Because water has much higher heat capacity than air, the chilling system has a considerably higher coefficient of performance (COP = heating or cooling energy / energy input), thus becoming more energy efficient than a normal air-cooled HVAC system. Because chilling systems are expensive to maintain, instead of installing a separate system for each building, the five buildings in the business center will share a large centralized chilling system to control the maintenance cost. Also, because all of the five buildings are office buildings, they will have similar operation schedules, thus having less zoning problems (when different buildings have different heating/cooling/ventilation loads) for the centralized chilling system.

In addition to the HVAC system, buildings in this development will have passive architectural design. With passive designs, buildings can reduce ventilation loads by taking advantage of natural ventilation, and reduce lighting consumption by having appropriate daylighting design. Passive designs can be achieved by appropriate building orientation, shaping, and façade. Also, Energy Star rated LED lights will be introduced to all buildings. According to the Department of Energy, LED lights produce 55~70 Lumens per Watt, which use 75% less energy than regular incandescent lights (13~18 Lumens per Watt), and last 25 times longer [14]. Moreover, for renewable energy, solar PV panels are chosen because 1) Austin has a decent monthly global horizontal solar

irradiance, and 2) solar panels are simple, have minimal moving parts, and are cheap to maintain. As shown in Table IV, according to Solar Energy Local, when tilted at the latitude of Austin, solar installations in the city can produce 5.21 kWh/m²/day (14.53 kWh/sq. ft/Month) of electricity. In this development, the rooftop areas of the apartments, school buildings, shops and some of the office buildings in the business center will be utilized to install solar panels [15]. As shown below, with the total available rooftop area estimated as 348,880 sq. ft, the total solar installation can potentially cover over 28% of the electricity consumption of the entire development.

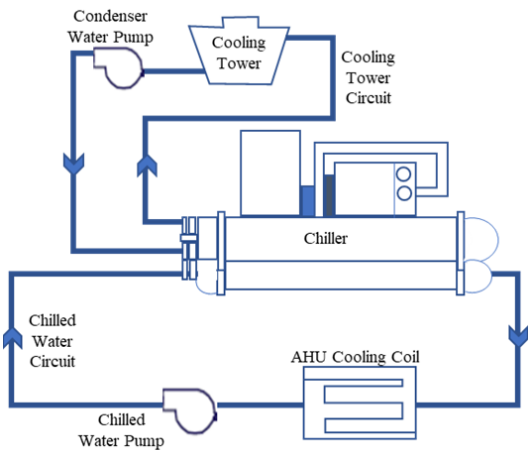

Fig. 15 Chilling system

TABLE IV
SOLAR PANEL GENERATION

Available roof top area	Monthly PV generation per unit area	Monthly total PV generation	Generation-consumption ratio
(sq. ft)	(kWh/sq. ft/Month)	(kWh/Month)	
348,880	14.53	5,067,839	0.284

B. Water System

The water aspect of the sustainability design for this development focuses on water saving strategies, which includes household water saving, water recycle, and rain water harvesting.

According to [10], [18], and other data sources, water consumption by different building types are listed in Table V [16], [17]. In the same table, the total daily water consumption of the education buildings, healthcare buildings, shopping malls (enclosed and strip malls), office buildings, restaurants, grocery stores, and recreation center are calculated based on areas of these building types, while the total daily water consumption of the residential buildings is calculated based on the number of residents. The total daily water consumption is thus estimated to be 277,245 gallons. This amount of water will be supplied by City of Austin Water Utility, from the treatment plants that pump surface water from the Colorado River, according to Austin Water [18].

From the water consumption estimate (shown in Table V),

residential water accounts for 80% of all water consumption for the entire development, and therefore, the water saving strategy will be focused on saving residential water. To a large extent, residential water use can be minimized through modifying the behavior of residents while using water, however, this is not within the scope of this development. Therefore, water saving showerheads, water saving toilets, and high efficiency washing machines will be recommended for the residential apartments.

TABLE V
WATER CONSUMPTION ESTIMATE

Total Daily Water Consumption	Residential Buildings		
	Total # Residents	Individual Indoor Water Consumption	Total Residential water Consumption
Gal/Day		Gal/cap/Day	Gal/Day
277245.427	4278	52.1	222883.8
Commercial Buildings			
Building Type	Avg. Water Consumption	Building Area	Water Consumption by Building Type
	Gal/ksf/Day	Sq. ft	Gal/Day
Education	40	171465	6858.6
Health Care	159	77190	12273.21
Enclosed and Strip Malls	32	23813	762.016
Office	40	266385	10655.4
Restaurant	589	32529	19159.581
Grocery Store	65	62258	4046.77
Recreation Center	31	19550	606.05

According to [18], water saving toilets control water flow by 1) dual flush feature that saves 15,000 gallons of water each year, and 2) ultra-low volume feature that use less than 1.6 gallons per flush. Water saving showerheads with low-flow faucet aerators can restrict shower water to less than 2.5 gallons per minute. High efficiency washing machine use as little as 7 gallons of water per load, compared to 54 gallons for conventional washers, and new Energy Star rated washers use 35% ~ 50% less water and 50% less energy per load. These household water saving features combined, as shown in Table VI, can save 44% (30.1 gal/68.3 gal) of residential water use, which is equivalent to 98,068 gallons per day in this development. In addition, rain water and grey water from household sinks, bathtubs, and laundry machines will be harvested by a grey water system, which reroutes water from drains to landscaping or water collection tanks. The harvested and recycled water will be used to irrigate the green areas, and more importantly, as cooling water in the cooling tower and chillers of the chilling system, as described in the previous section, and shown in Fig 15. Energy saving and water saving strategies come together as an integrated design.

C. Waste Management System

Waste sorting trash bins will be provided to all public areas (schools, commercial buildings, offices, recreational centers, pedestrian streets), with pictures of trash, cans & bottles, and papers labeled to make sure users know where to dispose of their waste.

TABLE VI
HOUSEHOLD WATER SAVING ESTIMATE [20]

	Frequency of Use (per person)	Daily Water Use Without Water Conservation Device (gal/person)	Daily Water Use with Water Saving Device (gal/person)	Daily Water Saving with Water Saving Device (gal/person)	Annual Water Savings (gal/person)	Estimated Annual Energy Saving of kilowatt-hours (per person)
Low-flush toilet (1.6 gpf)	5.1 flushes/day	20.4	8.2	12.2	4,453	0
Low-volume Showerhead (2.5 gpm)	5.3 minutes/day	15.9	13.3	2.6	949	123
Low-volume Faucet (rated flow 1.5 gpm)	4 minutes/day	12	6	6	21,090	125
Front-loading Washing Machine (27/gpl)	0.37 loads/day	18.9	10	8.9	3,249	316
Water-Efficient Dishwasher (7.0 gpl)	0.1 loads/day	1.1	0.7	0.4	146	36
Total		68.3	38.2	30.1	10,987	600

As shown in Table VII, according to [19], residential waste production in Austin is around 6.5 lb/people/day. With a total number of 4278 residences in the development, the daily residential waste production is estimated at 13.9 tons/day. This waste will be transported to Austin Community Landfill located at Highway 290 East Giles Road, and contribute to a gas-to-energy power plant that reclaims electricity from landfill gas. The gas-to-energy power plant, which collects 3500 tons of waste from all over the Travis County every day, is producing electricity capable of powering 4000 to 6000 homes.

TABLE VII
WASTE PRODUCTION

Daily waste/Resident (lb/cap/day)	Residence	Daily waste (tons/day)
6.5	4278	13.9

X. CONCLUSION

This paper puts forward a multi-objective framework for sustainable urban development. The proposed framework considers different aspects of sustainability in urban development planning, while ensuring that it locally meets the needs of present and future generations with respect to economic, social, environmental, health as well as cultural aspects. Then, the proposed framework is implemented in developing a sustainable area in Brackenridge Tract located in downtown Austin. The area for development is approximately 350 acres. The development considers sustainability in different aspects from planning, design, architecture to system-level facilities such as mobility, energy, water, and waste systems.

ACKNOWLEDGMENT

The authors gratefully thank to Dr. Fernanda Leite, Mr. Alvaro Zilveti and Mr. Haitian Liu from The University of Texas at Austin for fruitful discussions.

REFERENCES

- [1] S. N. Kondepudi, "Smart Sustainable Cities: An Analysis of Definitions," *ITU-T Focus Group for Smart Sustainable Cities*. 2014.
- [2] M. Cetin, "Using GIS analysis to assess urban green space in terms of accessibility: case study in Kutahya," *International Journal of Sustainable Development & World Ecology*, vol. 22, no. 5, pp. 420–424, 2015.
- [3] G. Sanesi, G. Colangelo, R. Laforteza, E. Calvo, and C. Davies, "Urban green infrastructure and urban forests: A case study of the Metropolitan Area of Milan," *Landscape Research*, vol. 42, no. 2, pp. 164–175, 2017.
- [4] N. Kabisch, "Ecosystem service implementation and governance challenges in urban green space planning: The case of Berlin, Germany," *Land use policy*, vol. 42, pp. 557–567, 2015.
- [5] Y. Voytenko, K. McCormick, J. Evans, and G. Schliwa, "Urban living labs for sustainability and low carbon cities in Europe: Towards a research agenda," *Journal of Cleaner Production*, vol. 123, pp. 45–54, 2016.
- [6] P. Nijkamp and A. Perrels, *Sustainable cities in Europe*. Routledge, 2018.
- [7] "U.S. Census Bureau QuickFacts: New York County (Manhattan Borough), New York; UNITED STATES." .
- [8] "Guadalupe-Lamar is highest-density corridor in Austin — according to Austin Rail Now." .
- [9] L. Barron and E. Gauntlet, "WACOSS housing and sustainable communities' indicators project," in *Sustaining our Communities International Local Agenda 21 conference, Adelaide*, 2002.
- [10] EIA, "2012 Commercial Buildings Energy Consumption Survey: Energy Usage Summary," 2012.
- [11] EnergyStar, "Schools: An Overview of Energy Use and Energy Efficiency Opportunities," *Energy*, 2006.
- [12] U. S. Energy Information Administration, "International energy data and analysis, Korea," *U.S. Energy Information Administration*, 2015.
- [13] EIA, "Residential Energy Consumption Survey (RECS)," 2009, 2009. .
- [14] U.S. Department of Energy, "Buildings energy databook," *Energy Efficiency & Renewable Energy Department*, 2011.
- [15] "Solar Energy & Solar Power in Austin, TX | Solar Energy Local." .
- [16] W. B. Deoreo, P. W. Mayer, B. Dziegielewski, and J. C. Kiefer, *Residential End Uses of Water, Version 2*. 2016.
- [17] H. W. (Bill and) Hoffman, "Analysis of Five Years of Municipal Water Use Data To Estimate Commercial and Institutional Per Capita Use," 2016.
- [18] "Water Conservation: 45 ways to conserve water," *Eartheasy Guides & Articles*. .
- [19] City of Austin open data portal, "2015 Annual Performance Report Key Indicators," 2015.
- [20] A. Vickers and R. A. Cohen, "Handbook of water use and conservation," *Electronic Green Journal*. 2002.