

Design and Simulation of Heartbeat Measurement System Using Arduino Microcontroller in Proteus

Muhibul H. Bhuyan, Mafujul Hasan

Abstract—If a person can monitor his/her heart rate regularly then he/she can detect heart disease early and thus he/she can enjoy longer life span. Therefore, this disease should be taken seriously. Hence, many health care devices and monitoring systems are being designed to keep track of the heart disease. This work reports a design and simulation processes of an Arduino microcontroller based heart rate measurement and monitoring system in Proteus environment. Clipping sensors were utilized to sense the heart rate of an individual from the finger tips. It is a digital device and uses mainly infrared (IR) transmitter (mainly IR LED) and receiver (mainly IR photo-transistor or IR photo-detector). When the heart pumps the blood and circulates it among the blood vessels of the body, the changed blood pressure is detected by the transmitter and then reflected back to the receiver accordingly. The reflected signals are then processed inside the microcontroller through a software written assembly language and appropriate heart rate (HR) is determined by it in beats per minute (bpm) from the detected signal for a duration of 10 seconds and display the same in bpm on the LCD screen in digital format. The designed system was simulated on several persons with varying ages, for example, infants, adult persons and active athletes. Simulation results were found very satisfactory.

Keywords—Heart rate measurement, design, simulation, Proteus, Arduino Uno microcontroller.

I. INTRODUCTION

ENGINEERING and technology has enabled our life-style Every comfortable today. In each professional field, application of knowledge of engineering and technology in medical science has made the tasks of medical professionals very easy. Out of the several medical data, the HR and body temperature are the most common. From these data, the medical professionals diagnose the problems related to cardiovascular diseases. Without the help of this machine, the doctors and health professionals are unable to detect the heart related problems of human body. However, this detection is very necessary, since the world possesses about an aggregate of 17.65 million individuals who are at a high risk of getting attacked by the Cardiovascular Diseases (CVDs) [1]. CVDs are a group of ailments of the heart and blood vessels, such as, coronary heart disease, cerebrovascular disease, rheumatic heart disease etc. This group of diseases has become the number one reason for loss of life worldwide. Heart disease is

not only the main cause of premature death in most of the countries in the world but also it is the cause of early disability of people. It has been reported that among these deaths, 37% were due to CVDs [1].

HR is one of the key factors that should be monitored to get proper information about the cardiovascular system of our body. The value of HR varies between 72 and 120 bpm (beats per minute) for a healthy adult person [2] at rest and an athlete respectively. Usually, an inactive person has lower HR than that of an active person. On the other hand, an infant may have higher value of HR, while grown up children may have HR value at about 90 bpm. The value of HR rises progressively through works and exercises [3] and comes back to its rest value gradually after the work or exercise is over. The rate, at which the values return to the standard magnitude, gives us a hint about our health status. If the HR value is less than its standard/nominal value then this condition of heart is known as bradycardia, and if it is greater than its standard value then it is called tachycardia. If we can detect the HR of patient at his/her early stage of heart disease then we can reduce the death casualties and save the lives of many people on this earth.

In today's biomedical engineering field, there are so many types of machines and equipment as well as methods and techniques to diagnose heart related diseases, for example, electrocardiogram (ECG), echocardiogram using ultrasound, cardiac magnetic resonance imaging (MRI), cardiac computed tomography (CT) scan, positron emission tomography (PET) scan, angiogram etc. Amongst these, HR measurement is the most common diagnosis method, and it can be applied in wide areas. Cardiologists or doctors can detect the heart's problems or functionality directly from this machine. Therefore, its efficient determination is necessary to detect and thus to provide necessary treatments to the different kinds of patients having heart diseases.

In light of the above contexts, enormous endeavors have been applied to facilitate the best healthcare services at an affordable expense during the last few decades. With the rapid advancements in engineering and technological fields, it has become feasible to design and develop more efficient, reliable and affordable biomedical machines and equipment with new additional but important features. This has also made these biomedical machines more user-friendly. CVD related signs and symptoms can now be obtained in smart mobile phones or similar devices which are portable and wearable [4]. The prime objective of this work is to design an automated and low cost heart beat measurement system to help and support the doctors to monitor their patients' conditions. However, this

M. H. Bhuyan is with the Department of Electrical and Electronic Engineering (EEE), Southeast University, 251/1 & 252 Tejgaon Industrial cum Commercial Area, Dhaka, Bangladesh. Email: muhibulhb@gmail.com (corresponding author, phone: 88-01815-657346; e-mail: muhibulhb@seu.edu.bd).

M. Hasan is with the Department of EEE, Southeast University, 251/1 & 252 Tejgaon Industrial cum Commercial Area, Dhaka, Bangladesh (e-mail: 2015000500073@seu.edu.bd).

machine is not still so cheap to the people of the under-developed or developing countries. Moreover, doctors and medical staff are not physically available to all required places throughout the country. Therefore, it would be supportive if it is possible to design and then implement a system for the people of these countries to observe their heart conditions at an affordable cost from remote places. The biomedical engineers are trying to find a way to address these problems and a suitable solution for it. This will certainly decrease their on-site visiting time. Moreover, the Arduino microcontroller is very cheap and readily available in the market and requires fewer efforts for its programming to automate the system. Also these are used in various biomedical and other similar applications due to its compactness, portability, less power consumption, enhanced battery life, high operating speed etc. [5]-[8]. This Arduino microcontroller with analog interfacing circuits, sensors, electrodes, amplifier, sampler and filter can acquire the very weak signal from the chest and send it to the microcontroller's output port in appropriate format. Then a set of programing instructions inside the microcontroller can determine the HR of the patients being monitored. Therefore, our objectives of this work are to-

- i. Design a low-cost HR monitoring scheme that can measure heart beat
- ii. Use the microcontroller for signal processing and other computation to make it faster responding
- iii. Simulate the system for various aged persons
- iv. Analyze HR signals

II. LITERATURE REVIEW

In the literature, HR measuring devices were found to be designed and developed by many researchers around the world for several purposes. In the preliminary research papers, the HR or pulse rate was obtained for clinical studies. For this purpose, the electrical signal was analyzed in the pulse format that can be utilized for important medical studies. One such research prototype was developed based on hardware and software components to detect the pulse rate and then analyze the designed system. The hardware portion used the Atmega2560 ADK R3 microcontroller as the main part to process the input signals obtained from the optical sensors in the form of pulses and finally to send the results to the LCD screen for display purpose and to the SD memory card for data storage purpose. The software part of this system provided an embedded algorithm in the form of an assembly language program to control the overall processing and input/output operations. Since optical sensor data are analog in nature so an analog to digital converter (ADC) circuit has also been used before sending the signals to the microcontroller. They took the data from the 40 subjects after taking the concept due to ethical issues of the research. They explained their results through experiments on their subjects' responses through investigating the maximum or minimum pulse rate values and its patterns. The main characteristic of their prototype is that the developed system is accurate, durable, low power consuming, and low cost [9].

In another article, a HR monitoring system was developed

using a novel step counter algorithm when physical activities are going on. This type of algorithm enables to detect the HR with high accuracy at each step of detection. In this paper, the authors proposed to use a wireless wearable device, a smartphone and a remote server as the main hardware components of the system. Bluetooth low energy is used to transmit the data between the wearable device and smartphone. They have used contactless method to get the HR data and eliminated the use of direct contact electrodes to avoid any kind of aches or pains or scratches of skin. They claimed that their proposed system is compact, lightweight and comfortable for the user. To display the measured data, they used smart phones. However, since smart phone cannot communicate directly with the hardware system, application software has also been developed to provide the proper interface to the HR counting system. This can also measure the other health parameters like, step count (SC), exercise intensity, speed, distance, and calories burned as well as waveforms related to the ECG and step cycle. The designed system could measure the HR at an accuracy level of 98.89% [10].

Another paper presented a prototype system to monitor the heart beat rate. In this system, a Heart Beat (HB) sensor was designed using Light Dependent Resistor (LDR) and Light Emitting Diode (LED). The LED sends the optical signal to a person and the reflected wave is sensed by the LDR which can convert the light energy into the electrical energy according to the HB pulse rate of that person and converts it in the form of electrical pulses. But the amplitude of these pulses is too weak to process further. That is why, the signals are amplified using an amplifier circuit and then digitized for sending to the microcontroller which then processes the signal and calculate the HR based on its assembly language program. If the user puts his/her finger in the HB sensor the necessary input signals are collected by the sensor. The authors also claimed that the proposed system is simple and effective as well as uses a robust method. They have simulated the system in Proteus and also implemented on the hardware to demonstrate its efficacy [11].

Digital Signal Processing (DSP) techniques are being used in many applications of power electronics system [12]. Now this technique has been applied in detecting the important information of ECG signals by observing it in the monitor with the aim of assisting the physicians or cardiologists [13]. DSP algorithms with Fourier and Wavelet spectra are used for ECG diagnostics of the CVD patients [13]. This would assist the cardiologists or physicians for accurate analysis and diagnosis of the disease and its magnitude. Besides, the DSP hardware based system has been designed and implemented using the digital signal processor with memory, signal display system and analog interfacing circuit [14], [15]. This type of system with DSP has the ability to operate as stand-alone and to update the data in real-time according to the on board pre-program algorithm for ECG analysis [16].

A home-made pulse diagnosis device was built to measure human pulses in another research paper found in literature survey. This system is manufactured utilizing a piezoelectric

transducer, differential amplifier and a data acquisition instrument. Besides, a MATLAB program has been developed to analyze the system's performances. At first, the pulses were measured and converted into the appropriate electronic signals by use of a piezoelectric transducer and the data were saved on a computer in digital format. After that these were processed and analyzed using Fast Fourier Transform (FFT) method. The regular and irregular pulses were segregated by observing the phase shifts, but not by the frequency spectrum [17].

In another paper, a wireless belt was used to measure the HR pulse continuously. According to their system, it can also measure the temperature. Both of these parameters can be obtained from human body and after proper processing of these signals an appropriate SMS can be sent to the medical professionals and the patient's family members at the time of heart attack, and thus treatment can be provided in time or the patient can be moved to the hospital at the right time. For this system, a Wi-Fi enabled microcontroller has been used [18].

In another study, the authors reported a portable and low cost HB rate measurement device designed using PIC 16F877 microcontroller. It can measure the HB rate based on the optical data obtained from the fingertip of a person; this rate is then displayed on an LCD screen. But the working voltage for this device is a 9V DC battery. The additional features of this system are that it can also measure the temperature and humidity of the surroundings [19].

In another research article, a method for determining the HR of a human using a video sequence has been presented. The method is contact-free and needs very cheap biomedical apparatus. The video sequence can be taken with a USB

camera connected to a personal computer. The results also reveal that the forehead and cheeks are more suitable for the measurement purpose [20].

In another research paper, the authors proclaimed that they have investigated that the impulse-radio ultra-wideband (IR-UWB) radar could recognize the cardiac motions without having any physical contact with the patients. Hence they devised a method for the measurement of HR and rhythms using an IR-UWB radar type sensor. Then they have estimated the validity and reliability of the measured HR data and compared it with the HR data obtained from the electrocardiography (ECG) measurements. The comparative study revealed the precision and accuracy of the IR-UWB radar sensor based contactless HR data [21].

III. SYSTEM DESCRIPTION

A. Block Diagram of the System

The system contains an Arduino microcontroller, HB sensor, a Liquid Crystal Display (LCD) unit and a DC power supply unit. We would like to design the circuit in Proteus. However, the HB sensor unit has a filter circuit, noise eliminator circuit and also an amplifier circuit. The power supply unit supplies the required current to the microcontroller and HB sensor circuits directly at 5V but the LCD display unit, having two lines each containing 16 characters, gets its power from the Arduino Uno R3 microcontroller. The chunk illustration of the entire system connecting the major units of our designed machine is made visible in Fig. 1.

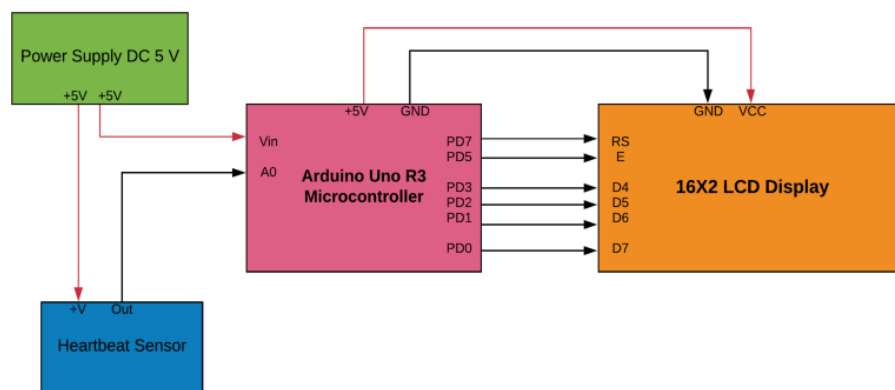

Fig. 1 Block diagram of the HR measurement machine

At first, HR pulse sensor unit senses the HR signal of the human body from their fingertips which is placed in between the two sensors, viz. an optical transmitter and an optical detector. This signal may contain noises and that is why it is sent to the RC passive filter circuit to eliminate the noise signal from the HR signals.

The IC, LM358- a dual operational amplifier integrated with two op-amps powered by a common power supply of 5V (though this IC can be operated with an extensive choice of single power supply from 3V to 32V and of dual power supply

extending from $\pm 1.5V$ to $\pm 16V$), is used to eliminate the noise and to amplify the analog signal as well as to improve the transfer conductance of the circuit. Then the signal is sent to the common emitter based transistor amplifier circuit.

The amplifier circuit uses a BC547 transistor- an npn type transistor having high gain of above 400 over a varied range of collector current and can provide the collector current over 10 mA when operated at +5V DC power supply. The common emitter configured bipolar junction transistor (BJT) uses a few resistors and capacitors to design the amplifier circuit [23].

This reduces the design cost of the system without compromising the accuracy level of measurements. Without the analog signal's amplification, we cannot convert it to the digital signal and hence get the accurate HR data properly. The transistor based amplifier circuit enhances the current level of the unit and sends the amplified signal to the microcontroller unit.

Arduino Uno R3 microcontroller is used to process the

signal based on its program, it calculates the HR in bpm and sends it to the LCD display unit to display the measured value in appropriate format as programmed in the microcontroller.

The DC power supply unit supplies the required DC power to the sensor, amplifier, microcontroller unit and display unit at +5V DC. Since the HR pulse sensor unit, HPS162 is not available in Proteus, so an equivalent hardware circuit is designed and represented in Fig. 2.

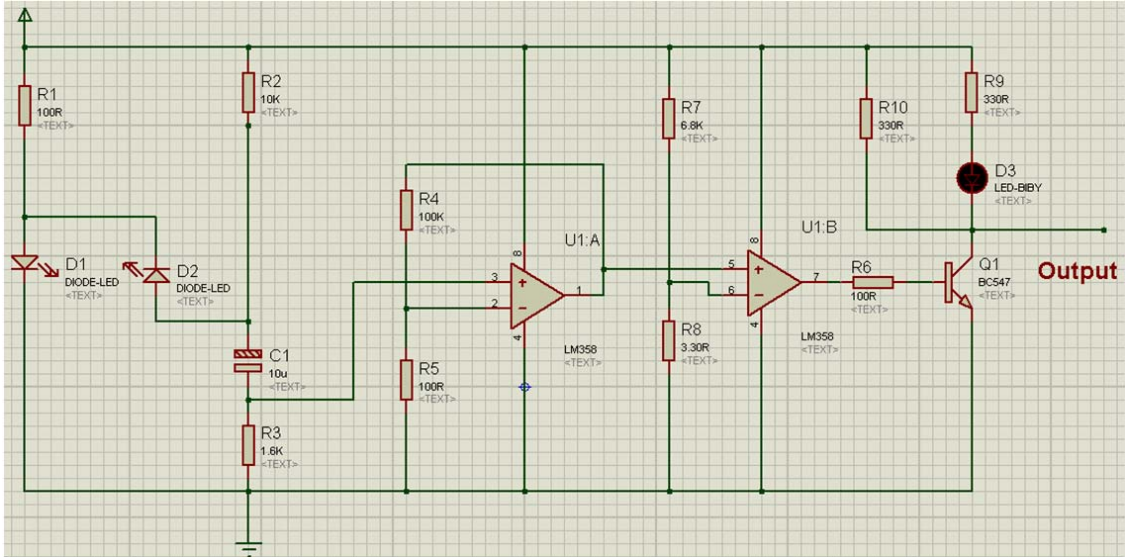

Fig. 2 The amplifier circuit unit

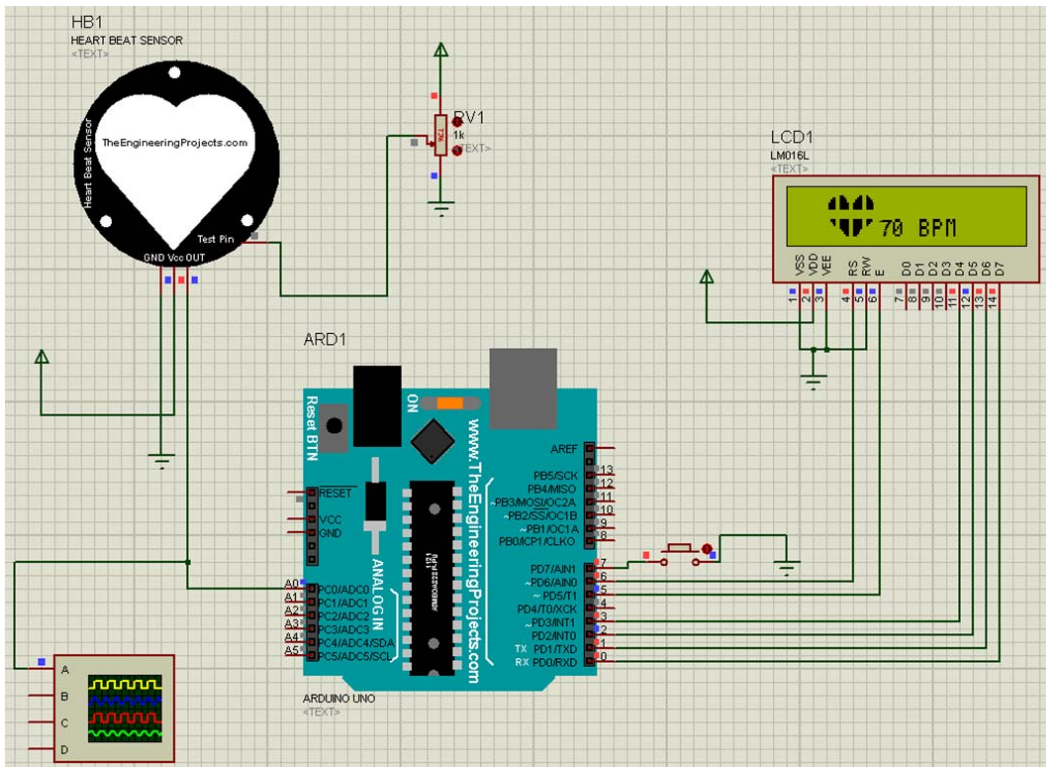

Fig. 3 Complete circuit diagram of the designed HR measurement system in Proteus

The HB sensor is basically a set of transducers that are placed at some small distance apart. Within this sensor's gap human finger has to be placed to collect the electrical activity of the heart of his/her body. Since nerve and muscles are electrically active, and the heart can generate electrical current and voltage signals of very low amplitude these are sensed by the sensor (HPS16), but cannot be detected by the microcontroller. Of course, this is an analog signal as well. Therefore, it is required to be amplified by the amplifier and sampled by the sampler to convert the analog signal to Pulse Amplitude Modulated (PAM) signals of sufficient amplitude. Then a filter circuit is also used to remove any noise stemming from any part of this analog interfacing circuit or signal collecting electrodes. After getting this PAM signals, the microcontroller converts it into the appropriate digital signal through its processing algorithm and produce the ECG wave form according to the developed software and send the signal to the display system connected to it through its output port.

Each unit is then analyzed and designed properly. After the selection of components for each block and calculation of the values for the required components, the circuit is drawn in Proteus. With the application of the appropriate signals, it is then simulated and finally the display unit provides the HR in bpm with a heart symbol to the left of the HR data as presented in Fig. 3.

Arduino Uno R3 microcontroller is used in this work due to its several features, such as, low power consumption, high efficiency, in-built ADC and communication in USART mode. In-built ADC is used to convert the PAM signal into digital format. Serial data transmission feature is utilized to transmit and receive the ECG data to the and from the outside of the microcontroller respectively. To transmit the data in serial communication mode, we selected the baud rate of 9600 bps and sampling rate of 320 samples/s. Arduino Uno's pin numbers 1 and 0 are connected to the Bluetooth module's Rx and Tx terminals for transmission and reception of signals respectively [22].

A DC power supply voltage of 5 V has been designed using the voltage regulator IC LM7805. A center-tap transformer along with diodes are used to step down the power line AC voltage of 220V with 50 Hz frequency and then to rectify the signal. To smoothen the pulsed rectified signal and to eliminate any DC offset signals two more capacitors having capacitance values with 1 μ F and 470 μ F are used at the input and output terminals of both the regulator ICs respectively. The use of capacitors also help to eliminate any power line frequency related and other noise interferences to the microcontroller [23].

The final design is to be implemented in a Printed Circuit Board (PCB). For this purpose, PCB design is also done in Proteus and is shown in Fig. 4 with placement of various components used in the circuit.

To obtain the HR of human body, a person needs to place his/her fingertip in between the two sensors. An IR sensor sends the light signal that passes through the blood flowing inside the veins of the fingertip and its variation is detected by the IR photo detector diode. After filtering, amplifying and

sampling of the analog signal to the appropriate digital signal, it is sent to the microcontroller unit.

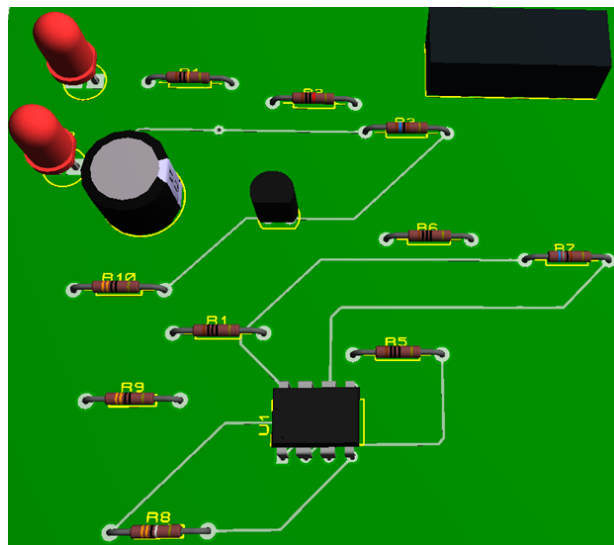

Fig. 4 PCB design of the complete circuit with component placements in Proteus

B. Software Program Design

Since this system uses microcontroller, we need to develop software program as per logic required for the program. Arduino microcontroller uses assembly language program. At first, we need to identify what function this program should perform. We need two types of programming- one is at the layer of the device and the other is at the layer of the application. At the device layer, we need a program that would be capable of driving hardware of the system. However, at the application layer, the program must be able to calculate the HR and then display its value and unit in appropriate format at the designated display device. For microcontroller programming, an integrated development platform is used. The flow chart of the developed program is shown in Fig. 5. This program reads the HB sensor output in digital format at the inputs of the microcontroller by scanning its serial port. Then this digital data signal is transferred to the microcontroller's memory, process it inside the microcontroller as per instruction sets of the assembly program, convert it into the appropriate format in bpm and finally send to the output port for displaying the data in a suitable text format in bpm in the LCD screen.

To display the HR signal at the designated display unit (here it is LCD screen), software has been developed. The tasks of this software are to process the data to display it in appropriate format in bpm. The output ports are properly initialized to send the data to the LCD screen's input connected to the output port. Whenever the output port gets the available data at any instant of time, the LCD screen displays the heart rate value in bpm with a heart symbol.

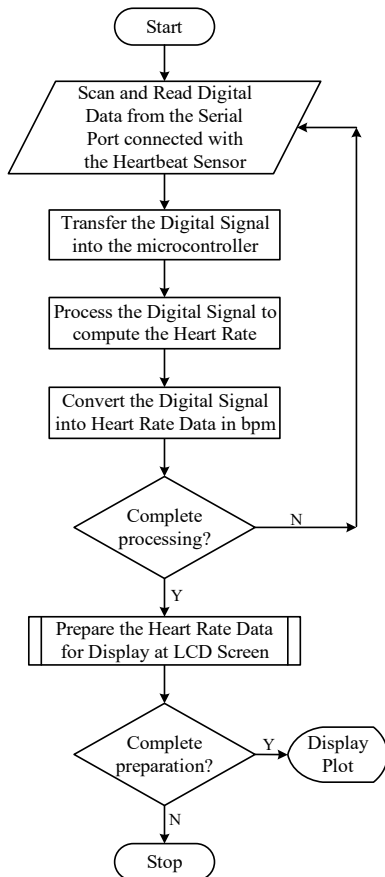

Fig. 5 Flow chart of the microcontroller program of the designed HR measurement system

IV. RESULTS AND DISCUSSIONS

To measure the heartbeat rate, a Proteus simulation is developed. The Proteus simulator is used to obtain the HR of different ages of human beings, like infant, adult, athlete etc. Using this process, the proposed heartbeat rate is easily measured. Fig. 6 shows the heartbeat signal’s digital waveform having two levels of 5 V and 0 V. This signal is obtained after processing the sensor’s analog signal in Proteus.

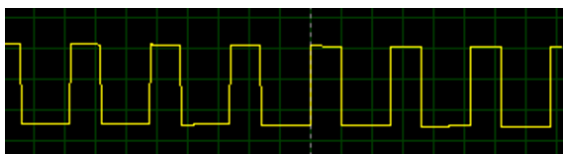

Fig. 6 Heartbeat sensor signal from the circuit in Proteus

In this research, we analyze the performance of the proposed HRM model based on five case studies as follows:

- i. To measure the heartbeat of infant
- ii. To measure the heartbeat of older children
- iii. To measure the heartbeat of teenage
- iv. To measure the heartbeat of adult
- v. To measure the heartbeat of active athlete

The heart signal’s amplitude varies with respect to time,

which is represented in a waveform. From the waveform of heart signal (amplitude vs. time), the HR in bpm can be calculated by (1):

$$HR = \frac{1}{\text{Time to complete one cycle in sec}} \times 60 \quad (1)$$

Fig. 7 represents the heartbeat rate of an infant. It shows that the amplitude of the voltage signal is 1.67 V and time to complete one cycle is 414 ms. Thus the HR is 145 bpm, Fig. 8 represents the heartbeat rate of a child. It shows that the amplitude of the voltage signal is 0.65 V and time to complete one cycle is 529 ms. So, the HR is 113 bpm, Fig. 9 represents the heartbeat rate of a teenage child. It shows that the amplitude is 1.01V and time to complete one cycle is 828 ms. Therefore, the HR is 72 bpm, Fig. 10 represents the heartbeat rate of an adult. It shows that the amplitude is 3.45V and time to complete one cycle is 989 ms. Therefore, the HR is 61 bpm,

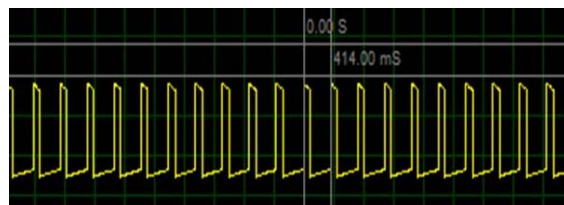

Fig. 7 HR for an infant

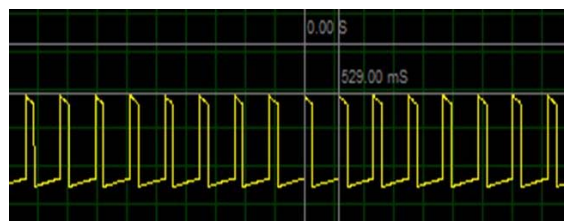

Fig. 8 HR for a child

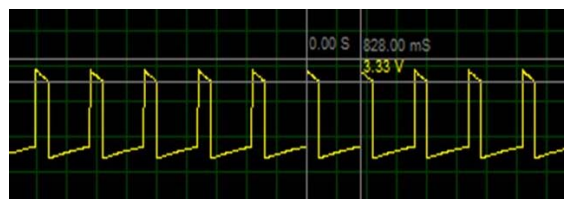

Fig. 9 HR for a teenaged

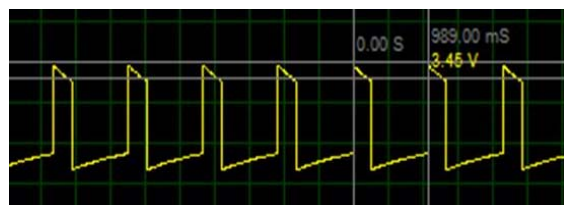

Fig. 10 HR for an adult

Fig. 11 represents the heartbeat rate of an athlete. It shows that the amplitude is 1.36V and time to complete one cycle is

1100 ms. Therefore, the HR is 55 bpm,

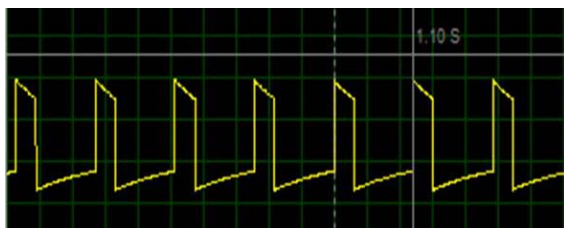

Fig. 11 HR for an active athlete

Several case studies are shown based on our designed HR measurement (HRM) system. According to the data provided in Table I of HR for different aged person, we found that the results achieved through these simulations are approximately same.

V. CONCLUSION

We have designed and simulated a simple and easy to implement heart rate measurement machine based on a microcontroller with a very nominal implementation cost. The system will be portable if implemented and no on-site medical personnel are required to monitor the HR of any patient at any time. The patient can then send his/her HR data to the physicians for treatment purposes from any village or town whatever the distance between the patient and doctors may be. However, there are a few scopes for further development or improvement of this designed system. We recommend the following future plans for this system:

- To implement the complete circuit with an LCD screen
- To design a rechargeable battery for the system.
- To develop a program for connecting it to the smartphone.
- To develop an application for the smartphone for real-time analysis.
- To design and implement the system on a PCB for housing it inside a box safely.
- To optimize the components and circuits to make more cost-effective, efficient and reliable.

However, through this work, our main goal was to provide a simple, portable, and cost-effective solution for the ECG signal monitoring and heart rate computation for the people of low- and middle-income groups.

REFERENCES

- [1] WHO Fact Sheet on Cardiovascular Diseases (CVDs): [https://www.who.int/en/news-room/fact-sheets/detail/cardiovascular-diseases-\(cvds\)](https://www.who.int/en/news-room/fact-sheets/detail/cardiovascular-diseases-(cvds)), accessed on 28 April 2020.
- [2] S. Edwards., "Heart Rate Monitor Book," *Leisure Systems International*, December 1993.
- [3] M. Malik and A. J. Camm., "Heart Rate Variability," *Futura Publishing Co. Inc.*, September 1995.
- [4] P. Leijdekkers and V. Gay. "A Self-Test to Detect A Heart Attack Using A Mobile Phone and Wearable Sensors," *Proceedings of the 21st IEEE International Symposium on Computer-Based Medical Systems*, p. 93, 2008.
- [5] M. K. Russel and M. H. Bhuyan, "Microcontroller Based DC Motor Speed Control Using PWM Technique," *Proceedings of the IEEE International Conference on Electrical, Computer and Telecommunication Engineering (ICECTE)*, RUET, Rajshahi, Bangladesh, 1-2 December 2012, pp. 519-522.
- [6] M. H. Bhuyan, M. M. Haque, M. A. Rauf and M. M. I. Khan, "Design and Implementation of a Microcontroller Based Elevator Control Systems," *Proceedings of the International Conference on Engineering Research, Innovation and Education (CERIE 2011)*, SUST, Sylhet, Bangladesh, 11-13 January 2011, pp. 504-507.
- [7] M. S. Ali and M. H. Bhuyan, "Design and Implementation of a Low-Cost Automated Blood Flow Control Device Through Smart Phone for Bio-Medical Application," *Proceedings of the IEEE International Conference on Informatics, Electronics and Vision (ICIEV 2017)*, University of Hyogo, Himeji, Japan, 1-3 September 2017, pp. 1-5.
- [8] M. S. Ali and M. H. Bhuyan, "Design and Implementation of a Low-Cost Blood Pressure Measuring Device," *Proceedings of the IEEE International Conference on Electrical and Computer Engineering (ICECE)*, BUET, Dhaka, Bangladesh, 20-22 Dec. 2018, pp. 309-312.
- [9] N. Chirakanphaisarn, T. Thongkanluang, Y. Chiwpreechar, "Heart rate measurement and electrical pulse signal analysis for subjects span of 20–80 years," *Journal of Electrical Systems and Information Technology*, vol. 5, 2018, pp. 112–120.
- [10] E. A. P. J. Prawiro, C.-I. Yeh, N.-K. Chou, M.-W. Lee and Y.-H. Lin, "Integrated Wearable System for Monitoring Heart Rate and Step during Physical Activity," *Journal of Mobile Information Systems*, Hindawi Publishing Corporation, Special Issue, Vol. 2016, Article ID 6850168, 10 pages, doi: <http://dx.doi.org/10.1155/2016/6850168>.
- [11] J. Arora, Gagandeep, A. Singh, N. P. Singh, S. S. S. Rawat and G. Singh, "Heartbeat Rate Monitoring System by Pulse Technique Using HB Sensor," *2014 IEEE International Conference on ICICES*, S. A. Engineering College, Chennai, Tamil Nadu, India.
- [12] M. H. Bhuyan and K. M. Rahman, "Digital Signal Processor Controlled PWM Phase Modulator for Two-Phase Induction Motor Drive," *Journal of Electrical Engineering*, the Institution of Engineers Bangladesh (IEE-EE), 0379-4318, vol. EE 34, no. I-II, pp. 19-25, Dec. 2007.
- [13] V. V. Stuchilin, V. A. Romyantseva and I. S. Svirin, "The Use of Digital Signal Processing Algorithms for Electrophysiological Diagnostics of Cardiovascular Diseases," *Biomedical and Pharmacology Journal*, Vol. 10, no. 1, pp. 119-128, 2017.
- [14] S. T. Prasad and S. Varadarajan, "PC Based Digital Signal Processing of ECG Signals," *International Journal of Advanced Research in Computer and Communication Engineering (IJARCC)*, Vol. 2, Issue 12, December 2013.
- [15] J. Justese and S. C. Madsen, "Wearable wireless ECG monitoring Hardware prototype for use in patients own home," *Proc. of IEEE Conference*, 2009, doi: 10.4108/icst.pervasivehealth2009.6.
- [16] G. C. Seng, S. Salleh, A. R. Harris, M. N. Jamaludin and I. Kamarulafizam, "Standalone ECG monitoring system using digital signal processing hardware," *Proc. of IEEE Conference*, January 2012.
- [17] H. Chang, J. Chen and Y. Liu, "Micro-piezoelectric pulse diagnoser and frequency domain analysis of human pulse signals," *Journal of Traditional Chinese Medical Sciences*, vol. 5, 2018, pp. 35-42.
- [18] A. Patil, A. Madankar and P. D. Khandait, "Heart Rate Monitoring System," *Proc. of 2019 5th IEEE International Conference on Advanced Computing & Communication Systems (ICACCS)*, pp. 574-576.
- [19] B. Cömert, A. İstanbullu and U. Turhal, "Low Cost and Portable Heartbeat Rate Measurement from the Finger," *Proc. of the 5th IEEE International Symposium on Sustainable Development (ISSD 2014)*, pp. 197-204.
- [20] T. Serevoravitgul and T. Kondo, "A Comparative Study for Heart Rate Measurement in Video Sequences," *Proc. of the 2015 12th International Conference on Electrical Engineering/Electronics, Computer, Telecommunications and Information Technology (ECTI-CON)*, 24-27 June 2015, Hua Hin, Thailand.
- [21] Y. Lee, J.-Y. Park, Y.-W. Choi, H.-K. Park, S.-H. Cho, S. H. Cho and Y.-H. Lim, "A Novel Non-contact Heart Rate Monitor Using Impulse-Radio Ultra-Wideband (IR-UWB) Radar Technology," *Springer Nature, Scientific Reports*, 2018, pp. 1-10, doi:10.1038/s41598-018-31411-8.
- [22] M. H. Bhuyan, M. T. Hasan and H. Iskander, "Low Cost Microcontroller Based ECG Machine," *International Journal of Biomedical and Biological Engineering*, vol. 14, no. 7, 2020, e-ISSN : 1307-6892, pp. 192-199.
- [23] A. Malvino and D. J. Bates, "Electronic Principles." 7th edition, *Tata McGraw-Hill Publishing Company Limited*, New Delhi, India, 2011, pp. 203-223.



Muhibul H. Bhuyan (MIEEE'07-) became a Member (M) of World Academy of Science, Engineering and Technology in 2005, born in Dhaka, Bangladesh on 25 July. He did his BSc, MSc and PhD degrees in Electrical and Electronic Engineering (EEE) from Bangladesh University of Engineering and Technology (BUET), Dhaka, Bangladesh in 1998, 2002 and 2011 respectively.

Currently, he is working as the Professor and Chairman of the Department of Electrical and Electronic Engineering of Southeast University, Dhaka, Bangladesh. Previously, he worked at Green University of Bangladesh, Dhaka as a Professor and Chairman of EEE Department; Daffodil International University, Dhaka, Bangladesh as an Assistant Professor and Head of ETE Department; Presidency University, Dhaka, Bangladesh as an Assistant Professor and American International University Bangladesh (AIUB), Dhaka as a Faculty Member since June 1999. He also worked as a Researcher in the Center of Excellence Program of Hiroshima University, Japan from July 2003 to March 2004. So far, he has published over 40 research papers at national and international journals and presented over 50 research works at national and international conferences. His research interests include MOS device modeling, biomedical engineering, control system design; outcome based engineering education, its assessment and evaluation.

Prof. Bhuyan is the Member of IEEE, USA, Executive Member of Bangladesh Electronics and Informatics Society (BEIS) and Fellow of the Institution of Engineers Bangladesh (IEB). He is a regular reviewer and technical/editorial/organizing committee member of several national and international journals and conferences. He was the Organizing Chair of the recently held IEEE 22nd International Conference on Computer and Information Technology (ICCIT) in Dhaka, Bangladesh during 18-20 December 2019. He is the recipient of the Bangladesh Education Leadership Awards (Best Professor in Electrical Engineering) in 2017 from South Asian Partnership Awards, Mumbai, India.



Mafujul Hasan was born in Bogra district, Bangladesh on 5th October. He completed his BSc degree in Electrical and Electronic Engineering (EEE) from Southeast University, Tejgaon I/A, Dhaka, Bangladesh in 2019.

Currently, he is working as a Research Student in the Department of Electrical and Electronic Engineering of Southeast University. His research interest includes biomedical engineering and system development.