

Review of Strategies for Hybrid Energy Storage Management System in Electric Vehicle Application

Kayode A. Olaniyi, Adeola A. Ogunleye, Tola M. Osifeko

Abstract—Electric Vehicles (EV) appear to be gaining increasing patronage as a feasible alternative to Internal Combustion Engine Vehicles (ICEVs) for having low emission and high operation efficiency. The EV energy storage systems are required to handle high energy and power density capacity constrained by limited space, operating temperature, weight and cost. The choice of strategies for energy storage evaluation, monitoring and control remains a challenging task. This paper presents review of various energy storage technologies and recent researches in battery evaluation techniques used in EV applications. It also underscores strategies for the hybrid energy storage management and control schemes for the improvement of EV stability and reliability. The study reveals that despite the advances recorded in battery technologies there is still no cell which possess both the optimum power and energy densities among other requirements, for EV application. However combination of two or more energy storages as hybrid and allowing the advantageous attributes from each device to be utilized is a promising solution. The review also reveals that State-of-Charge (SoC) is the most crucial method for battery estimation. The conventional method of SoC measurement is however questioned in the literature and adaptive algorithms that include all model of disturbances are being proposed. The review further suggests that heuristic-based approach is commonly adopted in the development of strategies for hybrid energy storage system management. The alternative approach which is optimization-based is found to be more accurate but is memory and computational intensive and as such not recommended in most real-time applications.

Keywords—Hybrid electric vehicle, hybrid energy storage, battery state estimation, state of charge, state of health.

I. INTRODUCTION

THE energy storage technologies have become important to the sustainability and feasibility of developing an efficient electric grid system and especially in the Transport Vehicle (TV) applications. [1]. The air-quality constraints which have become even more stringent in the last few decades and the fact that the world's fossil supply will eventually deplete have raised conscientious effort to limit the greenhouse gas emission [2], [3]. Human demand for energy is constantly growing while fossil fuel reserves are continuously being depleted. Effort is on the rise to reduce fossil fuel consumption and greenhouse effect, by exploring renewable energy sources [4]-[6]. Strategic direction for the international energy industry therefore puts emphasis on the progress of alternative energy technologies that support energy system upgrade and diversification of utilization [1], [7].

EV and hybridization are set to play an important role in the

combat against the danger of greenhouse gas emissions by offering clean and a more efficient energy system alternative [4], [8]. The success of these applications however depends mainly on the performances of the energy storage system parameter metrics such as high energy and power densities, life cycle, fast charge times, cost, weight and safety concerns [8]. The energy storage system (ESS) is pivot to a successful application of efficient commercialized clean EV. EV performance is significantly influenced by the efficiency of the ESS [5], [9].

The Lead-Acid battery is considered in the literature [1], [7], [5] as the most mature battery technology at this moment. It has dominated the medium voltage Micro Grid (MG) industry as the established storage device. EV was first developed shortly after the invention of a lead-acid batteries however, EVs almost disappeared, giving the automotive market to ICEVs [1], [6], [9], [10]. This was mainly due to the limitations of battery the heavy weight, long charging time, high cost [6], short trip range and poor durability of ESS at that time.

The EVs' ESS are required to handle high energy and power density capacity constrained by limited space, weight and at relatively low cost [8], no single ESS at the moment can fulfil all the requirements [11], [12]. The high energy density batteries such as nickel-metal hydride and lithium-ion (Li-ion) technologies have been used to deliver EV high energy and power density requirements. To make the EV more commercially viable, several hybridization topologies of Li-ion batteries with supercapacitors have been proposed by different researchers [5], [25], [29].

Extensive research efforts and investments have created advancements in battery and supercapacitor hybrid technologies with higher combined energy and power than ever previously thought possible and are now relatively suitable for EVs all over the world [11]. This approach allows making a compromise of a high-power density and high-energy density power supply, resulting in significant performance improvements of EV [8].

It has been established that hybrid energy storage system (HESS), which utilizes the advantageous attributes of different ESS, has better economic and system features than other storage systems and has exponentially increased in different applications such as being experienced in the electric hybrid vehicles [13], [14]. It was claimed in [15] that combining a conventional battery with a supercapacitor in a common electrolyte produced an improved performance.

EV technologies, energy storage technologies and its efficient management development and advancement are the

Kayode Olaniyi is with the University of Johannesburg, South Africa (e-mail: olaniyikayodeade@gmail.com).

most crucial sectors to the automotive industries. It is yet driven by attempts to cut down on gas emission and on challenges of the global economy [16].

Energy Storage Management System serves as the intelligent connecting link between the energy storage and the vehicle, playing a pivotal role in optimizing the battery and vehicle operation in reliable and safe conditions. In view of the rapid growth of the EV and Hybrid Electric Vehicle (HEV) market, it is urgently important to develop more robust ESS and energy management that keeps with the challenges of the growth.

Li-ion application as energy storage in EV is very promising leading to increasing attention now paid to the commercial Li-ion battery. The challenge to overcome the associated drawbacks of poor temperature performance, energy density, and high electrode costs are [7] impetus for more research into battery state evaluation and technologies. Different methods for battery state estimation are available. The State-of-Charge, State-of-Function and State-of-Health are therefore extensively been discussed and analyzed by many authors and researchers [17].

This paper reviews the energy storage technologies and it discusses the various battery modelling and evaluation approaches in the literature. Also the different strategies for intelligent energy storage management schemes in EV applications are studied. The review also discusses current challenges regarding hybrid energy storage charge and discharge control in EV applications.

II. ENERGY STORAGE TECHNOLOGIES.

The fascinating growth in clean and renewable energy to every corner of the world is essential for the global sustainability. The development of pollution-free automotive system such as the EV as a replacement for Internal Combustion Engine (ICE) vehicles [6] is therefore significant to such sustainability. The greenhouse gas emissions issues, complimented by the increase in prices of gasoline and the

continuing development in battery technology, EVs and HEVs are gradually becoming viable alternative transportation means [5]. From portable electronics to EVs and HEVs, batteries and hybrid batteries are widely used as main energy source in many of these applications. The choice of battery or hybrid batteries used as energy storage and the method of control of the energy storage management are significant to the efficiency and the viability of the EV.

A wide range of electrical energy storage (EES) devices currently exist, and many have been in operation for decades [18]. They are classified into mechanical, electrochemical, chemical, electrical and thermal ESS. Fig. 1 represents various categories of ESS.

Batteries are the first electrical ESS to be introduced and have remained an important constituent of ESS. The electrochemical rechargeable batteries are commonly used as energy storages in EV applications and they play critical role in its performance and reliability [16]. Batteries are required to store excess energy generated during low power consumption periods, and to readily make available the stored energy when it is required [1], [14].

Batteries are typically known to have high energy and low power densities. The high energy density of typical battery implies that it is capable of providing steady-state current for a long period of time. The low power density battery attribute however restricts its ability to provide transient changes in power demands [13], [14]. In a HESS, batteries play an important role to store and release energy when it is required [14]. The Lead-acid, Ni-MH and the Lithium batteries coupled with supercapacitors are the three mainly used batteries in EVs HESS [16], [19], [20]. New technologies are constantly being developed to solve the difficult problems in battery energy which may in turn impede battery applications [7]. The performance metrics which are major attributes of comparison for ESS are: the energy, the power densities, the cycle life, calendar life, and the cost per kWh [6], [21].

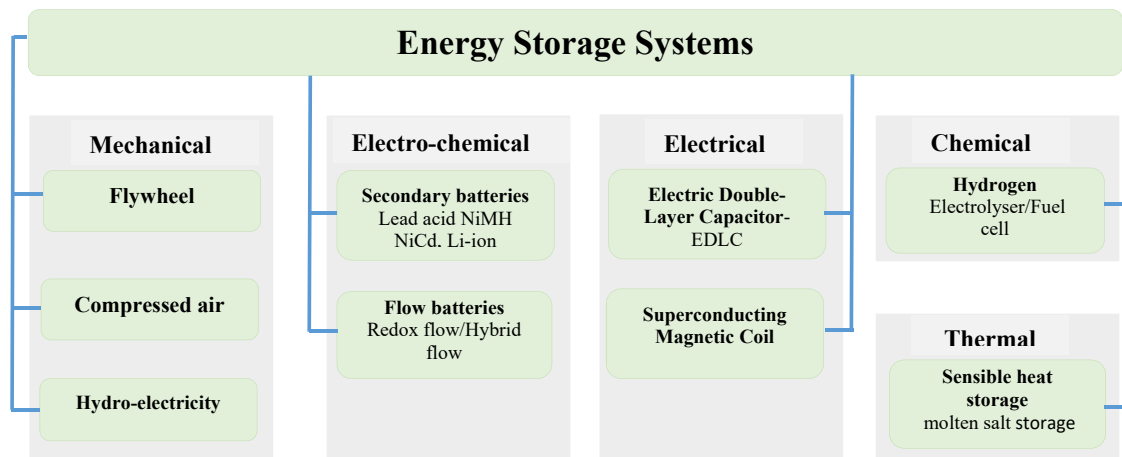

Fig. 1 The categories of ESS

This section of the study presents a review of the advancements in energy storage technologies. The commonly

used energy storage characteristics, advantages and drawbacks are also reviewed and presented.

A. Lead-Acid Battery

The lead-acid battery is the oldest type of rechargeable battery commonly used in automotive industry for lighting, starting and igniting (SLI) due to its safety, economy and almost no heat effect [16]. It is of low specific energy density typically between 20 and 40Wh/kg and has been adopted in many applications for which costs represent an issue [1]. The lead-acid battery typical life cycle of less than 1000 full-cycles may be considered as short compared to other technologies such as Ni-MH [22]. However, voltage regulated Lead acid battery technology is currently reported in [16] as having a life-cycle between 2000 – 4500 cycles. The lead-acid batteries offer the most inexpensive energy capacity and are the most prominent choice in medium voltage renewable storage applications. The valve regulated lead-acid (VRLA) batteries have been implemented in small range HEV applications [16], but Li-ion is commonly preferred as they last significantly longer and weigh less [10], [23].

B. Li-Ion Batteries

Li-ion battery technology is considered as the most promising energy storage technology for automotive electronics and EV or HEV applications with considerable hope for improvement [3], [16], [24]. This is according to most of the reports in the literature indicating the Li-ion technology is more studied in detail among others. It has high energy density, high efficiency and a long life cycle [6], [25].

Li-ion batteries have a number of advantages over the other two popular types of batteries (such as lead-acid, NiCd or NiMH) and have received great attention in EVs application [10], [17]. This is because of its relatively impressive characteristics like, fast charging, high energy density, lightweight, high cycle of life and low self-discharge [10], [20].

Li-ion batteries have been reported in [18] to have the highest power density compared to all other commercial batteries. They especially perform well if they are operated using an effective battery management system making them more attractive for automotive or aircraft applications. Li-ion battery technology has been developed to meet different application requirements, and is adjudged as the most widely used battery technologies in advanced EV [26]. However the possibility of the large size for a plant is not very high [18].

The commercial Li-ion battery in spite of its advantages and promises also has its drawbacks. The drawbacks are: poor temperature performance, cycling performance, capacity, energy density, decreased longevity, difficult storage, and high electrode costs [7], [18], [27]. The thermal behavior of a Li-ion battery can be strongly affected by electrochemical and chemical processes. This may occur inside the cell during charge and discharge and lead to significant losses in subzero-temperature environments. This is because of reduced energy and power capabilities as well as severe battery degradation due to lithium plating.

C. Supercapacitor

Supercapacitors (SCs), or ultracapacitors, have been developed since about 1990 and are currently evolving as promising emerging field of energy storage technology. The SCs also known as Electric Double Layer Capacitor (EDLC) unlike in the batteries utilize static charge for energy storage [24], [28].

The SCs or the EDLC are generally of two types. The first type involves the storage of charge in the electrical double layer at or near the electronic material interface or electrolyte known as the ultracapacitor. The second type is known as the SC, which utilizes the transient additional reversible absorption of atomic species, within the crystal structure of the electronically conducting compact electrode [10].

The SCs are usually used to supply burst currents at ranges that are considered harmful to conventional battery in the EVs. The batteries are however used as the main energy supply to recharge the SC capacitor as well.

SCs generally have high power density, high life-cycle, higher charge-discharge efficiencies, wide operating temperature range, and completely free maintenance [29]. As a result of its low internal resistance [25], it can afford to deliver large transient power. This is achievable without generating a significant amount of heat or voltage drop. It permits frequent cycling of charge and discharge and a higher charge and discharge current. However, SC is known to have higher costs and self-discharging rates. While the current battery technologies may not permit more than tens of thousands of charge and discharge cycles, the lifetime of SCs is reported to be over half a million cycles [30].

According to [31], among different types of SCs, the promising one is hybrid SCs that utilize “both faradaic and non-faradaic” processes to store charge, with characteristic energy and power densities greater than EDLC's are emerging. The characteristics of the hybrid SCs are at the top of other types. Table I offers the comparative characteristics of the battery and SC.

TABLE I
CHARACTERISTICS OF BATTERY AND SCs [24]

	Battery	SC
Charging time	Several hours	Fraction of seconds to minutes
Self-discharging time	Weeks to few	Hours to days
Energy density	10-100Wh/kg	<5Wh/kg
Power density	<500 W/kg	>1000W/kg
Charging/discharging	70-85%	85-98%

III. BATTERY MODELLING

The complicated electrochemical mechanism of batteries has made the development of a battery model a difficult task [3], [34]. The battery state estimation modelling is presented with special attention to its EVs applications. Battery modeling and state estimations are commonly developed from mathematical, electrochemical and equivalent circuit models. The model can be defined using a set of equations under specific conditions of interest. The choice of equations, or the mathematical description of batteries, is significant in

predicting the behaviour of the system [5]. The EV range prediction for instance is only possible through accurate battery model and state estimation that determines SoC just

like the fuel gauge in ICEVs to predict remaining capacity [26]. Figs. 3 and 4 respectively represent typical battery model and its equivalent circuit.

TABLE II
PERFORMANCE COMPARISON AMONG VARIOUS ENERGY STORAGE DEVICES

	Energy [Wh/kg]	Power [W/kg]	Temp [°c]	Cycle efficiency	Life cycle	Cost per capacity [\$/kWh]	Self-discharge [% month]
Lead Acid	20-40 8-600 [32]	100-300 [5], [10], [20]	-30-60	85	200-300 [20], [23] 1000 [22] ~2000 [18] 2000 – 4500 [16]	150	2-8
NiMH	40-60	500-1300 150-300 [16]	-20-50 -40-50 [16]	75-85 [16]	> 2500 2000-3000 [16]	500	20
Li-ion	100-200 [5], [20]	800-3000 [20] 28000 [11]	-20-55	93	< 2500	800	1-5 10 [15]
SC	1-5[20]	1500 [20] 1000-10000 [10], [11], [33]	-30-65	97	100,000-1M [10], [11], [15], [22]	2000	30

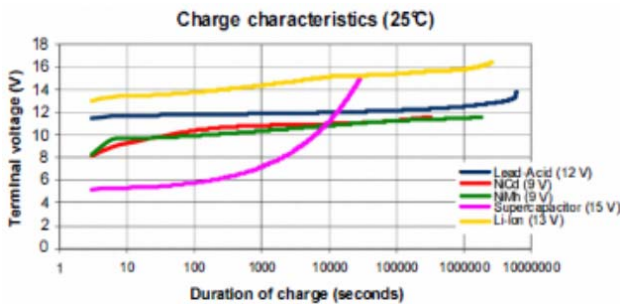

Fig. 2 Charging characteristics of Lead-Acid, Ni-Cd; Ni-Mh; Li-Ion (UR I 86S0F) and BPAK03S0- IS (2S°C) [25]

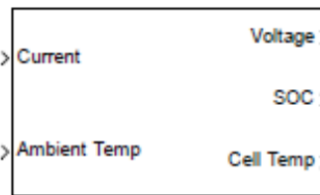

Fig. 3 Battery model [35]

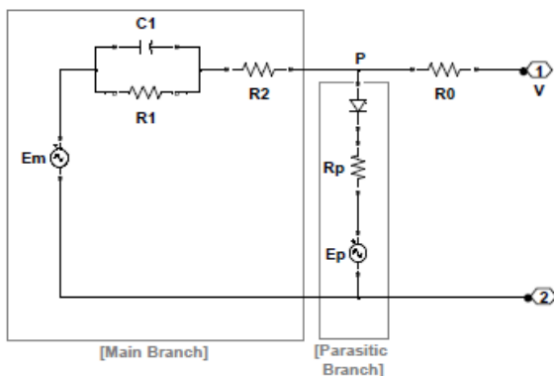

Fig. 4 Battery Equivalent circuit [35]

In [36] the model is “based on a modified Shepherd curve-fitting model. The additional term (voltage polarization) is added to the battery discharge voltage expression to better represent the effect of the battery SOC on the battery

performance. In addition, to ensure the simulation stability, a filtered battery current instead of the actual battery current, is used to account for the polarization resistance”.

IV. BATTERY STATE EVALUATION

The accurate estimation of battery states in EV, such as State-of-Charge (SoC), State-of-Available-Power (SoAP) or State-of-Health (SoH) [37] and State-of-Life (SoL) is still a challenging task for researchers [17]. Battery models are essential to estimate the lifetime accurately under various battery conditions of operation [38]. Fig. 5 shows the different battery states and parameter metrics.

A. State-of-Charge (SoC)

The SoC is considered crucial and is probably one of the most challenging topics in the battery research in battery management system [39]. And because of its significant effect on battery behaviour it is the most widely used variable in battery modeling. The hybrid battery SoC in EVs is analogous to fuel gauge in ICEVs [3] but unfortunately the onboard sensing technology currently available does not make provision for direct measurement [20]. The ratio of the remaining capacity to the maximum capacity can be expressed as SoC, which is calculated by (1):

$$SOC(\%) = \frac{Q_m - \int I dt}{Q_m} \times 100\% \tag{1}$$

There are a wide range of approaches proposed in the literature for SoC estimation [31], [41], [39] some of which are the ampere-hour counting, Open-Circuit Voltage (OCV)-based, impedance-based, model-based and fuzzy-logic based estimation. It is noted that to date most SoC determination is still based on empirical evaluation involving capacity measurements. The accuracy of the empirical approach was however questioned in [39] raising issues of the battery safety and reliability. Fig. 6 represents the categories of SoC estimation methodologies.

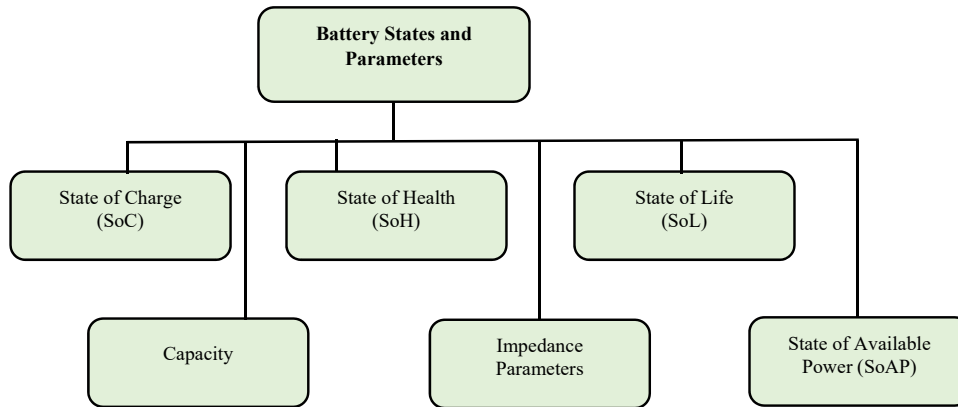

Fig. 5 The battery states and parameter metrics

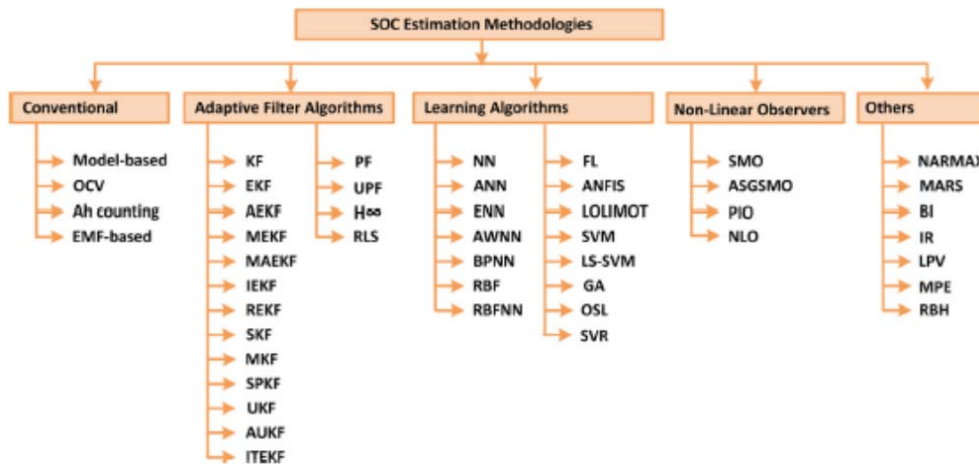

Fig. 6 Categorization of SoC estimation methodologies [38].

TABLE III
DIFFERENCE BETWEEN EXPERIMENTAL TECHNIQUES AND ADAPTIVE METHODS [40]

SoH Estimation		
	Experimental techniques	Adaptive methods
Based on	Storing the lifetime data and the use of the previous knowledge of the operation performance of the cell/battery.	Calculations of the parameters, which are sensitive to the degradation in a cell/battery.
Advantages	<ol style="list-style-type: none"> 1. Low computational effort 2. Possible implementation in a BMS 	<ol style="list-style-type: none"> 1. High accuracy 2. Possible to be used in situ estimation
Drawbacks	<ol style="list-style-type: none"> 1. Low accuracy 2. Not suited for situ estimation 	<ol style="list-style-type: none"> 1. High computational effort 2. Difficult in BMS implementation

TABLE IV
REVIEW OF THE MOST USED SOH ESTIMATION TECHNIQUES [40]

Method	Reason	Improvement	Effect/requirement
Coulomb Counting	<ol style="list-style-type: none"> 1. Simplicity 2. Practical 3. Fast 	<ol style="list-style-type: none"> 1. With other method supporting for: SoC estimation and updates 	<ol style="list-style-type: none"> 1. When applying other method, the main advantages are gone: simplicity and response velocity
Kalman Filter	<ol style="list-style-type: none"> 1. Accurate 2. Error bounds 	<ol style="list-style-type: none"> 1. For simple systems, not controlling lot of variables 2. For keeping under control the main problematic parameter 	<ol style="list-style-type: none"> 1. If the performance changes, it is not contemplated
Extended Kalman Filter	<ol style="list-style-type: none"> 1. Accurate 2. Error bounds 3. Valid for non-linear systems 4. Very used 	<ol style="list-style-type: none"> 1. Need powerful controllers. 2. For mature technologies in order to adapt the filter for the performance already studied. 	<ol style="list-style-type: none"> 1. Need time for researching the chemistry and improving the controller
Observers	<ol style="list-style-type: none"> 1. Possible for all chemistries 2. Faster than KF 	<ol style="list-style-type: none"> 1. For mature technologies 2. Need powerful controllers 	<ol style="list-style-type: none"> 1. Need time for researching the chemistry and improving the controllers.
Least squares	<ol style="list-style-type: none"> 1. Precise 2. Robust 	<ol style="list-style-type: none"> 1. For mature technologies 2. Need powerful controllers 	<ol style="list-style-type: none"> 1. Need time for researching the chemistry and improving the controllers.

B. SoH

SoH reflects present physical condition expressed by internal behavior of the battery such as loss of rated capacity, to external behavior, such as severe conditions. The SoH is the reflection of the health condition of a battery and its ability to deliver specified performance compared to a new battery [34]. The SoH can be used to determine battery cell degradation to forestall possible failure of vehicle electric power system [40].

$$SOH(\%) = \frac{Q_m}{Q_{nom}} \times 100\% \quad (2)$$

For a new battery, the SoH ranges within 0–100%, however this changes as the battery ages [3]. It was stated in [41] that the a Li-ion battery life for instance, is commonly defined by the maximum cycles when the SoH drops to 80%. And SoH is consequently a major indicator of battery safe operation providing a timely replacement warning. The SoH battery state evaluation can be achieved majorly by experimental and adaptive methods [40].

C. SoL

This is defined as the Remaining Useful Life (RUL) of a battery. It is a predicted period of time until the battery characteristic reaches the threshold point defined as the end of life of the battery [3]. According to [34], accurate SoL predictions will aid failure prevention and maintenance, to prolong the service life of batteries. The author also claims that so far there are limited work done on the prediction of SoL. However the ever increasing demand for battery reliability, especially in military products as well as in the EV applications, has continued to encouraged research and development of state-of-the-art algorithms [34].

V. HESS MODEL

The ESS comprising of battery and SCs hybrid are a promising solution to optimizing EV battery lifetime [30]. In the study of energy management strategies, it is crucial to understand the system behavior to be able to develop a full and quite accurate model of each subsystem components. This helps in decision making that allows for an effective control design strategy of the energy management system [13], [36].

There are three basic configurations of a hybrid battery–SC energy storage as reported in the literature: passive, semi-active and fully active connection [42] and, they are designed to meet specific objectives. The objectives are constant monitoring of the battery states of charge and voltage to determine the ability of the battery to deliver its specified output and RUL [16], [30]. The second objective will be to ensure that the battery operates efficiently and at the safe range such that the battery is not damaged [6].

The optimal design of the setup topologies between different energy storage devices in HESS is critical to its overall efficiency [24]. The effective power dispatch among different energy subsystems is usually a major challenge. The primary objective is to produce energy storages with high energy density to balance steady-state power mismatch, while

high power density compensates for high frequency transient power [43]. HESS is a remedy for the battery degradation due to frequent charge/discharge cycles [15] and also for effective utilization of energy.

To study the behaviour of EV power management strategies and the problem of optimizing charging, the power supply of the drive trains, the hybrid energy storage need to be accurately modeled and emulated as well [8]. HESS should contain accurate algorithms to measure and estimate the functional status of the energy storage and, at the same time be equipped with state-of-the-art mechanisms to protect the battery [34].

HESS in the EV may consist of many components such as transducers, controller, actuators which are controlled by many models, algorithms, and signals [20]. Different control strategies have been proposed to manage energy in hybrid energy systems [44] for automotive applications.

The two major approaches that have been identified in the literature for energy management systems are; the rule-based and the optimization-based approaches. The optimization-based uses λ -control strategies and is reported with best performance but is considered not suitable for real-time applications. This is mainly because of its associated high memory and computational requirements [30]. There are however reported cases of hybrid energy storage management approach where both optimization-based and rule-based approaches are utilized.

In the literature most HESS control algorithms are rule-based approach. It is realized by filtering-based centralized control system where net power is either passed through high-pass or low-pass filter to generate power references for different Energy Storage [43]. The strategy is such that low-frequency current is directed to the battery while the high-frequency part is supplied to the SCs [30]. In [13] low-pass filters are used to determine the HESS power and realize the energy distribution between different energy storage mediums according to the principle of fuzzy control.

In [24] a software approach using Support Vector Machine (SVM) pattern classifier to decide the switch of energy sources, depending on the load requirement was adopted. The SVM is a supervised learning system that allows the prediction of the load demand before it occurs resulting in the reduction in delay of power delivery. Fig. 7 represents the basic framework of the energy management in EV adopted in [20].

For an effective energy storage management system, certain other requirements apart from battery characteristics are to be met by the battery monitoring algorithm [3]. Fig. 8 summarizes the expected monitoring algorithm requirements.

The HESS mathematical model is a mathematic expression that describes the charge and discharge process under the condition of a given operation constraint [13].

Charging process:

$$E(t) = (1 - \sigma_{ES})E(t - \Delta t) + P_{ES}(t)\Delta t\eta_{ES,C} \quad (3)$$

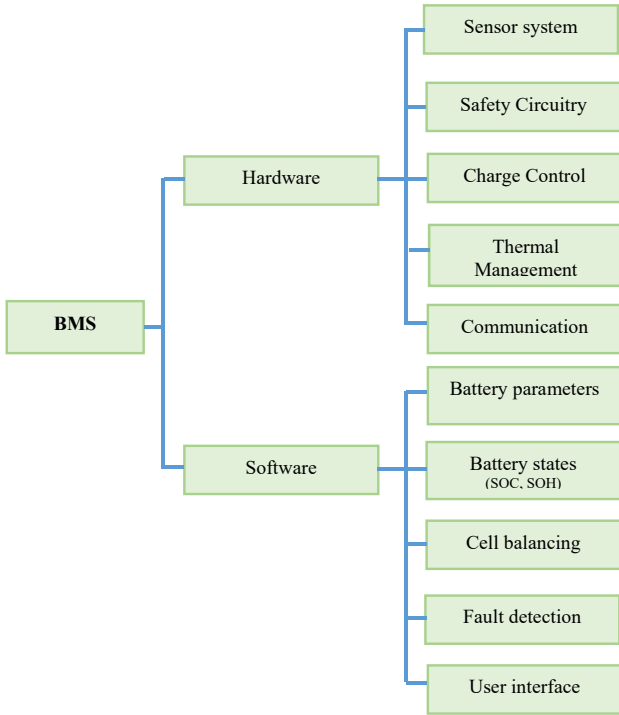

Fig. 7 Basic framework of BMS in EV [20]

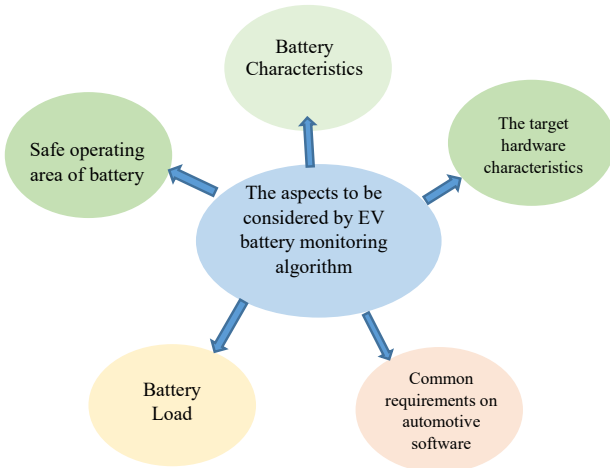

Fig. 8 Requirements on battery monitoring algorithms [3]

Discharging Process:

$$E(t) = (1 - \sigma_{ES})E(t - \Delta t) + \frac{P_{ES}(t)\Delta t}{\eta_{ES,D}} \quad (4)$$

Constraint:

$$|P_{ES}(t)| \leq |P_{ES,limit}(t)| \quad (5)$$

where $E(t)$ is the remaining energy of the storage medium at time t , MW·h; σ_{ES} is self-discharge rate, %/min; $P_{ES}(t)$ is storage medium power at time t , MW; Δt is sampling interval, min; $\eta_{ES,C}$ and $\eta_{ES,D}$ are charge and discharge efficiency, %;

$P_{ES,limit}(t)$ is the maximum allowable power at time t , MW, decided by characteristics of the storage medium and the remaining energy at time t

$$|P_{ES,limit}(t)| = \min \left\{ P_{max,C}, \frac{E_{max} - (1 - \sigma_{ES})E(t - \Delta t)}{\eta_{ES,C}\Delta t} \right\} \quad (6)$$

$$|P_{ES,limit}(t)| = \min \left\{ P_{max,D}, \frac{[(1 - \sigma_{ES})E(t - \Delta t) - E_{min}]\eta_{ES,D}}{\Delta t} \right\} \quad (7)$$

where $P_{max,C}$ and $P_{max,D}$ are the maximum charge and discharge power of the storage medium, respectively, MW; E_{max} and E_{min} are the maximum and minimum allowable capacity, MW·h.

VI. CONCLUSION

ESS are the core energy sources in EV applications and their performance greatly impacts the stability and reliability of EV. Manufacturers and researchers therefore are seeking for breakthroughs in both hybrid energy storage technologies and intelligent energy management strategies. This paper presents the developing energy storage technologies in view of their parameter metrics and the estimation strategies deployed in hybrid battery EV. This review also extensively discusses the different strategies for hybrid energy storage management for an efficient and reliable operation.

The review suggests that Li-ion is more favored and used more than any other energy storage device in EV. Many research activities therefore are on-going to improve on the technologies. However despite the advances recorded in battery technologies there is still no cell which possesses both the optimum power and energy densities among other requirements for EV application. Considerations for hybrid energy storage are becoming a promising solution to addressing the battery drawbacks.

The SC or the EDLC is identified as an evolving energy storage with very high power capacity and cycle life. It is used in hybrid energy storage management to balance the battery low power density challenge in EV application. It is noteworthy that there are disparities in the ranges of battery parameter metric values reported in the literature.

This review also identifies among many other battery estimation techniques, the importance of the SoC. The SoC determines remaining capacity and provides insight to charging/discharging strategies of the battery and, by extension the EV safety and reliability. There are therefore research activities on-going investigating the battery SoC estimation technique. The conventional measurement methods are considered inaccurate as they are highly affected by the battery age, the ambient temperature and other external disturbances. The literature [1], [5], [12], [39] recommends a SoC evaluation system that uses adaptive filter algorithm under various disturbances and uncertainty models. The adaptive filter algorithm is also however characterized by high computation burden and are therefore not computational efficient.

The review further underscores the importance of control strategies for energy storage management system in achieving

efficient power flow and reliable operation. The two major strategies that have been identified in the literature are; the rule-based and the optimization-based approaches. It is identified that optimization-based approach using λ -control strategy for HESS management is more robust compared to the heuristic-based approach, but the disadvantages are the high memory requirement and computational cost. The optimization-based approach is therefore not recommended in real-time applications.

There are however instances recorded in literature where optimization and the rule-based approaches are both combined. It is not clear whether this approach would solve the delay problem and be fast enough to be recommended for real-time applications. A promising solution to HESS control strategy delay in the real-time application is the predictive control algorithm like the SVM. The SVM is a supervisory training algorithm that can predict charge and discharge patterns in the control strategies therefore eliminating delay. This advantage is also at a cost which is the large memory requirement. The future works should therefore concentrate to overcome these challenges.

REFERENCES

- [1] Boicea, V.A., *Energy Storage Technologies: The Past and the Present*. Proceedings of the IEEE, 2014. 102(11): p. 1777-1794.
- [2] Garcia, J., et al., *A novel approach for global environmental performance evaluation of electric batteries for hybrid vehicles*. Journal of Cleaner Production, 2017. 156: p. 406-417.
- [3] Waag, W., C. Fleischer, and D.U. Sauer, *Critical review of the methods for monitoring of lithium-ion batteries in electric and hybrid vehicles*. Journal of Power Sources, 2014. 258: p. 321-339.
- [4] 4Hu, K.W., P.H. Yi, and C.M. Liaw, *An EV SRM Drive Powered by Battery/Supercapacitor With G2V and V2H/V2G Capabilities*. IEEE Transactions on Industrial Electronics, 2015. 62(8): p. 4714-4727.
- [5] Wang, Q., et al., *A critical review of thermal management models and solutions of lithium-ion batteries for the development of pure electric vehicles*. Renewable and Sustainable Energy Reviews, 2016. 64: p. 106-128.
- [6] Mahmoudzadeh Andwari, A., et al., *A review of Battery Electric Vehicle technology and readiness levels*. Renewable and Sustainable Energy Reviews, 2017. 78: p. 414-430.
- [7] Li, Y., J. Yang, and J. Song, *Efficient storage mechanisms and heterogeneous structures for building better next-generation lithium rechargeable batteries*. Renewable and Sustainable Energy Reviews.
- [8] Mesbahi, T., et al., *Dynamical modelling and emulation of Li-ion batteries–supercapacitors hybrid power supply for electric vehicle applications*. IET Electrical Systems in Transportation, 2016. 7(2): p. 161-169.
- [9] Jingshan, L., Z. Shiyu, and H. Yehui, *Review of Structures and Control of Battery–Supercapacitor Hybrid Energy Storage System for Electric Vehicles*, in *Advances in Battery Manufacturing, Service, and Management Systems*. 2017, Wiley-IEEE Press. p. 416.
- [10] Chotia, I. and S. Chowdhury, *Battery storage and hybrid battery supercapacitor storage systems: A comparative critical review*. in *2015 IEEE Innovative Smart Grid Technologies - Asia (ISGT ASIA)*. 2015.
- [11] Cohen, I.J., et al., *Evaluation of a Hybrid Energy Storage Module for Pulsed Power Applications*. IEEE Transactions on Plasma Science, 2014. 42(10): p. 2948-2955.
- [12] Adhikari, S., et al. *A battery/supercapacitor hybrid energy storage system for DC microgrids*. in *2016 IEEE 8th International Power Electronics and Motion Control Conference (IPEMC-ECCE Asia)*. 2016.
- [13] Sheng, S., et al. *A control strategy for hybrid energy storage system based on state of charge and variable filter coefficient*. in *International Conference on Renewable Power Generation (RPG 2015)*. 2015.
- [14] Samani, H. and X. Fernando, *Battery Current’s Fluctuations Removal in Hybrid Energy Storage System Based on Optimized Control of Supercapacitor Voltage*. IEEE Embedded Systems Letters, 2016. 8(3): p. 53-56.
- [15] Kim, Y., V. Raghunathan, and A. Raghunathan, *Design and Management of Battery-Supercapacitor Hybrid Electrical Energy Storage Systems for Regulation Services*. IEEE Transactions on Multi-Scale Computing Systems, 2017. 3(1): p. 12-24.
- [16] Hoque, M.M., et al., *Battery charge equalization controller in electric vehicle applications: A review*. Renewable and Sustainable Energy Reviews, 2017. 75: p. 1363-1385.
- [17] Farmann, A., et al., *Critical review of on-board capacity estimation techniques for lithium-ion batteries in electric and hybrid electric vehicles*. Journal of Power Sources, 2015. 281: p. 114-130.
- [18] Kim, J., Y. Suharto, and T.U. Daim, *Evaluation of Electrical Energy Storage (EES) technologies for renewable energy: A case from the US Pacific Northwest*. Journal of Energy Storage, 2017. 11: p. 25-54.
- [19] Wang, H., Q. Wang, and B. Hu, *A review of developments in energy storage systems for hybrid excavators*. Automation in Construction, 2017. 80: p. 1-10.
- [20] Hannan, M.A., et al., *A review of lithium-ion battery state of charge estimation and management system in electric vehicle applications: Challenges and recommendations*. Renewable and Sustainable Energy Reviews, 2017. 78: p. 834-854.
- [21] Pedram, M., et al. *Hybrid electrical energy storage systems*. in *2010 ACM/IEEE International Symposium on Low-Power Electronics and Design (ISLPED)*. 2010.
- [22] Gee, A.M., F.V.P. Robinson, and R.W. Dunn, *Analysis of Battery Lifetime Extension in a Small-Scale Wind-Energy System Using Supercapacitors*. IEEE Transactions on Energy Conversion, 2013. 28(1): p. 24-33.
- [23] Zheng, W., K. Ma, and X. Wang, *Hybrid Energy Storage with Supercapacitor for Cost-Efficient Data Center Power Shaving and Capping*. IEEE Transactions on Parallel and Distributed Systems, 2017. 28(4): p. 1105-1118.
- [24] Chia, Y.Y., et al., *A load predictive energy management system for supercapacitor-battery hybrid energy storage system in solar application using the Support Vector Machine*. Applied Energy, 2015. 137: p. 588-602.
- [25] Leuchter, J., P. Bauer, and V. Steklý, *Battery-supercapacitors mixed as electrical power buffers*. in *5th IET International Conference on Power Electronics, Machines and Drives (PEMD 2010)*. 2010.
- [26] Fotouhi, A., et al., *A review on electric vehicle battery modelling: From Lithium-ion toward Lithium-Sulphur*. Renewable and Sustainable Energy Reviews, 2016. 56: p. 1008-1021.
- [27] Capasso, C. and O. Veneri, *Integration between Super-capacitors and ZEBRA Batteries as High Performance Hybrid Storage System for Electric Vehicles*. Energy Procedia, 2017. 105: p. 2539-2544.
- [28] Cabrane, Z., M. Ouassaid, and M. Maaroufi, *Analysis and evaluation of battery-supercapacitor hybrid energy storage system for photovoltaic installation*. International Journal of Hydrogen Energy, 2016. 41(45): p. 20897-20907.
- [29] Mesbahi, T., et al., *Combined Optimal Sizing and Control of Li-Ion Battery/Supercapacitor Embedded Power Supply Using Hybrid Particle Swarm–Nelder–Mead Algorithm*. IEEE Transactions on Sustainable Energy, 2017. 8(1): p. 59-73.
- [30] Castaings, A., et al., *Comparison of energy management strategies of a battery/supercapacitors system for electric vehicle under real-time constraints*. Applied Energy, 2016. 163: p. 190-200.
- [31] Alguail, A.A., et al., *Battery type hybrid supercapacitor based on polypyrrole and lead-lead sulfate*. Journal of Power Sources, 2016. 313: p. 240-246.
- [32] Ju, F., et al. *Review of structures and control of battery-supercapacitor hybrid energy storage system for electric vehicles*. in *2014 IEEE International Conference on Automation Science and Engineering (CASE)*. 2014.
- [33] Nwesaty, W., A.I. Bratcu, and O. Sename, *Power sources coordination through multivariable linear parameter-varying/control with application to multi-source electric vehicles*. IET Control Theory & Applications, 2016. 10(16): p. 2049-2059.
- [34] Xing, Y.O., W.M. Eden, and K.L. Tsui, *Battery Management Ssystem in Electric and Hybrid Vehicles*. Energies, 2011. 4(1840-1857).
- [35] Jackey, R.A., *A Simple, Effective Lead-Acid Battery Modeling Process for Electrical System Component Selection*. 2007, SAE International.
- [36] Motapon, S.N., L.A. Dessaint, and K. Al-Haddad, *A Comparative Study of Energy Management Schemes for a Fuel-Cell Hybrid Emergency Power System of More-Electric Aircraft*. IEEE Transactions on Industrial Electronics, 2014. 61(3): p. 1320-1334.

- [37] Farmann, A. and D.U. Sauer, *A comprehensive review of on-board State-of-Available-Power prediction techniques for lithium-ion batteries in electric vehicles*. Journal of Power Sources, 2016. 329: p. 123-137.
- [38] Cuma, M.U. and T. Koroglu, *A comprehensive review on estimation strategies used in hybrid and battery electric vehicles*. Renewable and Sustainable Energy Reviews, 2015. 42: p. 517-531.
- [39] Li, Z., et al., *On state-of-charge determination for lithium-ion batteries*. Journal of Power Sources, 2017. 348: p. 281-301.
- [40] Berecibar, M., et al., *Critical review of state of health estimation methods of Li-ion batteries for real applications*. Renewable and Sustainable Energy Reviews, 2016. 56: p. 572-587.
- [41] Huang, S.-C., et al., *An online SOC and SOH Estimation model for Lithium-ion Batteries*. Energies, 2017. 10(512).
- [42] Ma, T., H. Yang, and L. Lu, *Development of hybrid battery-supercapacitor energy storage for remote area renewable energy systems*. Applied Energy, 2015. 153: p. 56-62.
- [43] Xu, Q., et al., *A Decentralized Dynamic Power Sharing Strategy for Hybrid Energy Storage System in Autonomous DC Microgrid*. IEEE Transactions on Industrial Electronics, 2017. 64(7): p. 5930-5941.
- [44] Jarushi, A.M. and N. Schofield. *Battery and supercapacitor combination for a series hybrid electric vehicle*. in *5th IET International Conference on Power Electronics, Machines and Drives (PEMD 2010)*. 2010.