

Experimental Investigation the Effectiveness of Using Heat Pipe on the Spacecraft Mockup Panel

M. Abdou, M. K. Khalil

Abstract—The heat pipe is a thermal device which allows efficient transport of thermal energy. The experimental work of this research was split into two phases; phase 1 is the development of the facilities, material and test rig preparation. Phase 2 is the actual experiments and measurements of the thermal control mockup inside the modified vacuum chamber (MVC). Due to limited funds, the development on the thermal control subsystem was delayed and the experimental facilities such as suitable thermal vacuum chamber with space standard specifications were not available from the beginning of the research and had to be procured over a period of time. In all, these delays extended the project by one and a half year. Thermal control subsystem needs a special facility and equipment to be tested. The available vacuum chamber is not suitable for the thermal tests. Consequently, the modification of the chamber was a must. A vacuum chamber has been modified to be used as a Thermal Vacuum Chamber (TVC). A MVC is a vacuum chamber modified by using a stainless mirror box with perfect reflectability and the infrared lamp connected with the voltage regulator to vary the lamp intensity as it will be illustrated through the paper.

Keywords—Heat pipe, thermal control, thermal vacuum chamber, satellite.

I. INTRODUCTION

THIS experimental work of was splitted into two phases: the development of the facilities and the actual experiments and measurements. Thermal control subsystem needs a special facility and equipment to be tested [1], [2]. The design of thermal control system has been done in purpose with using a non-space qualified material and test it in the TVC to see how close the results from the standard material. A MVC is a vacuum chamber modified by using a stainless steel mirror to distribute the heat fluxes uniformly around the thermal control system mockup. The variation of infrared lamp intensity simulates to be near or far from the sun. A connected cold plate with minimum temperature with -50°C simulates the shadow site of the earth.

II. HARDWARE DEVELOPMENT

A. Model Panels

A mockup box consists of 6 panels with dimension $50 \times 25 \times 25$ cm, 5 aluminium sheets and one honeycomb panel with 3 inserted heat pipes as shown in Fig. 1.

M Abdou is with the Space technology center, Cairo, Egypt. (phone: 00201277399677; fax: 002-320-5609; e-mail: omarmalekadam_2010@gmail.com).

M. K. Khalil is with Military technical college, Cairo, Egypt. (phone: 00201222454853; fax: 002-320-5609; e-mail: Khillo99@yahoo.com).



Fig. 1 Honeycomb panel

TABLE I
PANELS SPECIFICATIONS

Aluminum alloy AL 7075	
Density	2700 kg/m ³
Thermal conductivity	100 W/m.°C
Thermal capacity	850 J/kg.°C
Emissivity	0.85
absorptivity	0.17

B. Insulation

The design of thermal control system has been done in purpose with using a non-space qualified materials and test it in the TVC to see how close the results from the standard material. Glass wool insulation has been used instead of Multi-Layer Insulation (MLI) as shown in Fig. 2 to insulate the model and to keep the temperature inside the model at the operating temperature range.



Fig. 2 Glass wool insulation blanket with Aluminum foil facing

TABLE II
GLASS WOOL INSULATION SPECIFICATIONS

Geometrical properties	Width	0.25 m
	Length	0.5 m
	Thickness	0.02 m
Thermophysical properties	Thermal conductivity	0.038 W/m.k
	Density	40 to 70 kg/m ³
Temperature range	-60 °C to 120 °C	
combustibility	Non-combustible	

C. Flexible Foam Rubber Insulation Sheet

The foam rubber insulation sheet as shown in Fig. 3 has been used to assure the insulation between the contacts of the panels and it covered all the model panels also except the radiator area under the glass wool insulation.



Fig. 3 Flexible foam rubber insulation sheet

TABLE III
INSULATION SPECIFICATIONS

Geometrical properties	Width	0.25 m
	Length	0.5 m
	Thickness	0.02 m
Thermophysical properties	Thermal conductivity	0.033 W/m.k
	Density	50 kg /m ³
Temperature range	-80 °C to 400 °C	
combustibility	Non-combustible	

D. Heat Pipe

The heat pipe (Fig. 4) is used to distribute the temperature over the equipment panel [3], [4] and transfer the excessive heat through the radiator area outside the model [5].



Fig. 4 Heat pipe

E. Electrical Heaters

Electrical heaters as shown in Fig. 5 were used to simulate the heat dissipation from the equipment of the panel. Each electrical heater has different power according to the equipment which had been replaced. All the electrical heaters are controllable by using electrical sensors. The operating temperature range of the electrical heaters is from -20 °C to 40 °C.

F. Electrical Sensors

Electrical sensors as shown in Fig. 6 have been used to

control the operating temperature of the electrical heaters and to prevent the overheating of the electrical heaters if it operates longer than the designed periods [6], and to avoid the cooling because of low power heaters. Electrical sensors are distributed over the equipment panel in three zones over the three heat piped each zone has three sensors for the evaporating, condensing, adiabatic zones.



Fig. 5 Electrical heaters

TABLE IV
ELECTRICAL HEATERS SPECIFICATIONS

Electrical heaters	Electrical heaters are fixed over the equipment panel by thermal gasket gluing to grantee the higher thermal conductivity.
Geometrical properties	2 lyres from aluminium papers with 1.5 mm thickness. 10 cm Length 5cm width.
	Spacing between the two layers is from nickel chrome coils.
Electrical power	(8, 10,12) Watt for three electrical heaters.



Fig. 6 Electrical sensors

TABLE V
ELECTRICAL SENSOR SPECIFICATIONS

Electrical sensors	Specifications
Electrical sensors are fixed over the equipment panel by thermal gasket gluing to grantee the higher thermal conductivity and the accurate temperatures sensations.	Thermocouples t-types.
	Operates under very low pressure 10-6 bar.
	Operating temperature range from -100 °C to 200 °C.

G. Thermal Glue

Thermal glue as shown in Fig. 7 is used to fix the equipment over the equipment panel and insulation solar reflectors. The glue has a very high thermal conductivity to ensure the heat transfer between the contact surfaces.



Fig. 7 Thermal glue

H. Control Board

Control board, shown in Figs. 8, 9, is used mainly to control the switching on and off of the electrical heaters by using the input voltage of the electrical sensors.

TABLE VI
THERMAL GLUE SPECIFICATIONS

Thermal glue	Specifications
Thermal glue is used to contacting the electrical heaters, electrical sensors and all contacts used transfer heat.	High thermal conductivity. Operates under very low pressure 10-6 bar. Operating temperature range from -200 °C to 300 °C

Fig. 9 shows the control board components as follow:

- 6 sensors ports.
- 6 relays with variable resistance to adjust the sensor operating temperatures range.
- 6 electrical heaters ports that can give the heaters the required power.

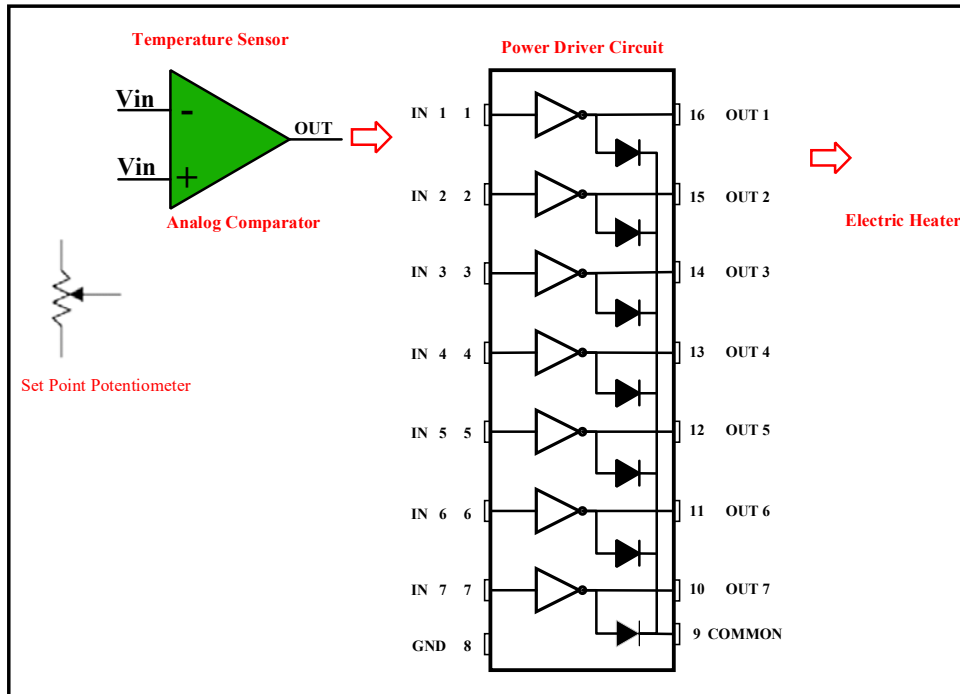

Fig. 8 Control board scheme diagram

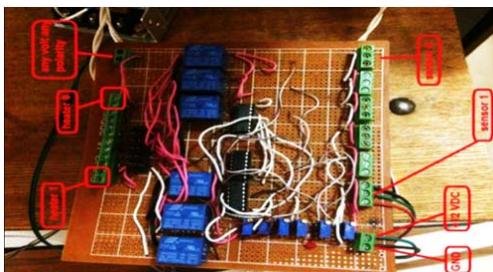

Fig. 9 Control board

I. Computer and Data Acquisition System

Fig. 10 shows the computer and the data acquisition system with analogue to digital converter. Sensors' readout will be converted to digital by analogue to digital converter device and by data interface which is connected with the computer; the changes of temperature will be recorded.

J. Infrared lamp

The infrared lamp as shown in Fig. 11 is used to simulate the heat fluxes from the sun and the earth. The intensity of the heat fluxes, in reality, depends on the distance between the sun and the SC but in our case, it will be simulated by using a voltage regulator which controls the power of the infrared

lamp according to the voltage value.



Fig. 10 Computer and data acquisition

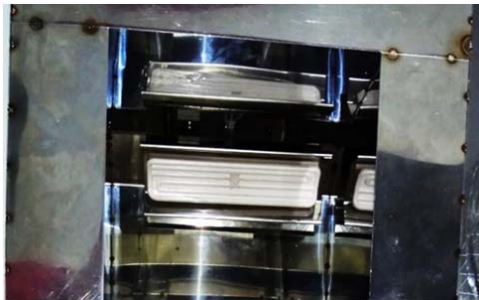

Fig. 11 Infrared lamp

Infrared lamp specifications:

- Ceramic heat lamp
- Electrical power = up to 1000 watt
- Input volt = 120 volt
- Connected with space-qualified cables

K. Mirror Box

To modify the vacuum chamber thermally to test a thermal model, Fig. 12, it was important to contain the heat fluxes around the model and ensure the uniform distribution of heat fluxes around the model. From this point, it was required a mirror box with the following specifications.

- Stainless-steel box with a very high reflective surface and low thermal conductivity.
- Cuboid with one open side to allow the model to be inserted inside it. As well as, it allow the equipment panel to face the cold plate.



Fig. 12 Mirror box

L. Voltage Regulator

It is used to supply the infrared lamp as shown in Fig. 13 by the variable voltage to simulate the variable intensity of the solar fluxes according to a specific cyclogram and algorithm.



Fig. 13 Voltage regulator

M. Cooling System for the MVC

It is a cooling system which is used to assure the cooling temperature for simulating the space conditions. The cooling and heating will be done using a special oil as a working fluid. It controls minimum and maximum temperatures for the cooling plates (from $-60\text{ }^{\circ}\text{C}$ to $+60\text{ }^{\circ}\text{C}$).



Fig. 14 Cooling system for the MVC

N. Cooling and Heating Plates

- The oil is used as a working fluid and circulated using a special pump.
- The oil is delivered to the vertical and horizontal plates at the same time with the same temperature.
- The cold plates represent the cold space inside the vacuum chamber.
- The hot plate represents the albedo.

O. MVC Interface

It is a hermetic gate which is used to connect all the technological cables from one side. As well as, it connects the

sensors, electrical heaters, and lamp cables from the other side. It consists of 10 electrical channels each one has 36 connections to be connected with sensors, lamb cables.

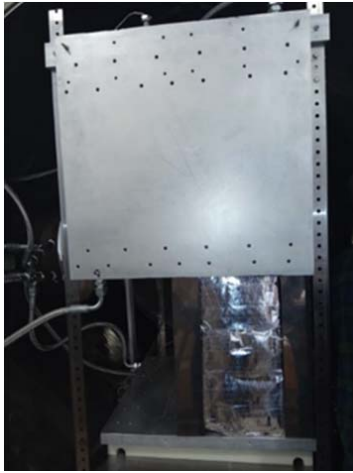

Fig. 15 Cooling and heating plates

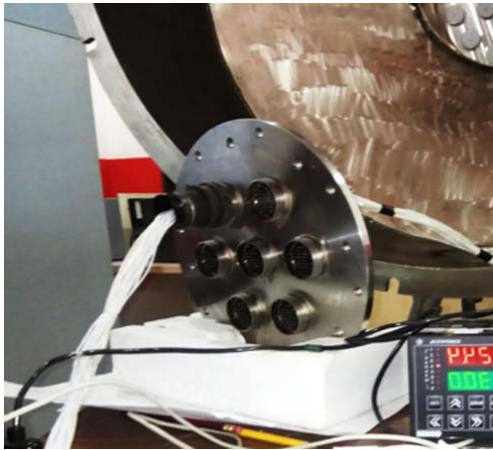

Fig. 16 MVC interface

P. Vacuum Chamber

A MVC can test a TCS. The pressure inside it is stable after the evacuation process due to the good sealing and the vacuum pumps. The vacuum pumps operate automatically if the pressure increases inside the VC to keep the required value the same during all test procedures.



Fig. 17 Vacuum chamber

TABLE VII
ELECTRICAL CHAMBER SPECIFICATIONS

Parameter	Value
Pump Type	2 Diffusion Pumps
Volume	12.4 m ³
Ultimate Pressure	1 × 10 ⁻⁶ Torr
Evacuation Time	3 h
Dimensions	Length 2550 mm Diameter 1550 mm

Q. Vacuum Pumps

Two oil rotary high Vacuum pumps Model W2V60 are used to reach the pressure 1 × 10⁻⁶ Torr in approximately 3.5 hours one is used for rapid evacuation and second is used for fine-tuning evacuation.



Fig. 18 Rotary high vacuum pumps Model W2V60

TABLE VIII
VACUUM PUMP STATISTICS SPECIFICATIONS

Displacement (50Hz)	800 L/min
Ultimate Vacuum	5 × 10 ⁻³ Torr
Oil Capacity	3 litres
Motor 50/60Hz	2000 W
Inlet connection	KF40
Outlet connection	KF40
Weight	70 Kg

R. Thermal Control Model Description

The thermal control model is mounted inside the mirror steel envelope and the infrared lamp is fixed and connected electrically with the voltage regulator. Electrical heaters and sensors are connected with the control board. Fig. 19 shows the thermal control model inside the mirror steel envelops before fixed inside the MVC.

III. PREPARATION PROCEDURES

A. Adjusting the Cooling Plates inside the MVC

The purpose of the cooling plates which is faced the solar reflector is to enhance the heat transfer from the thermal model to the external environment. The minimum temperatures of the cooling plates are -60 °C. The material of the cooling plates is aluminium. The working fluid is a cooling oil.

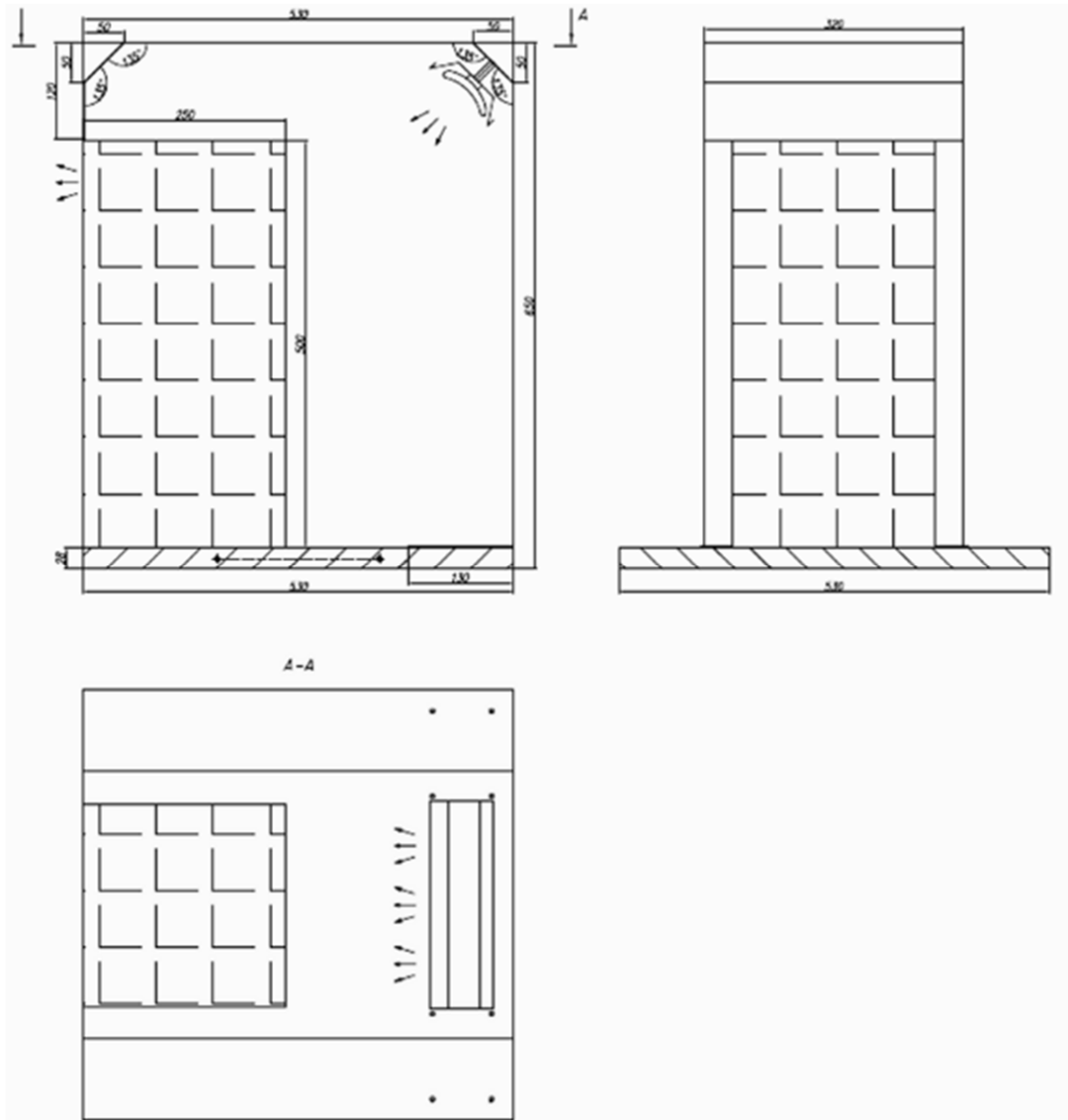

Fig. 19 SC mockup scheme

1. Fig. 20 shows the fixation of the cooling plates inside the MVC. One of the cooling plates is under the thermal model and the second faces the solar reflectors. The cooling plate faces the solar reflector far 7 cm distance from the solar reflector. The second cooling plates are mounted under the thermal model to simulate the shadow from one side of the thermal model. The horizontal cooling plates are directly contacted with the bottom panel of the thermal model.
2. Fixing the infrared lamp as shown in Fig. 21 inside the mirror box and allow the technological cables of the infrared lamp to be connected through the MVC hermetic gate with the voltage regulator.
3. Mounting the mirror steel box inside the MVC as shown in Fig. 22 and mounting the model inside the mirror box with equal distance between the mirror box and the model side panels, to assure the uniform heat fluxes distribution around the model.
4. Connecting the electrical heaters as shown in Fig. 23 and sensors cables through the mirror box first and through the MVC hermetic gate second with the electric control board.
5. Connecting the power transformer with the electric board to grantee the 24 V to be supplied to the electrical board from the main power supply.
6. Connecting the voltage regulator to the power supply.
7. Connecting the cooling system with the two cold plates and adjusting the cooling oil temperature ranges to simulate the cold space.



Fig. 20 Fixation of the cooling plate

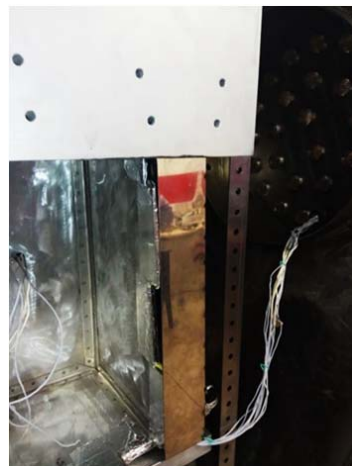

Fig. 23 Connection of electrical cables



Fig. 21 Fixing infrared lamp



Fig. 22 Mounting mirror steel box inside the MVC

B. Closing the Hermetic Gate and the MVC Gate to Start the Evacuation Process

The hermetic gate which connects the model cables and sensors, electrical heaters and infrared lamp with the technological cables of the controlling equipment has to be sealed and closed carefully to avoid the leakage and instability of the MVC pressure.

C. Evacuate the MVC to the Pressure 10⁻⁷ bar

- 1- The first process of the evacuation is outgassing the model parts and all the equipment inside the MVC.
- 2- After, the pressure will decrease until the required value using the vacuum pumps.
- 3- The evacuation process needs more than 6 hours to evacuate the MVC and to stabilize the pressure inside the MVC.
- 4- After the execution of the evacuation process, the testing procedures begin for the model.

IV. TESTING PLANS



Fig. 24 Adjust the cooling plates and refrigerator temperature

8. Adjusting the distance between the solar reflectors and the vertical cold plate to not exceed to 10 cm to assure the cooling assist of the solar reflectors.
9. Connecting the electrical sensors with the data acquisition system and to the readout the program on the computer to read out the temperatures of the sensors instantaneously.

1. Adjust the refrigerator controller at -40°C to simulate the cold space conditions as shown in Figs. 24 and 25.
2. Connect the model sensors and heaters cables with TVC interface connectors as shown in Fig. 26.
3. Connect the TVC connectors with the technological cables outside the TVC as shown in Fig. 27.

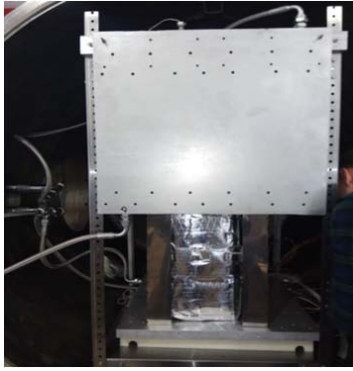

Fig. 25 Mounting the model inside the MVC

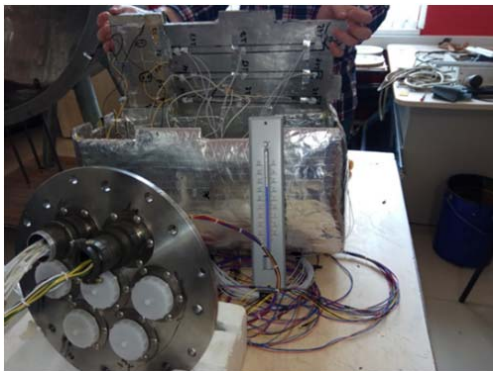

Fig. 26 Final check for cables outside MVC



Fig. 27 Connect the technological cables with the control board and infrared regulator device

4. Connect the computer with a data acquisition system and onboard control unit as shown in Fig. 28.
5. Connect the refrigerator cable to the cold plate then adjust the cooling temperature as shown in Fig. 29.
6. Evacuate the MVC using the evacuation pumps till the pressure 10-5 bar as shown in Fig. 30.

A. Experiment Procedures

- The experiment will verify the efficiency of the heat pipe as a part of the SC thermal control subsystem.
- The main task of the heat pipe is to distribute the temperature over the equipment panel uniformly.



Fig. 28 Connection of the computer with a data acquisition system and onboard control unit



Fig. 29 Connect the refrigerator cables to the cold plates



Fig. 30 Close the TVC and prepare to evacuate it

- The model is totally covered with MLI except for the solar reflector area which allows the internal heat dissipation from the equipment to exit outside the model.
- The experiments are divided into four cases:

Case 1:

- The equipment is in off mode (no heat dissipation) and the cold plate panel is operated at temperature -35°C .
- The cold plate operates for 12.5 min.
- The infrared lamp which simulates the sun solar fluxes is off (the SC in the shadow far from the sun).
- This case simulates the surviving mode of the SC which all the equipment is in non-operating mode and the SC is in the shadow. The temperature of the SC becomes colder but the MLI has to keep the SC surviving with temperature not lower than -10°C .

Case 2:

- The equipment is in operating mode for 30 min (there is heat transfer interaction between the equipment and the equipment panel).
- The infrared lamp is off.
- The cold plate is working at -40°C (facing the deep space from the bottom direction of the panel).
- This case simulates the operating mode of the SC equipment. The satellite is far from the sun, which causes

the MLI surface temperature to decrease. Due to the MLI the equipment temperature did not affect.

Case 3:

- The equipment is in non-operating mode.
- The infrared lamp is operating with different power for 30 min (the increasing the power of the infrared lamp the shorter distance to the sun).
- The cold plate is still working to simulate the opposite side panel from the sun.
- In this case, SC equipment is in non-operating conditions and the SC is pointed to the sun to charge from the solar fluxes. The equipment is in non-operating mode. The MLI prevents the heat dissipation of the SC internal equipment to exit through the SC panel so the SC internal temperature will increase.
- Because the accumulation of the heat dissipation from the

SC internal equipment, there will be a great need to a one-way direction valve.

- The solar reflector is the one-way valve which will allow to a certain amount of the heat energy to exit outside the SC. The amount of heat dissipation which exits outside the SC depends on the area of the SR (solar reflector). The greater the area of the SR, the greater the amount of heat dissipation that can be exited to space from the satellite.

Case 4:

- The equipment is in operating mode 30 min.
- The inferred lamp is in operating mode with different power according to the distance far from the sun.
- The cold plat is operating at -35 °C.
- In this case, the SC equipment operates when the SC is closer from the sun.

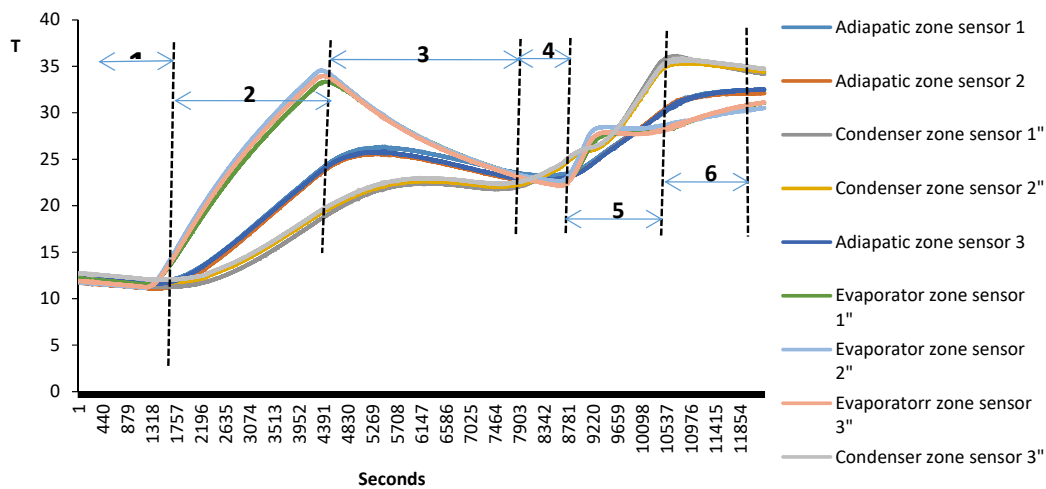

Fig. 31 Testing algorithm

As shown in Fig. 31 the testing cycle is divided into 6 zones as follows

- Zone 1: The equipment is in non-operating mode. The SC is far from the sun solar fluxes. The cold plate is working at -30 °C. The MLI prevents the internal equipment to be cold.
- Zone 2: The equipment is in operating mode. The SC is far from the solar fluxes and the farther distance from the sun means the decreasing of the infrared lamp power. The cold plates are operating at -30 °C. The MLI prevents the heat dissipation from the equipment to exit from the SC internal environment except for the heat exit from the solar reflector window.
- Zone 3: The equipment is in non-operating mode. The SC is closer from the sun the infrared operates at different power according to the position of SC (far or close from the sun). The insulation prevents the under cooling of the equipment.
- Zone 4: The HP distributes the temperature uniformly over the panel. Due to the HP thermal inertia, the HP condenser and evaporator take time to be balanced and

have the same temperature.

- Zone 5: The equipment is in operating mode. The SC is far from the solar fluxes (the infrared lamp is off).
- Zone 6: In this zone the infrared lamp and satellite equipment are switched off. That means no heat fluxes inside or outside the satellite.

V. CONCLUSIONS

- Using heat pipes decreases the electrical energy consumed by electrical heaters and decreases the power budget of SC.
- Using heat pipes improves the temperature distribution over the equipment panel and avoids the formation of hot spots between the high and low-temperature equipment over the panel surface
- A modification of the Russian vacuum chamber has been done to transform it into a TVC to can test the mockup thermally. The modification has been reviewed and tested from the Russian side experts then approved to be executed.
- Complete design and manufacture of the thermal control

subsystem mockup has been done using commercial materials because of the difficulty of having space standard material at the Middle East researches.

- The thermal mockup subsystem has been tested inside the MVC to prove the capability of using the Thermal Desktop program.
- The heat pipe distributes the temperature almost uniformly over the panel. The temperature difference between the evaporator and condenser is 15 °C in the hot case. The MLI succeeds to insulate the SC body and the calculated SR area allow the accumulated heat energy to be out the SC and preventing the external heat energy to get inside the model.

REFERENCES

- [1] Chul Hwan, Yang, Major, Rokaf, Thermal analysis of heat power radiator with rectangular groove wick structure, Air Force Institute of Technology, 1990.
- [2] Valeri V, Vlassov, Fabiano L. de Sousa and Walter K. Takahashi, investigation of optimal mass characteristics for a heat pipe radiator assembly for space application, 2006.
- [3] Cihat Arslanturk, Optimum design of space radiators with temperature dependent thermal conductivity, 2006.
- [4] M. Ameli, B. Agnewa, P.S. Leung a, B. Nga, C.J. Sutcliffe b, J. Singh b, R. McGlen c, A novel method for manufacturing sintered aluminum heat pipes, 2013.
- [5] Hui-kyung Kim, Seongim Choi, Seung-O Park, Kyun Ho Lee c Node-based spacecraft radiator design optimization, 2015.
- [6] Y. Wang, K. Vafai, An experimental investigation of the thermal performance of an asymmetrical at plate heat pipe, 2000.