

Stress Analysis of Spider Gear Using Structural Steel on ANSYS

Roman Kalvin, Anam Nadeem, Shahab Khushnood

Abstract—Differential is an integral part of four wheeled vehicle, and its main function is to transmit power from drive shaft to wheels. Differential assembly allows both rear wheels to turn at different speed along curved paths. It consists of four gears which are assembled together namely pinion, ring, spider and bevel gears. This research focused on the spider gear and its static structural analysis using ANSYS. The main aim was to evaluate the distribution of stresses on the teeth of the spider gear. This study also analyzed total deformation that may occur during its working along with bevel gear that is meshed with spider gear. Structural steel was chosen for spider gear in this research. Modeling and assembling were done on SolidWorks for both spider and bevel gear. They were assembled exactly same as in a differential assembly. This assembly was then imported to ANSYS. After observing results that maximum amount of stress and deformation was produced in the spider gear, it was concluded that structural steel material for spider gear possesses greater amount of strength to bear maximum stress.

Keywords—Differential, spider gear, ANSYS, structural steel.

I. INTRODUCTION

DIFFERENTIAL assembly is the main part of a vehicle power transmission system as it allows the vehicle to take turn along curved paths by changing the speeds of both the rear wheels. This function of different speed of the wheels is performed by the spider gear only which further transfers it to wheels through bevel gears. For surfaces where slipping occurs, spider gear can get damaged due to excessive friction between the bevel and spider gear. For such surfaces, other types of differentials are used such as limited slip differential. The material of the piston is chosen on the bases of its mechanical properties and is mostly used in gear fabrication. Gears were designed in SolidWorks, and analysis was carried out in ANSYS to determine the amount of stress and total deformation produced for the selected material.

A vehicle's wheels turn at various velocities, mostly when turning corners. The differential is intended to drive a couple of wheels with measure up to torque while enabling them to pivot at various velocities. In vehicles without a differential, e.g. karts, both driving wheels are compelled to turn at a similar speed, as a rule on a typical pivot driven by a basic chain drive instrument. While cornering, the inward wheel

requirements to movement a shorter separation than the external wheel, so with no differential, the outcome is the internal wheel turning or potentially the external wheel dragging, and this outcome in troublesome and unusual taking care which harms to tires and stress on the whole drive prepare.

Keller et al. [1] investigated the analysis of structure, operating principle, main mathematical relation of the self-blocking screw-ball differential gear operation for improving dynamic parameters in different modes of the vehicle motion. He was concluded that different geometrical parameters can be used for establishing necessary blocking factor and obtain optimal parameters for differential gear operation of vehicles under different road conditions. Keller et al. [2] focused on the nonlinear dynamic model of 4*4 vehicle with screw ball differential. Limited slip differentials were implemented to improve safety and vehicle patency. The results conclude that relative error of imitating model does not exceed 15%. Zhou et al. [3] focused on establishment of analytical solutions to evaluate bending and contact strength for spiral bevel gears considering friction on the tooth surface, which are verified through ISO gear standards. Results show that, as friction coefficient reaches 0.20, analytical solution bending stress is 14.67% which is larger than calculated according to ISO 10300-1-2001 gear standard. Jinzhan et al. [4] investigated to design and implement a seventh order function of transmission error in order to reduce the noise and vibration of gear drive and made improvements in loaded distribution of tooth. Results show that, while contact stresses remains equivalent, bending stresses of seventh order tooth are less as compared to parabolic one. Paulins et al. [5] improved the design of gear blanks with optimized tooth tips. Studies have concluded that a spiral bevel pinion/gear pair created with a rectangle can be optimized having constant tooth height and common pitch one apex. Hongxing et al. [6] discussed how to reduce the stress concentration, surface stresses, wear and tear and all the other factors that cause the failure of thrust washer. This is done by mating the different pairs of spider gear and thrust washer. The result shows more the radius of spider gear lesser will be the factors that cause failure. Bayrakceken et al. [7] investigated failure analysis of differential pinion shaft. Results show that fracture occurs at high stress region due to fatigue having combined bending, torsion, and axial stresses. The fracture's crack is at material defect region at critical location. Fracture occurs in ductile manner. Sekercioglu et al. [8] studied the fracture of spiral bevel gear in truck differential, and the results show that oil film thickness is not enough because of high contact pressure and lubrication

Roman Kalvin is with Wah Engineering College, Wah Cantt, Pakistan (corresponding author, phone: +92-345-5979377; e-mail: romankalvin@wecu.edu.pk).

AnamNadeem, is with Inha University South Korea. She is on leave from Wah Engineering College, Wah Cantt, Pakistan (e-mail: anamnadeem139@gmail.com).

ShahabKhushnood is with the Mechanical Engineering Department, University of Engineering and Technology Taxila, Pakistan (e-mail: Shahab.khushnood@uettaxila.edu.pk).

becomes difficult which causes pitting failure. Pavan et al. [9] focused on metallurgical investigation takes place at failed pinion shaft in order to study cause for failure. It was concluded that cause of failure was because of overloading irrespective of keyway, and its corners were manufactured according to design specifications. Forstinge et al. [10] developed the derivation of dynamic models for bevel gear and limited slip differentials. It was concluded that for differential gear, simulation strategy based on force balancing with two coulomb torques affecting both variables. Finally, comparison was made between simulation results and measured data. Kostrzewski et al. [11] investigated the improvement of interaction between rail vehicle's wheels and rail on tight radii curves by the use of differential gears and reduce wear of tread profiles and flanges for which a numerical study was carried out and the dynamic behavior results were compared with conventional one. The results show that conditions of outer wheel which is additionally loaded by vertical component of inertial force are improved as compared to inner wheel. Khan and Verma [12] investigated the current gear box should be replaced by a 'central differential' that consist of two side gears with different diameters placed on both sides of hub. Gear on back side operates differential of axle located on its side and the front one controls axle of its own side, modified central differential analysis was done on ANSYS software. Veeranjanyulu and Haribabu [13] studied to reduce the weight of differential gears, if gears materials (cast iron, cast steel) were replaced by aluminium. Stress as well as displacement was analyzed by keeping reduced weight in consideration in gear box providing high speed. Modeling along with assembly was performed in SolidWorks. Patil et al. [14] examined the stress analysis of differential gear box casing of pickup van vehicle, and complete finite element analysis of differential casing has been done.

II. METHODOLOGY

The spider gear assembly was designed using SolidWorks. 3D model of the assembly was imported into the ANSYS for processing which consists of meshing of the assembly followed by material selection and boundary conditions. Then, the solution was performed using ANSYS, and the results were obtained in the report regarding the stress concentration and deformation produced.

Material specifications of spider gear are shown in Table I.

Sr. No.	Parameters	Dimension
1.	Dia. of hole for shaft	100 mm
2.	Addendum circle radius	123.36 mm
3.	Pitch	29.74 mm
4.	No. of teeth	26

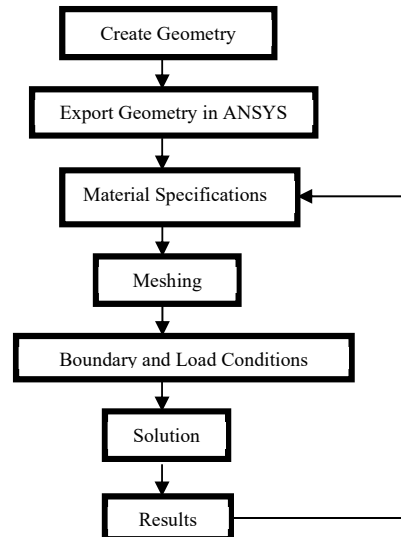

Fig. 1 Methodology

III. MODELING

The 2D drawing of spider gear as well as the bevel gear is given in Fig. 2 according to which a 3D model as well as assembly is built in SolidWorks.

3D model of spider gear and bevel gear is generated for the stress analysis.

Material specifications for structural steel are shown in Table II.

For carrying out the analysis, first of all, mesh is generated for the assembly which divides it into very small, finite number of elements.

After the meshing, this assembly is used to carry out static structural analysis by applying a torque of 5000 N.mm to obtain the results of the stress generated on the spider gear as well as the total deformation produced.

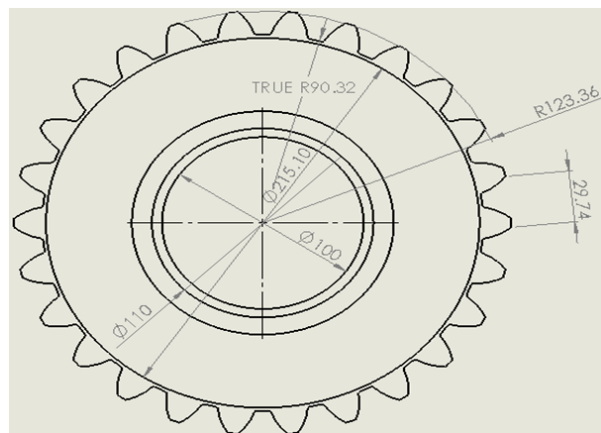

Fig. 2 2D drawing front view of spider gear

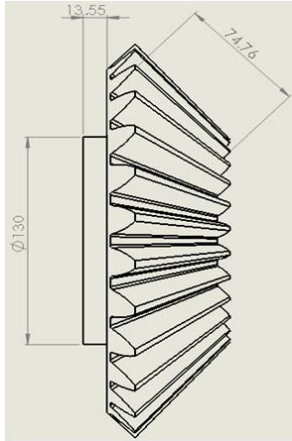

Fig. 3 2D drawing side view of spider gear

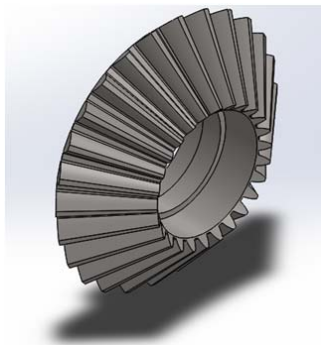

Fig. 4 3D model of spider gear

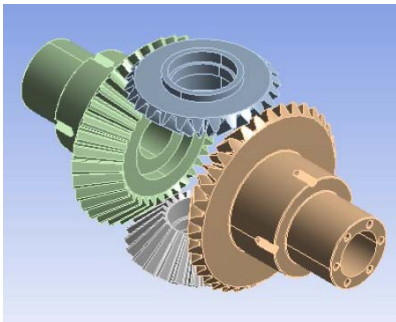

Fig. 5 Assembly of spider gear with bevel gear

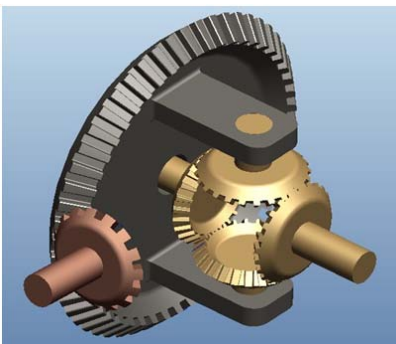

Fig. 6 Complete model of differential assembly

TABLE II
MATERIAL SPECIFICATIONS OF STRUCTURAL STEEL

Property	Value	Units
Structural Steel Constraints		
Density	7.85e-006	kg/mm ³
Co-efficient of thermal expansion	1.2e-005	C ⁻¹
Specific Heat	4.34e+005	mJkg ⁻¹ C ⁻¹
Thermal Conductivity	6.05e-002	Wmm ⁻¹ C ⁻¹
Ultimate tensile strength	460	MPa
Ultimate Strength	0	MPa
Yield Strength	250	MPa
Property Value Units		
Structural Steel Parameters		
Strength Coefficient	920	MPa
Ductility Exponent	-0.47	
Cyclic strain Hardening Coefficient	0.2	
Strength Exponent	-0.106	
Poisson's ratio	0.3	
Bulk Modulus	1.67e+005	MPa
Shear Modulus	76923	MPa
Young's Modulus	2e+005	MPa
Cyclic Strength Coefficient	1000	MPa

IV. RESULTS

Result generated by the ANSYS after the analysis of the spider gear assembly is shown in Fig. 7.

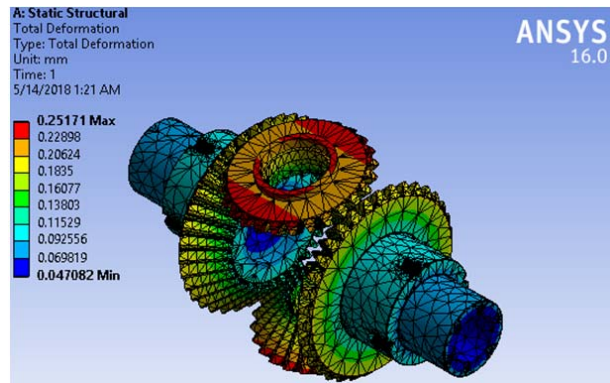

Fig. 7 Total deformation

Results show that the spider gear bears the maximum stress on the teeth's which are not meshed with bevel gear teeth's and it is equal to 43.34 MPa. Deformation produced as a result of this stress is maximum in the spider gear at the same position which is equal to 0.25 mm for structural steel.

V.CONCLUSIONS

From the above analysis of spider gear assembly, it can be concluded that the maximum stress generated as well as the maximum deformation is produced in the spider gear whereas the bevel gear is not affected that much as both the gears have the same material. So, it can be concluded that the material for spider gear must possess greater yield strength than that for bevel gear to bear the stress that is generated on the teeth of spider gear.

REFERENCES

- [1] Keller, A. V., A. A. Shelepov, and D. I. Istomin. "Study on Screw-ball Differential Gear Operating Process." *Procedia engineering* 129 (2015): pp. 535-541.
- [2] Keller, A. V., A. A. Shelepov, and D. I. Istomin. "Estimation of Screw-ball Differential on Vehicle Dynamics." *Procedia Engineering* 150 (2016): pp.1131-1136.
- [3] Zhou, Changjiang, et al. "Analytical solution to bending and contact strength of spiral bevel gears in consideration of friction." *International Journal of Mechanical Sciences* 128 (2017): pp. 475-485.
- [4] Su, Jinzhan, Zongde Fang, and Xiangwei Cai. "Design and analysis of spiral bevel gears with seventh-order function of transmission error." *Chinese Journal of Aeronautics* 26.5 (2013): pp. 1310-1316.
- [5] Paulins, Karlis, Arturs Irbe, and Toms Torims. "Spiral Bevel Gears with Optimised Tooth-End Geometry." *Procedia Engineering* 69 (2014): pp. 383-392.
- [6] Wu, Hongxing, et al. "Modification of spider gear back to uniform the stress and improve the anti-wear performance of a real thrust washer." *Engineering Failure Analysis* 60 (2016): pp. 107-116.
- [7] Bayrakceken, H. "Failure analysis of an automobile differential pinion shaft." *Engineering Failure Analysis* 13.8 (2006): pp. 1422-1428.
- [8] Sekercioglu, Tezcan, and Volkan Kovan. "Pitting failure of truck spiral bevel gear." *Engineering Failure Analysis* 14.4 (2007): pp. 614-619.
- [9] Pavan, A. H. V., et al. "Root cause analysis of bowl-mill pinion shaft failures." *Case Studies in Engineering Failure Analysis* 1.2 (2013): pp. 103-109.
- [10] Forstinger, Martin, Robert Bauer, and Anton Hofer. Modelling and Simulation of Passive Limited-slip Differentials." *IFAC-Papers On Line* 48.1 (2015): pp. 502-507.
- [11] Kostrzewski, Mariusz, and Rafał Melnik. "Numerical dynamics study of a rail vehicle with differential gears." *Procedia engineering* 192 (2017): pp. 439-444.
- [12] Khan, Amir, and Sankalp Verma. "Design and Analysis of Automobile Central Differential Having Two Different Side Gear." *International Journal of Scientific Research & Development* (2015), Vol 3, Issue 4.
- [13] Veeranjanyulu, C., and U. HariBabu. "Design And Structural Analysis of Differential Gear Box at Different Loads." *International Journal of Advanced Engineering Research and Studies* 1 (2012): 65-69.
- [14] Patil, Shrenik M., and S. M. Pise. "Modal and Stress Analysis of Differential Gearbox Casing with Optimization." *International Journal of Engineering Research and Applications* 3 (2013): 188-193.