

Quantitative Changes in Biofilms of a Seawater Tubular Heat Exchanger Subjected to Electromagnetic Fields Treatment

Sergio Garcia, Alfredo Trueba, Luis M. Vega, Ernesto Madariaga

Abstract—Biofilms adhesion is one of the more important cost of industries plants on wide world, which use to water for cooling heat exchangers or are in contact with water. This study evaluated the effect of Electromagnetic Fields on biofilms in tubular heat exchangers using seawater cooling. The results showed an up to 40% reduction of the biofilm thickness compared to the untreated control tubes. The presence of organic matter was reduced by 75%, the inorganic mater was reduced by 87%, and 53% of the dissolved solids were eliminated. The biofilm thermal conductivity in the treated tube was reduced by 53% as compared to the control tube. The hardness in the effluent during the experimental period was decreased by 18% in the treated tubes compared with control tubes. Our results show that the electromagnetic fields treatment has a great potential in the process of removing biofilms in heat exchanger.

Keywords—Biofilm, heat exchanger, electromagnetic fields, seawater.

I. INTRODUCTION

SEAWATER is an aqueous solution having large concentrations of ions and a high biological activity. The formation of organic and inorganic deposits that depend on biotic and abiotic factors inherent to the system is unavoidable when seawater is used in industrial heat exchange processes [1]. The formation of these deposits on surfaces used for heat exchangers has well-known consequences on heat transfer efficiency [2], [3]. Seawater in a cooling systems contains excessive mineral ions especially calcium and magnesium ions as the conduction and convention of seawater is the primary mode of heat transfer in heat exchanger, leaving those mineral ions behind. In particular, calcium ions reacting with carbonate ions in water form layers of calcium carbonate (CaCO_3) deposit on heat transfer surfaces, decreasing the efficiency of heat exchangers because of the insulating effect of the deposits. Furthermore, the formed deposits reduce the flow area, thus requiring more pumping power to achieve the flowrate of water corresponding to the clean state.

Previous research conducted by other authors [4]–[7] did not report concluding results on the use of electromagnetic fields (EMFs) for scale control in industrial, tap water and natural water. Other researchers [8]–[10] have indicated that the EMFs effect is dependent on the nature and condition of water, such as alkalinity, pH, conductivity and hardness,

Sergio Garcia is member of Biofouling Research Group (<https://biofouling.unican.es/>), University of Cantabria, 39004 Spain (corresponding author, e-mail: sergio.garcia@unican.es).

Alfredo Trueba, Luis M. Vega and Ernesto Madariaga are members of Biofouling Research Group (<https://biofouling.unican.es/>), University of Cantabria, 39004 Spain.

most of them have not controlled the water properties in their studies. EMFs are physical tensor fields produced by electrically charged elements that affect particles with an electric charge, thus having the capacity to precipitate mineral ions dissolved in the water as crystals of mineral salts, including CaCO_3 . This precipitation and not adhesion to the surfaces affect the intermolecular interactions among extracellular polymers, thereby weakening the biofilm matrix and reducing its adhesion capacity [11], hence preventing the formation/adherence of the precipitates onto the walls of the heat transfer surfaces.

This study evaluated the antifouling (AF) action of a continuous physical treatment process with EMFs applied to the seawater used as the refrigerant fluid in a heat exchanger. The aim was to minimise the biofilm adhesion on the internal tube surface and study the effect of EMFs in composition and structures of the biofilms produced. The scientific relevance of this research in AF is very highlight because it involves a new environment friendly technology against biofouling to improve efficiency and productivity in sea cooling system.

II. EXPERIMENTAL

A. Pilot Plant

The experimental plant (Fig. 1) consisted of a single step counter-flow tubular heat exchanger manufactured according to the Tubular Exchanger Manufacturing Association (TEMA) standards. The outer casing had an external diameter of 240 mm (20 mm thick) and was constructed from AISI 304 SS. The tube bundle was formed by four independent tubes 3,163 mm long (10.2 mm interior diameter and 2.5 mm thick) linearly arranged at 90 and made from AISI 316Ti (N6 class surface roughness). The coolant seawater was taken from Santander Bay in northern Spain (4328N and 348W). After filtering and decanting, circulation pumps (Grundfoss CHI 4-50 AWG) pumped the seawater, at 1.9 bar in a turbulent regime ($\text{Re} = 9,400$), toward the tube bundles of the heat exchangers. The flow-rate supplied to each tube was kept constant at 1 m s^{-1} by means of a positive displacement flow meter. The average difference between the heat exchanger inlet and outlet temperatures was $5.1 \text{ }^\circ\text{C}$.

B. EMF Device

The EMFs-generating unit comprised two coils in series (separated by 100 mm) wrapped in a tube having a length of 804 mm and water path diameter of 50 mm. This unit

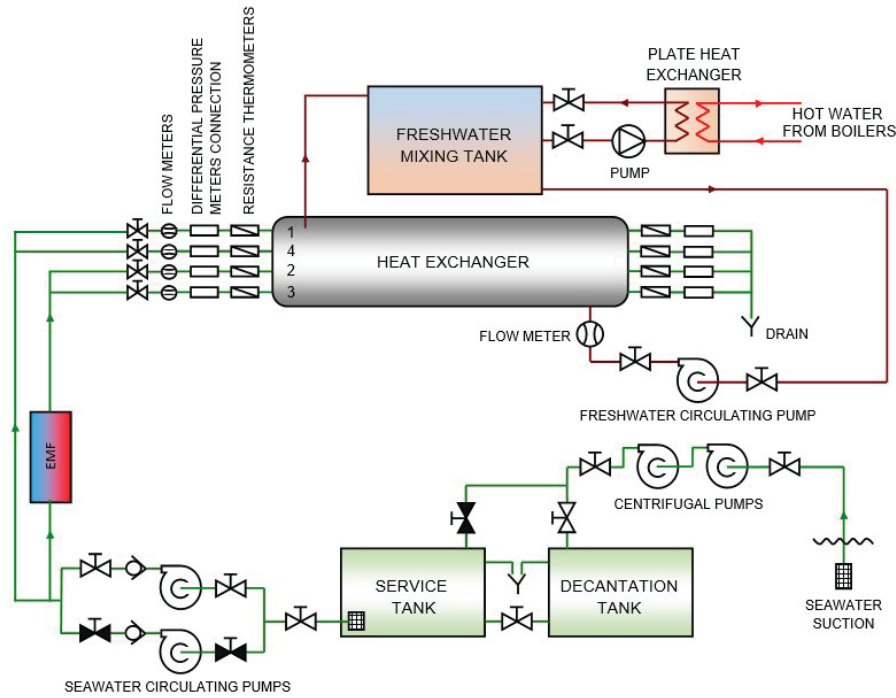

Fig. 1 Schematic arrangement of the experimental plant

generated EMFs with a strength of 15 mT and a 1 kHz (12 V) frequency under the control of the control unit. Therefore, the EMF unit produced a pulsing current to create time-varying EMFs inside the tube that precipitated calcium (Ca^{2+}) and carbonate (CO_3^{2-}) ions as CaCO_3 .

C. Quantitative Determination of Biofilm

The quantitative evolution of biofouling adhered to the internal surface tubes of tubes walls in the heat exchanger was followed using direct measurements (thickness and composition of the biofilm), which depended on the solid matter deposited on the internal surface tubes with known weights and dimensions. The biofouling thickness was calculated with (1) [12]:

$$\varepsilon = \frac{\Delta m}{2 \cdot \pi \cdot r \cdot l \cdot \rho} \quad (1)$$

where ε is the biofilm thickness (m), Δm is the biofilm mass (g) or the difference between the weight of the wet biofilm and the initial unladen test tube weight, r is the test tube internal radius (cm), l is the test tube length (cm) and ρ is the biofilm density (1.025 g cm^3).

Once the total mass of biofouling was known, the water present in the composition of the biofouling film was determined as the difference between the weight of the wet biofouling and the biofouling dried at 105°C for 4 h. The amount of organic matter was determined as the difference between the weight of the dry biofouling and the biofouling incinerated at 550°C for 12 h. The rest was inorganic matter. The influence of the EMF in the tubes of a heat exchanger cooled by seawater on the development and composition of

biofilms and on the efficiency of the heat transfer process was evaluated experimentally.

The heat transfer resistance (ΔR_f [$\text{m}^2 \text{ K}^{-1} \text{ W}^{-1}$]) was calculated using (2) [14].

$$R_f = \frac{A_t}{Q \rho C_p \ln \left(\frac{T_{shell} - T_{inC/W}}{T_{shell} - T_{outC/W}} \right)} \quad (2)$$

where A_t is the total surface covered by biofilm deposits in the tube (m^2), Q is the cooling water flow rate ($\text{m}^3 \text{ s}^{-1}$), ρ is the seawater density ($1,025 \text{ kg m}^{-3}$), C_p is the specific heat at constant pressure ($4.18 \text{ J kg}^{-1} \text{ K}^{-1}$), T_{shell} is the shell temperature (K), $T_{inC/W}$ is the cooling water inlet temperature (K) and $T_{outC/W}$ is the cooling water outlet temperature (K).

The capacity of the biofilm to conduct heat (biofilm thermal conductivity) was calculated on based on the heat transfer resistance (indirect measurement) and the thickness of the biofilm (direct measurement), in accordance with (3) [3]:

$$\lambda_{Biofilm} = \frac{\varepsilon}{\Delta R_f} \quad (3)$$

where, $\lambda_{biofilm}$ is the biofilm thermal conductivity of the biofilm ($\text{W m}^{-1} \text{ K}^{-1}$), ε is the biofilm thickness (m) and ΔR_f is the increase from the initial value of the heat transfer resistance ($\text{m}^2 \text{ K}^{-1} \text{ W}^{-1}$).

D. Analysis of Seawater

The measurements of the conductivity and concentrations of dissolved calcium (Ca^{2+}) and magnesium (Mg^{2+}) (ASTM D1126-12) in the influent and effluent were obtained to explain the mechanism of action of the EMFs and the influence on

the seawater composition. The instrument used to measure conductivity of water was supplied by Crison model MM41, which is a high precision tool to measure conductivity. Daily measurements of the total hardness (ASTM D1126-12 2012) in the effluent treated and untreated were obtained to explain the mechanism of action of the EMFs and the influence on the seawater composition. The sum concentrations of dissolved Ca^{2+} and Mg^{2+} are total hardness [13]. The standard test method for CaCO_3 content (ASTM D4373-96) was used in the determination of the calcium carbonate content of dried samples of biofilm.

E. Microscopical Biofilm Analysis

The biofilms samples were observed (with a 2 x zoom) by optical microscope (MOTIC model SMZ-168), incorporating a charge-coupled device (MOTICAM model 2300), that it allowed the capture of digital images.

F. Statistical Analysis

Documentation and statistical analysis was performed using the software IBM SPSS Statistics version 22.0 for windows (IBM, Armonk, NY, USA). After obtaining mean values and standard deviations of thickness and composition of the biofilm for each tube with different roughness, the Shapiro-Wilk showed that the data were not normally distributed. The data were compared globally using the Friedman test with a significance level of $p=0.05$.

G. Experimental Procedure

The experiment was completed in 60 days during the time of year when the biological activity was at its maximum (June to July 2013) [14]. During this time, the hydraulic conditions were kept constant for each of the four tubes in the heat exchanger. The EMF treatment was applied in tubes 2 and 3 of the heat exchanger (Fig. 1). Tubes 1 and 4 were used as untreated controls to compare the composition between treated and untreated tubes. The results are expressed as the mean value of the measurements of the two tubes constituting each experimental group.

III. RESULTS AND DISCUSSION

According with in previous experiments [2], [14], [15], these results demonstrated that the hydraulic-thermal conditions in the untreated heat exchanger favour the formation of biofilm on the internal surface of the tubes. The measurements taken in the untreated control tubes at the end of the experiment determined a biofilm thickness of 383 m. The biofilm was composed of 83% water, 13% inorganic matter and 4% organic matter (Fig. 2). The concentration of dissolved solids was 4.7 mg cm^{-2} , of which 74% was inorganic matter and 26% was organic matter. The measurements taken in the treated tubes with EMFs at the end of the experiment determined a biofilm thickness of 229 m. The biofilm was composed of 97% water, 2% inorganic matter and 1% organic matter (Fig. 2). The concentration of dissolved solids was 2.2 mg cm^{-2} , of which 73% was inorganic matter and 27%

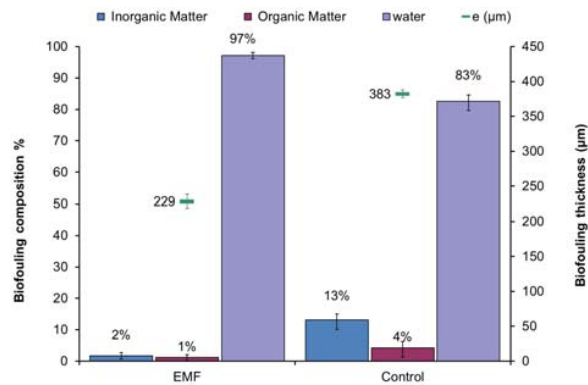

Fig. 2 Mean thickness and composition of the biofilm at the end of the experiment

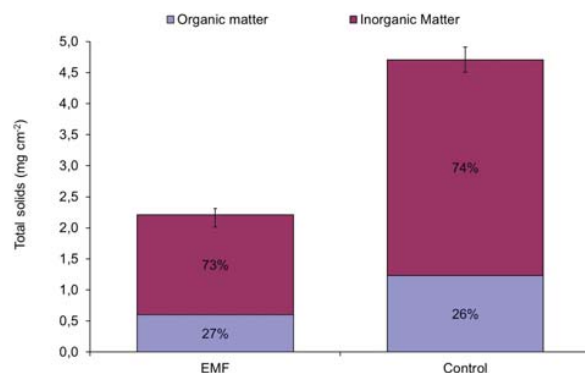

Fig. 3 Mean solids and thermal conductivity of the biofilm at the end of the experiment

was organic matter. The application of the EMFs treatment demonstrated a 40% reduction of the biofilm thickness compared to the untreated control tubes. The presence of organic matter was reduced by 75%, the inorganic matter was reduced by 87%, and 53% of the dissolved solids were eliminated (Fig. 3). The Friedman test revealed significant differences between untreated and treated samples ($p<0.05$).

Considering that around of 80% of the biofilm composition was water and the thermal conductivity of seawater was $0.6 \text{ W m}^{-1} \text{ K}^{-1}$, it can be inferred that the thermal conductivity of the biofilm and its R_f were dependent on the concentration and nature of the solids dissolved in biofilm. Therefore, the increase of solids present in the biofilm adhered to the tube translated into a 53% average decrease of the biofilm thermal conductivity in the treated sample ($2.21 \text{ W m}^{-1} \text{ K}^{-1}$) compared to the untreated sample ($4.7 \text{ W m}^{-1} \text{ K}^{-1}$).

The reduction of the dissolved solids was caused by the capacity of EMFs to precipitate mineral ions dissolved in water as mineral salt crystals, which avoid adherence to the tube surfaces [2]. In this sense, the capacity of the EMFs to precipitate ions dissolved in seawater was evidenced by the mean variation of the water conductivity before (54.9 mS cm^{-1}) and after (53.8 mS cm^{-1}) the treatment. The conductivity is directly proportional to the concentration of dissolved ions and their mobility in solution [1]. Therefore, the EMFs-induced reduction of the water conductivity is caused

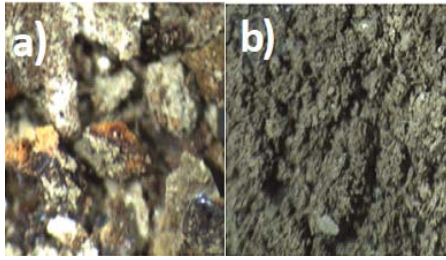

Fig. 4 Samples of Microscope images of dried biofilms prepared for observation: a) untreated and b) treated samples

by the precipitation of the dissolved ions that crystallised into particles that become suspended in the medium. In particular, the EMFs of Ca^{2+} and Mg^{2+} contributed to the understanding of the physicochemical processes that occur in the water treated with EMFs. The mean concentration of Ca^{2+} and Mg^{2+} in the seawater sample during the experimental period was 2.63 g L^{-1} , which decreased by 6% at the outlet in the control tubes and by 24% at the outlet of the EMF-treated tubes. This reduction of the ions dissolved caused a 60% reduction of CaCO_3 in the composition of the biofilm that it showed more loosely packed and non-compact structures that untreated samples (Fig. 4). The precipitation of CaCO_3 had two effects on the biofilm adhered to the interior tube surface: i) the precipitation of ions dissolved in water affected the intermolecular interactions among extracellular polymers, thereby weakening the biofilm matrix and reducing its adhesion capacity [11] and ii) the drag of CaCO_3 in turbulent mode created by the flow of refrigerant water out of the system, which has an erosive action on the biofilm [7].

IV. CONCLUSION

The EMFs treatment increased the mobility of ions dissolved in the seawater and increased the probability of collisions among them, thereby favouring their nucleation in the bulk of the seawater, hence preventing the formation/adherence of the precipitates on the insides tube walls of the heat exchanger that the natural proliferation of biofilm is changed. Furthermore, the effect of reduction in conductivity and biofilm due to EMFs indicate a formation of fine-suspended particles (CaCO_3) which are entrained in seawater flow produce an erosive action on the biofilm. Consequently, the biofilm adhering to the internal surface of the tubes was thinner and contained a lower concentration of dissolved solids. This suggests that the heat transfer resistance is lower and the efficiency of the heat transfer process is higher with the use of EMFs. The effectiveness of the EMFs increases with increasing alkalinity and hardness of the water. The use of EMFs was demonstrated to be an appropriate AF method for heat exchanger facilities that use seawater as refrigerant fluid.

REFERENCES

- [1] Trueba A, Garca S, Otero FM. *Mitigation of biofouling using electromagnetic fields in tubular heat exchangers condensers cooled by seawater*. *Biofouling* 30(1):95-103. 2014.

- [2] Cho YI, Fan C, Choi BG. *Theory of electronic anti-fouling technology to control precipitation fouling in heat exchangers*. *Int Commun Heat Mass*. 24: 757770. 1997.
- [3] Trueba A, Garca S, Otero FM, Vega LM, Madariaga E. *The effect of electromagnetic fields on biofouling in a heat exchange system using seawater*. *Biofouling*. 31(1):19-26. 2015.
- [4] Shahryari A, Pakshir M. *Influence of a modulated electromagnetic field on fouling in a double-pipe heat exchanger*. *J Mater Process Technol*. 203: 389-395. 2008.
- [5] Lipus LC, Ako B, Hamler A. *Electromagnets for high-flow water processing*. *Chem Eng Process*. 50:952-958. 2011.
- [6] Xiaokai X. *Research on the electromagnetic anti-fouling technology for heat transfer enhancement*. *Appl Therm Eng*. 28: 889-894. 2008.
- [7] Gabrielli C, Jaouhari R, Maurin G, Keddam M. *Magnetic water treatment for scale prevention*. *Water Res*. 35: 32493259. 2001.
- [8] Tai, C.Y.; Wu, Chi-Kao; Chang, Meng-Chun. *Effects of magnetic field on the crystallization of CaCO_3 using permanent magnets*. *Chemical Engineering Science*. 63: 5606-5612. 2008.
- [9] Tijing, L. D.; Kim, H. Y.; Lee, D. H.; Kima, C.S.; Choc, Y.I. *Use of an oscillating electric field to mitigate mineral fouling in a heat exchanger*. *Experimental heat transfer*. 22: 257-270. 2009.
- [10] Santomauro, G.; Baier, J.; Huang, W.; Pezold, S.; Bill, J. *Formation of calcium carbonate polymorphs induced by living microalgae*. *Journal of Biomaterials and Nanobiotechnology*. 3: 413-420. 2012.
- [11] Garcia S, Trueba A. *Influence of the Reynolds number on the thermal effectiveness of tubular heat exchanger subjected to electromagnetic field-based antifouling treatment in an open once-through seawater cooling system*. *Appl Therm Eng*. 140: 531-541. 2018.
- [12] Trueba A, Vega LM, Garca S, Otero FM, Madariaga E. *Mitigation of marine biofouling on tubes of open rack vaporizers using electromagnetic fields*. *Water Sci. Technol*. 73: 1221-1229. 2016.
- [13] Slowinski EJ, Wolsey WC, Rossi RC. *Chemical principles in the laboratory*. Brooks/Cole. 10th ed. Minnesota (MN): Cengage Learning. 28: 225230. 2012.
- [14] Garcia S, Trueba A, Vega L.M., Madariaga E. *Impact of the surface roughness of AISI 316L stainless steel on biofilm adhesion in a seawater-cooled tubular heat exchanger-condenser*. *Biofouling* 32: 19. 2016.
- [15] Lpez-Galindo C, Casanueva JF, Nebot E. 2010. *Efficacy of different antifouling treatments for seawater cooling systems*. *Biofouling*. 26: 923930. 2010.



Sergio García PhD. Marine Engineer. Mechanical Engineer. International Welding Engineer. Lecturer and Researcher. School of Maritime Engineering. Member of RDI of Biofouling Research Group. Cantabria University. Spain.