

Study on the Effect of Bolt Locking Method on the Deformation of Bipolar Plate in PEMFC

Tao Chen, ShiHua Liu, JiWei Zhang

Abstract—Assembly of the proton exchange membrane fuel cells (PEMFC) has a very important influence on its performance and efficiency. The various components of PEMFC stack are usually locked and fixed by bolts. Locking bolt will cause the deformation of the bipolar plate and the other components, which will affect directly the deformation degree of the integral parts of the PEMFC as well as the performance of PEMFC. This paper focuses on the object of three-cell stack of PEMFC. Finite element simulation is used to investigate the deformation of bipolar plate caused by quantity and layout of bolts, bolt locking pressure, and bolt locking sequence, etc. Finally, we made a conclusion that the optimal combination packaging scheme was adopted to assemble the fuel cell stack. The scheme was in use of 3.8 MPa locking pressure imposed on the fuel cell stack, type II of four locking bolts and longitudinal locking method. The scheme was obtained by comparatively analyzing the overall displacement contour of PEMFC stack, absolute displacement curve of bipolar plate along the given three paths in the Z direction and the polarization curve of fuel cell. The research results are helpful for the fuel cell stack assembly.

Keywords—Bipolar plate, deformation, finite element simulation, fuel cell, locking bolt.

I. INTRODUCTION

A fuel cell is an energy conversion device that converts the chemical energy stored in fuels and oxidants into electricity through electrochemical reactions, which can provide clean, efficient, and sustainable energy. It is considered to be one of the new energy technologies that mostly have the development and application [1], [2]. In practical application, the PEMFC products are basically composed of dozens or even hundreds of single fuel cell with the proper assembled method, so that the stack has a large power output. The stack assembly is one of the key manufacturing technologies in PEMFC, so a good packaging can both greatly improve the overall performance of the fuel cell and ensure a longer life and higher stability [3]. In order to assemble each component of stack in PEMFC together, three kinds of loading methods are usually adopted, which are point loads, line loads, and surface loads [4], and the point load is the most common way [5]. But, during the process of loading point load, the specific loading method (such as the quantity and layout of bolts, bolt locking pressure and

bolt locking sequence etc.) can cause bipolar plates to warp in different forms and degrees, and then, it can affect the deformation degree of other parts in the stack, which will influence the performance of the PEMFC. Therefore, the change of the locking bolt loading method for point load in assembly will have a significant influence on the performance of PEMFC.

The greater force during the process of point load loading will cause the components of PEMFC to elastically deformed or even damage [6], [7], but the smaller force will increase the contact impedance in the interface between the gas diffusion layer (GDL) and the bipolar plate or will cause the PEMFC leakage and other problems [8], [9]. During the process, the quantity of bolts and bolt locking sequence will have different effects on different components of PEMFC, e.g. Wen et al. [10] experimentally investigated the effects of various combinations of bolt configuration and clamping torque on the corresponding contact pressure distributions and performances of a single PEMFC and a 10-cell stack. According to analysis, the authors drew the conclusion that the performance of PEMFC is affected by the quantity of bolts, bolt locking sequence, and clamping force. In addition, in order to get the suitable clamping force, there are many other studies on it to make the PEMFC stack achieve the optimal performance [11]-[14]. The relation between clamping force, GDL compression, and mechanical properties of the gaskets used, is illustrated by using a conventional cell hardware in which bolts are used as a tightening system by Gatto et al. [11]. Yim et al. [12] show that the decrease of contact resistance by high GDL compression affects more dominantly on the stack performance than the increase of mass transport resistance in the present stack configurations. The degree of GDL compression also affected the stack stability, particularly, under the reformed gas conditions as anode fuel. In these literatures, it can be seen that the influence of parameters during the process of PEMFC stack assembly on the performance of PEMFC, and the parameters are mainly controlled by the locking bolt loading method. During the process of loading, locking bolt will first lead to deformation of the bipolar plate, which causes the deformation of the other components. Therefore, the deformation of the bipolar plate will directly affect the deformation degree of the integral part of the PEMFC as well as the performance of PEMFC. So, it is very necessary to study the deformation of the bipolar plate caused by the bolt loading method during the assembly process of the PEMFC stack.

The assembly of each component of PEMFC stack has high requirements on the parameters, the manufactured components of the PEMFC stack cannot be assembled blindly, the

Shihua Liu is with the Wuhan University of Technology, School of Mechanical and Electronic Engineering, 122 LuoShi road, Wuhan 430070, China (corresponding author, phone: +86-27-87651793; fax: +86-27-87651793; e-mail: lshtgyx@163.com).

Tao Chen is with the Wuhan University of Technology, School of Mechanical and Electronic Engineering, 122 LuoShi road, Wuhan 430070, China (phone: +86-27-87651793; fax: +86-27-87651793; e-mail: chent29@whut.edu.cn).

appropriate packaging parameters must be determined before assembling, so that the PEMFC stack will have a better overall performance. Currently, for the fuel cell stack, the general packaging process parameters are determined by the finite element simulation analysis and experimental method, but only through finite element simulation to determine the parameters during the process of packaging when the stack is more complex [15]-[18]. Through finite element simulation method, on the one hand, the subtle changes during packaging process parameters that influence the performance of PEMFC stack assembly can be detected, so that the parameters can be optimized as soon as possible, and the results of the simulation analysis can provide a reference for the actual assembly process. On the other hand, it can save the cost of determining the assembly parameters by experiment and improve the packaging efficiency. Therefore, the three-cell stack of PEMFC is taken as the research object in this paper. Finite element analysis is used to study the deformation of bipolar plates caused by the effects of quantity and layout of bolts, bolt locking pressure and bolt locking sequence etc. Different with the previous studies, this paper focuses on the deformation of the bipolar plate caused by locking bolt loading without analyzing of other components, which simplifies the process of solving the model. By controlling the degree of deformation of the bipolar plate to achieve the best state of the fuel cell assembly, it can be concluded that the optimum assemble method with a given specification of the PEMFC.

II. THE DEFORMATION OF THE BIPOLAR PLATE CAUSED BY THE EFFECTS OF QUANTITY AND LAYOUT OF LOCKING BOLTS

It can be learned from previous paper that the differences of quantity and layout of locking bolt will have influence to the PEMFC performance during packaging process of the fuel cell stack. There must be a best way of the quantity and layout of the locking bolt so that we can achieve the most uniform deformation to components of the cell stack for PEMFC stack with fixed structure. In this paper, by the example of rectangle (100×86mm) bipolar plates, the finite element simulation analysis is used to analyze and compare the overall displacement contour of cell stack and the bipolar plate, and comprehensively analyze the displacement curve along a given path which is based on the bipolar plate, then determine the quantity and layout of locking bolt when the deformation of bipolar plate is optimum. Now several representative groups of quantity and layout of locking bolts were chosen to be analyzed. As shown in Fig. 1, a quantity of locking bolts on bipolar plate are 4, 6 and 8 respectively, and each has two kinds of different layout.

III. THE DISPLACEMENT CONTOUR OF BIPOLAR PLATE WITH DIFFERENT QUANTITY AND LAYOUT OF LOCKING BOLTS

At the guarantee of the same clamping pressure, there is a finite element simulation analysis for each fuel cell stack with different quantity and layout of locking bolts in the initial state, it can obtain the overall displacement contour and the displacement contour of bipolar plate in each case. As shown in

Figs. 2-7, the deformation of the locking bolt position significantly higher than other positions and the stress of the locking bolt position is more concentrated, which shows that the layout of the locking bolt has an impact on the deformation of the bipolar plate.

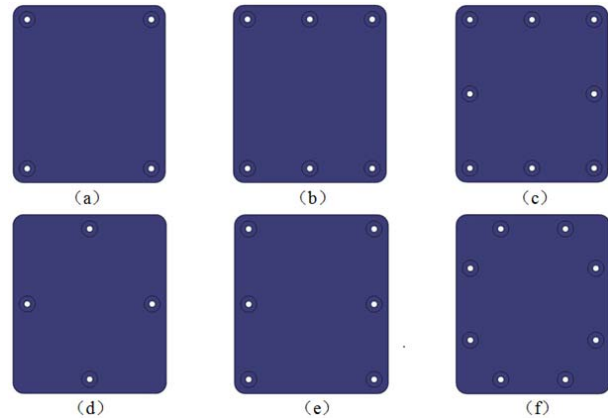

Fig. 1 The quantity and layout of locking bolts on bipolar plate of PEMFC (a) typeIof 4 bolts, (b) typeIof 6 bolts, (c) typeIof 8 bolts, (d) typeIIof 4 bolts, (e) typeIIof 6 bolts, (f) typeIIof 8 bolts

It can be drawn from Figs. 2-7 that the maximum displacement of the fuel cell stack with different quantity and layout of locking bolt is shown in Table I, as soon as the maximum displacement of the bipolar plate. From Table I, we can learn that the maximum displacement of the fuel cell stack and bipolar plate is minimal when the layout of locking bolt is type II of four locking bolts, in order to further obtain the optimal quantity and layout of the locking bolt, we will have an analysis of the displacement with bipolar plate along the given path.

TABLE I
THE MAXIMUM DISPLACEMENT OF PEMFC STACK AND BIPOLAR PLATE

Item	PEMFC stack (mm)	Bipolar plate (mm)
typeIof 4 bolts	0.15682	0.01314
type II of 4 bolts	0.07999	0.00712
typeIof 6 bolts	0.16443	0.01703
type II of 6 bolts	0.15229	0.01149
typeI of 8 bolts	0.16263	0.0129
type II of 8 bolts	0.1019	0.0084

IV. THE DISPLACEMENT OF BIPOLAR PLATE ALONG THE GIVEN PATH

In order to further analyze the deformation caused by different layout of locking bolt in PEMFC bipolar plate, three paths on the bipolar plate are defined which have a large displacement and can represent the overall deformation of the bipolar plate. The three paths are respectively named X direction (H), Y direction (V) and a diagonal direction(S), as shown in Fig. 8. ANSYS/Workbench software was used to conduct finite element simulation in the defined three paths. MATLAB software was used to analyze the simulation results and draw the curve of displacement deformation of bipolar

plate in the Z-direction of the three paths, as shown in Fig. 9.

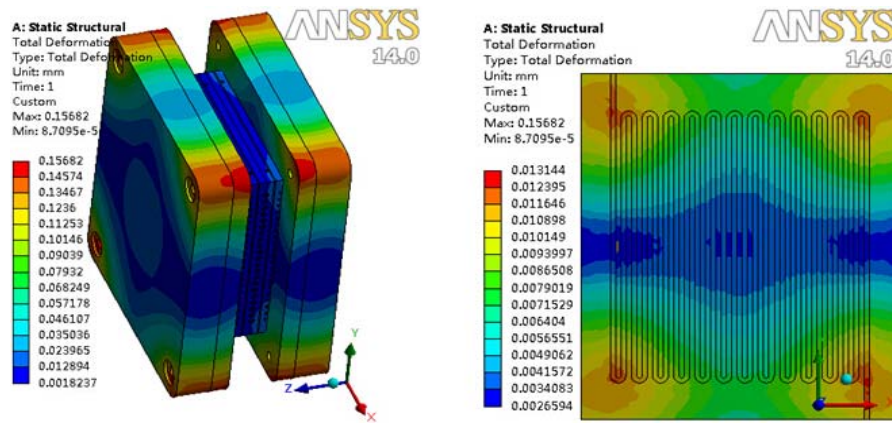

(a) The overall displacement contour

(b) The displacement contour of bipolar plate

Fig. 2 The displacement contour with four locking bolts in type I

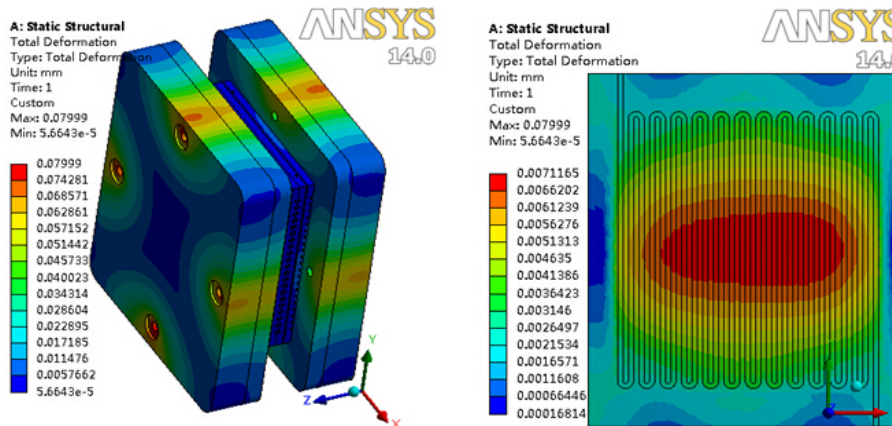

(a) The overall displacement contour

(b) The displacement contour of bipolar plate

Fig. 3 The displacement contour with four locking bolts in type II

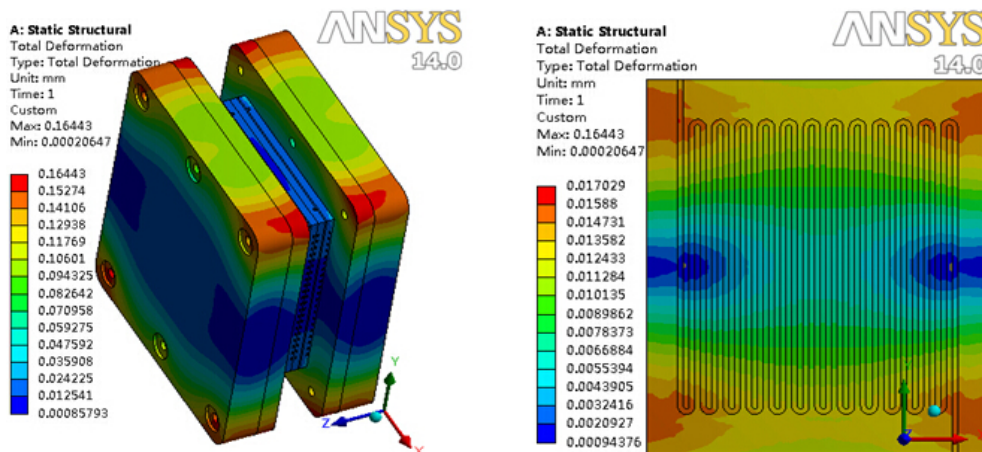

(a) The overall displacement contour

(b) The displacement contour of bipolar plate

Fig. 4 The displacement contour with six locking bolts in type I

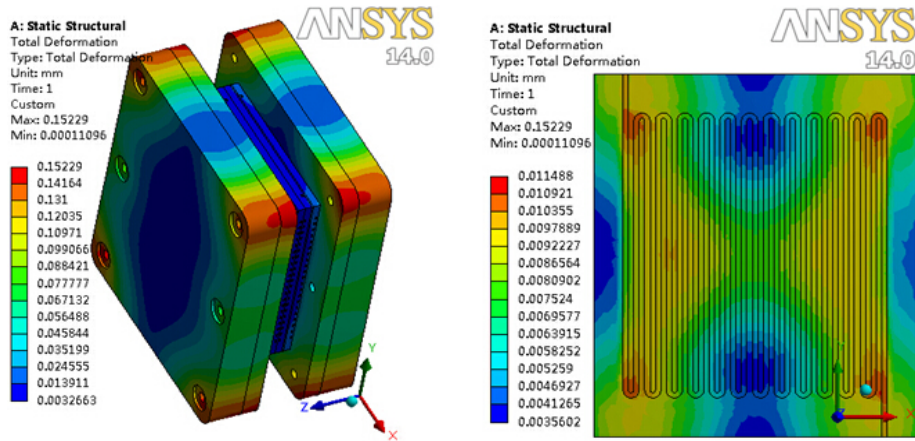

(a) The overall displacement contour

(b) The displacement contour of bipolar plate

Fig. 5 The displacement contour with six locking bolts in type II

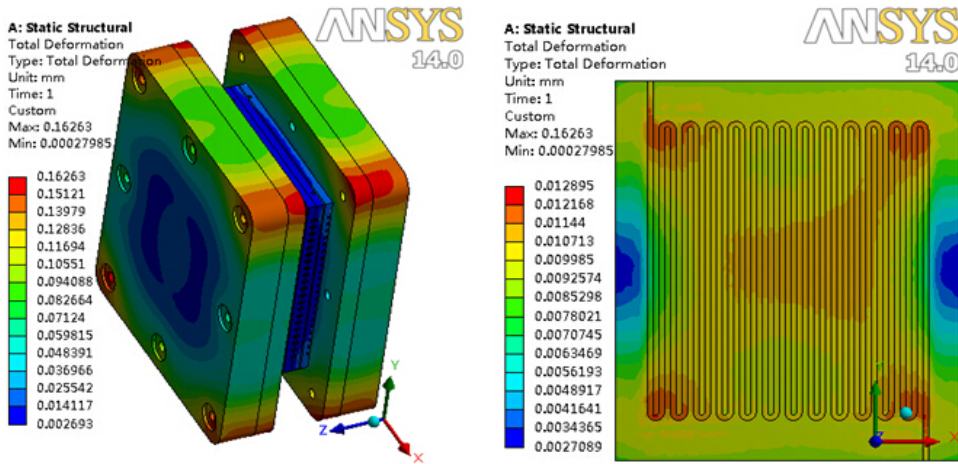

(a) The overall displacement contour

(b) The displacement contour of bipolar plate

Fig. 6 The displacement contour with eight locking bolts in type I

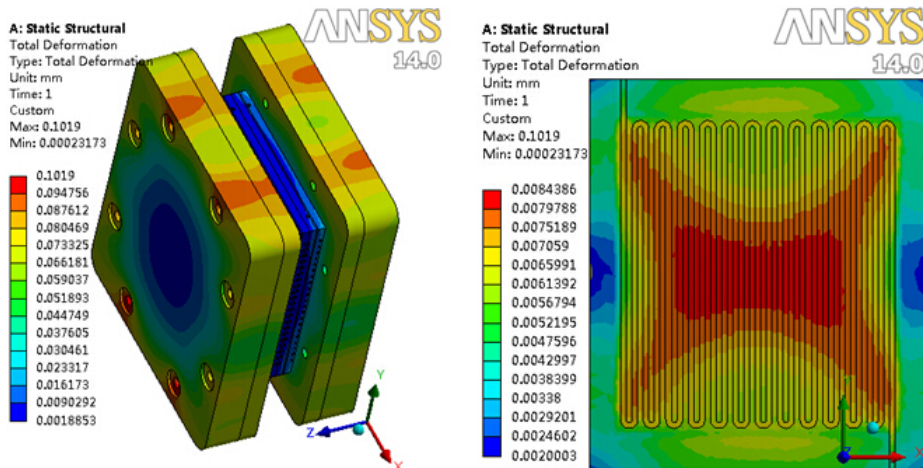

(a) The overall displacement contour

(b) The displacement contour of bipolar plate

Fig. 7 The displacement contour with eight locking bolts in type II

As shown in Fig. 9, at the guarantee of the same clamping pressure, with a given size of the fuel cell stack, the displacement deformation of bipolar plate is greatly different when the quantity and the layout of locking bolts are inconsistent. Even the quantity is the same, but the layout is different, there will have a different effect also. Thus, it is not the more locking bolts, the smaller deformation of the bipolar plate, but connects with the layout of locking bolts on the bipolar plate. It can be seen from Fig. 9 (c), the curve with type I of four locking bolts along the given path S (i.e. diagonal) is smoother, but for (a) and (b) in Fig. 9, the curve with type II of four locking bolts is smoother compared to the others. So, considering comprehensively, the better effect of the assembly with entire stack of PEMFC can be achieved using the layout of locking bolt with the type II of four locking bolts.

V. THE EFFECT OF THE BOLT LOCKING FORCE ON THE DEFORMATION OF THE BIPOLAR PLATE

From the previous analysis, we have learned that the magnitude of the bolt locking force will affect the performance of the PEMFC. For each fuel cell stack with fixed structure and size, and according to the best quantity and layout of locking bolt from the above, there must be a certain magnitude of the upper/lower limit value for bolt locking force to make the deformation degree of bipolar plate best. The upper limit value of the bolt locking force is the maximum locking force before the PEMFC components produce plastic deformation or crushing damage; the lower limit locking force is the minimum clamping force to ensure the fuel cell does not leak gas or water. Using finite element simulation analysis method to determine the best locking force of PEMFC stack with the given size is an effective method, with three-cell stack of PEMFC as the research object, to study the best magnitude of bolt locking force to make the effect of assembly with PEMFC stack

optimum.

The literature [10] shows that, for the Nafion membrane of PEMFC, when applied torque to the bolt to make the pressure of fuel cell stack reaches 6.14 MPa, it will reach the yield strength of the membrane. If the pressure is further increased, it would cause damage to the membrane. In this paper, in order to make the best bolt clamping pressure to be universal, the maximum value of the total pressure applied to all bolts on the fuel cell is determined at 8 MPa. The specifications of the bipolar plate still exemplified the rectangular (100 mm×86 mm) plate. Eight relatively reasonable clamping pressures (respectively 1 MPa, 2 MPa, 3 MPa, 4 MPa, 5 MPa, 6 MPa, 7 MPa and 8 MPa) on the bipolar plate are given to simulate and analyze the influence of the bolt locking force on the deformation of the bipolar plate. Then, according to the results of the simulation, the optimum bolt clamping pressure is obtained.

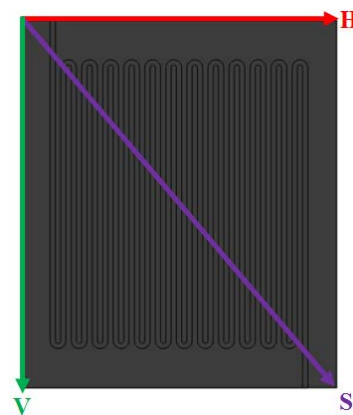

Fig. 8 The defined path

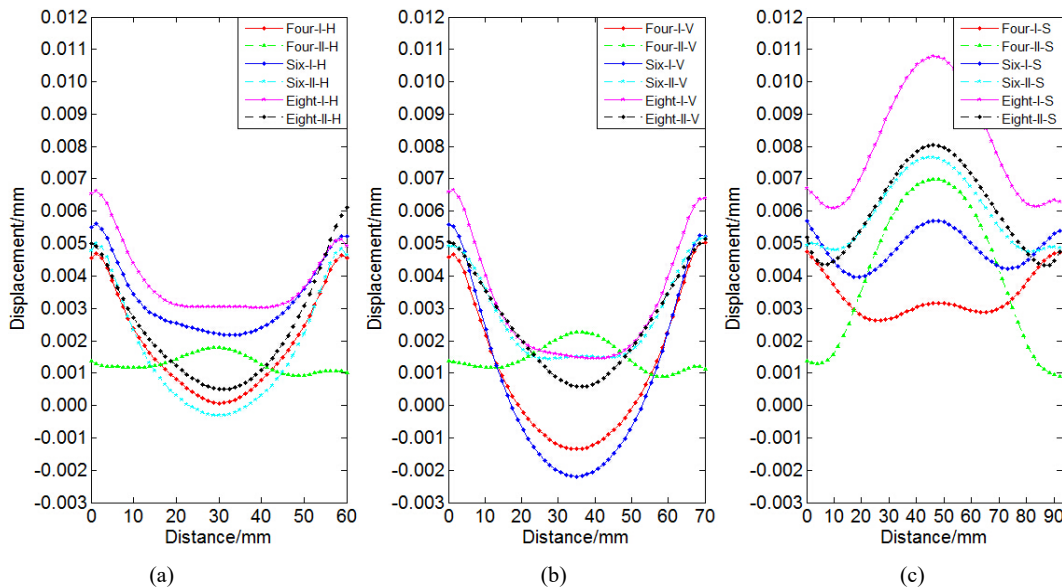

Fig. 9 The deformation curve with different quantity and layout of locking bolts along the three paths in the Z direction (a) The displacement along the Z-direction (path H), (b) The displacement along the Z-direction (path V), (c) The displacement along the Z-direction (path S)

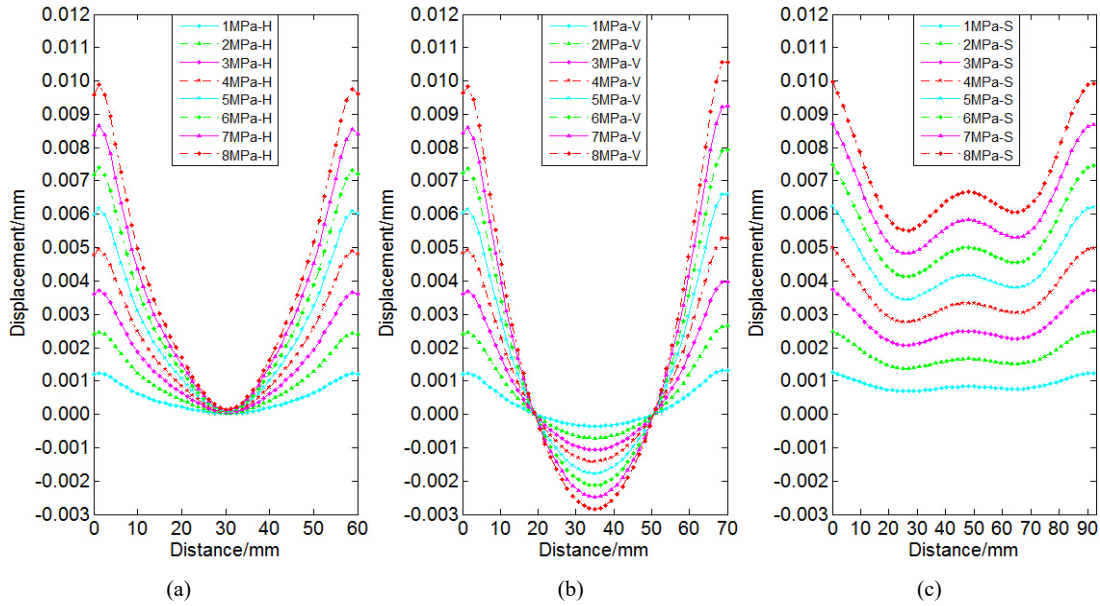

Fig. 10 The deformation curve along the three paths in Z direction when the range of locking pressure is from 1MPa to 8MPa (a) The displacement of Z direction along H path, (b) The displacement of Z direction along V path, (c) The displacement of Z direction along S path

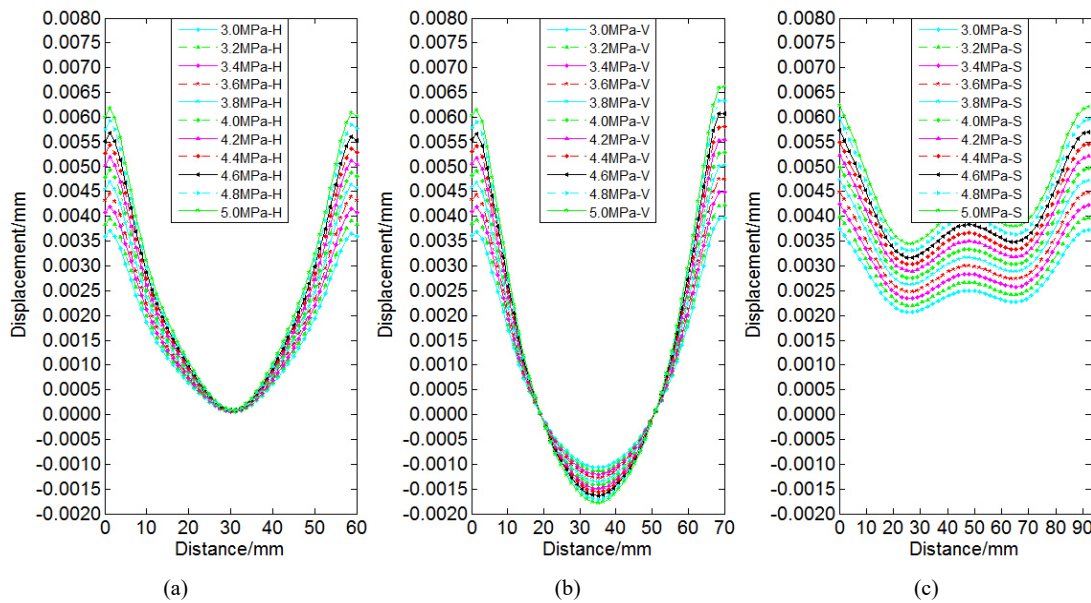

Fig. 11 The deformation curve along the three paths in Z direction when the range of locking pressure is from 3.0MPa to 5.0MPa (a) The displacement of Z direction along H path, (b) The displacement of Z direction along V path, (c) The displacement of Z direction along S path

In order to further study the deformation rule of the PEMFC bipolar plate caused by the bolt locking force so that the optimum locking force is achieved, ANSYS/workbench software is used to analyze the displacement tendency of bipolar plate along the X direction (H), Y direction (V) and diagonal direction (S) respectively as shown in Fig. 8. To discuss absolute displacement on the paths of bipolar plate, MATLAB software is used to process a series of data from simulation results, and drawing the deformation curve of the bipolar plate displacements along the given path when the

range of locking pressure is from 1MPa to 8MPa. As shown in Fig. 10, the horizontal coordinate represents the distance along the given path, and the vertical coordinate indicates the absolute displacement of the corresponding horizontal coordinate in the Z direction. The range of the three paths is 0~60mm (H), 0~70mm (V), 0~92.195mm (S). In order to compare the absolute deformation of different paths in the direction of Z, the longitudinal coordinates of the finger all take the same range, that is, -0.003~0.012mm. It can be seen from Fig. 10 (b), that the longitudinal coordinate of the displacement

curve along V path at the given clamping pressure from 4MPa to 8MPa has a value of positive and negative. This is due to the ANSYS/Workbench software analysis of the displacement distribution is based on the absolute displacement value. The negative value indicates that the position of the bipolar plate has a certain displacement deformation along the -Z direction, and the displacement of the concave (observed in the +Z direction) is larger than the convex. It can be found from Fig. 10 that those shape of curves is similar, and the displacement curves along H path in the Z direction is almost symmetrical. In Fig. 10, the curves of figure (a) and figure (b) are obviously a "U" type, while the figure (c) is a "W" type. This is because that the PEMFC assembled with type II of four locking bolts (as shown in Fig. 1 (d)) makes the displacement deformation at the four corners of bipolar plate be larger than the center. Resulting in the around of bipolar plate is extruded toward to the middle so that the middle of the bipolar plate become bulged. Therefore, there is an obvious bulge at the middle of the displacement in Fig. 10 (c).

In addition, we can obtain it from the Fig. 10 that when the locking bolt pressure is 1~3 MPa, the deformation of bipolar plate is relatively uniform and small, but the seal performance of overall PEMFC is poor at this pressure and may cause leak of the reaction gas, resulting in danger; when the pressure is 5~8 MPa, the deformation of bipolar plate is larger and nonuniform, and the larger pressure range may cause some components of PEMFC crushed, such as the poor mechanical strength of GDL or PEM. When the locking bolt pressure is 3~5 MPa, the deformation of the bipolar plate is small, and the seal performance of the overall PEMFC stack is better. Thus, the locking pressure is initially reduced to a range of 3~5 MPa.

In order to improve the performance of assembly further and find the optimal pressure, we will reduce the range of the bolt locking pressure. So, we will continue to divide the range of 3~5 MPa into 3.0 MPa, 3.2 MPa, 3.4 MPa, 3.6 MPa, 3.8 MPa, 4.0 MPa, 4.2 MPa, 4.4 MPa, 4.6 MPa, 4.8 MPa, 5.0 MPa for analysis. Finally, the figure of displacement and deformation trend at the 11 pressure values along the given path is obtained as shown in Fig. 11.

It can be seen from Fig. 11 that the shape of the bipolar plate deformation curve along the three paths in the Z direction is similar to Fig. 10. The displacement deformation curve of Fig. 11 shows that, when the clamping pressure is in the vicinity of 4MPa, the displacement curve of the bipolar plate is better, so it can be further inferred that the value of optimal locking pressure is in the vicinity of 4 MPa. In order to find out the optimal locking pressure accurately, the polarization curves of PEMFC at the range of 3.4 MPa~4.2 MPa are divided into five nodes. Except for the clamping pressure, other parameters of the PEMFC stack are the same, as shown in Fig. 12. When the current density is relatively small, and the output voltage is larger than 0.7 V, the polarization curves at the five pressure points have a significant voltage drop and the degree of reduction is basically consistent. This part of the voltage drop is mainly caused by the loss of cell activation, and the influence of the locking pressure is relatively small, so when the output voltage is larger than 0.7 V, the output current density

corresponding to the five pressure points is essentially the same. As the voltage goes to decrease, the polarization curve is substantially linear. This is because in the work area, the activation loss of PEMFC is stabilized instead of changing with the current, and the ohmic loss of the PEMFC is related to the resistance of the PEMFC itself. When the output current is not high, the consumption of reaction gas is not much and still can maintain higher gas concentration, so the loss of concentration is also very small, and the polarization curve will be showing a linear trend.

In general, the increasing of clamping pressure will decrease the porosity of diffusion layer and the interfacial contact resistance, which caused that under the same PEMFC output voltage, the current density of the PEMFC will increase with the increasing of clamping pressure. When the clamping pressure reaches a marginal value, the permeability of reaction gas is blocked severely and resulting in deterioration of mass transfer, so the performance of the PEMFC will be influenced greatly. As can be seen from Fig. 12, at the range of 3.4 MPa ~ 4.2 MPa, with the increase of the bolt locking pressure, the performance of PEMFC increased firstly and then decreased. When the clamping pressure is 3.8 MPa, the performance of the PEMFC is optimal, that is to say that the optimal locking pressure of the FC stack is 3.8 MPa.

VI. THE EFFECT OF BOLT LOCKING SEQUENCE ON THE DEFORMATION OF THE BIPOLAR PLATE

In order to facilitate the subsequent discussion and based on the conclusion of the optimal quantity and layout of the locking bolt, using the type II of four locking bolts to analyze the effect of bolt locking sequence on the bipolar plate in PEMFC. As shown in Fig. 13, the bolts on the bipolar plate are numbered from 1 to 4 respectively. There are many kinds of bolt locking sequences and take the comparison of several typical groups to discuss. Including: clockwise locking (1-2-3-4, 2-3-4-1), counterclockwise locking (1-4-3-2, 4-3-2-1), transverse locking (4-2-1-3, 4-2-3-1), and longitudinal locking (1-3-4-2, 1-3-2-4), there is a total of eight kinds of locking sequence.

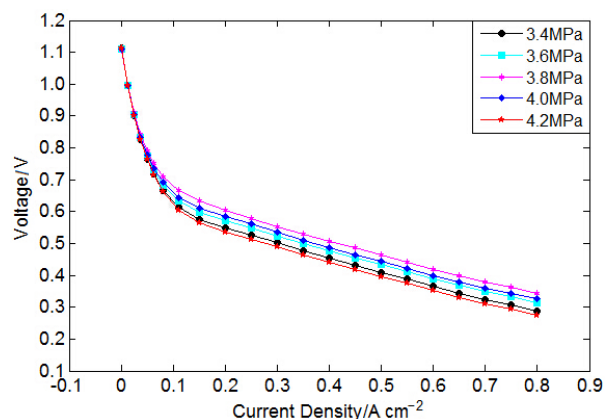

Fig. 12 Polarization curves under different locking pressure

In order to simplify the analysis form of the impact caused by

bolts locking sequence on bipolar plate, we select one locking sequence of each locking method to carry out the finite element simulation analysis, those bolt locking sequences are 1-2-3-4, 1-4-3-2, 4-2-1-3, 1-3-4-2, respectively. The results of simulation are shown in Figs. 14-17. These photographs show the overall displacement contour at the locking of the different bolts (the number as shown in Fig. 13) in turn.

From Figs. 14-17 we can see that, during the process of locking of every kind of locking sequence with bolts, the deformation displacement contour of assembly of PEMFC stack changed with the changing of bolt locking sequence, but when the bolts locked stability, the overall deformation of each component remains the same basically. Therefore, only from the deformation displacement contour, it cannot fully explain the effects of bolt locking sequence on the deformation of stable locked PEMFC stack. There need other paths to analyze the effect on the deformation of the bolts locking sequence to the PEMFC stack. Based on the H and V paths of the bipolar plates defined in Fig. 8, the deformation curve caused by locking sequence of the bolt on the bipolar plate along the H and V paths in the Z direction is analyzed and studied as shown in Fig. 18. It is known that, for the longitudinal locking method that whatever along the given path H or the given path V in the

Z direction, the deformation curves of bipolar plate is optimal. That is, the displacement deformation of two locking sequences on the bipolar plate contained in longitudinal locking method along the H and V path in the Z direction is small and relatively smooth. It shows that the effect of two locking sequence in the longitudinal contained in eight bolt locking sequences is the best. So, for the given specifications of assembly of the PEMFC stack in this paper, the longitudinal locking method can obtain the best effect on the deformation displacement of bipolar plate.

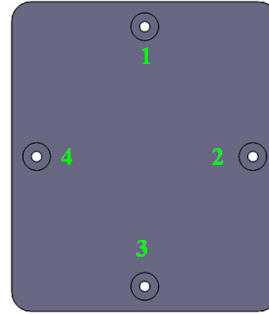

Fig. 13 The number of bolts

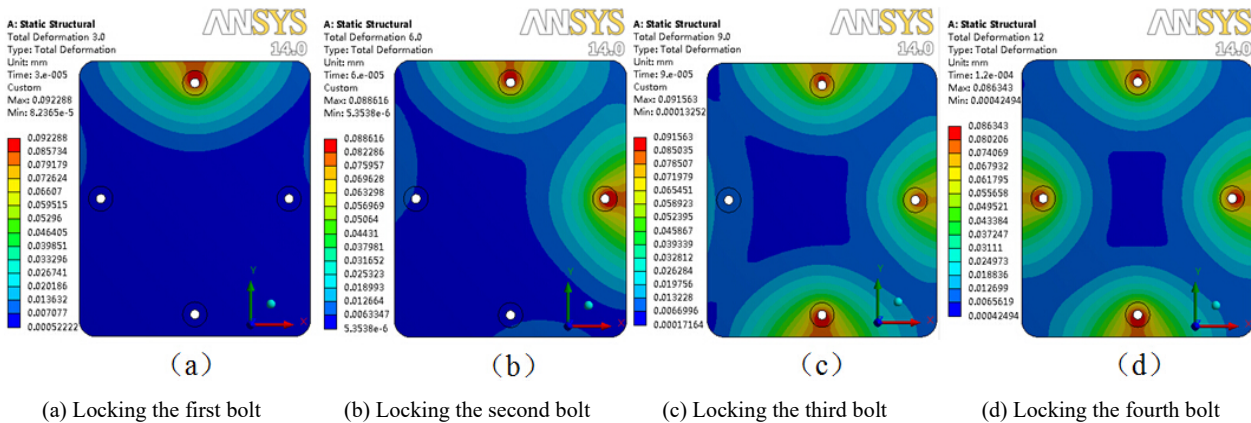

Fig. 14 The overall displacement contour of the bipolar plate at the clockwise locking (1-2-3-4)

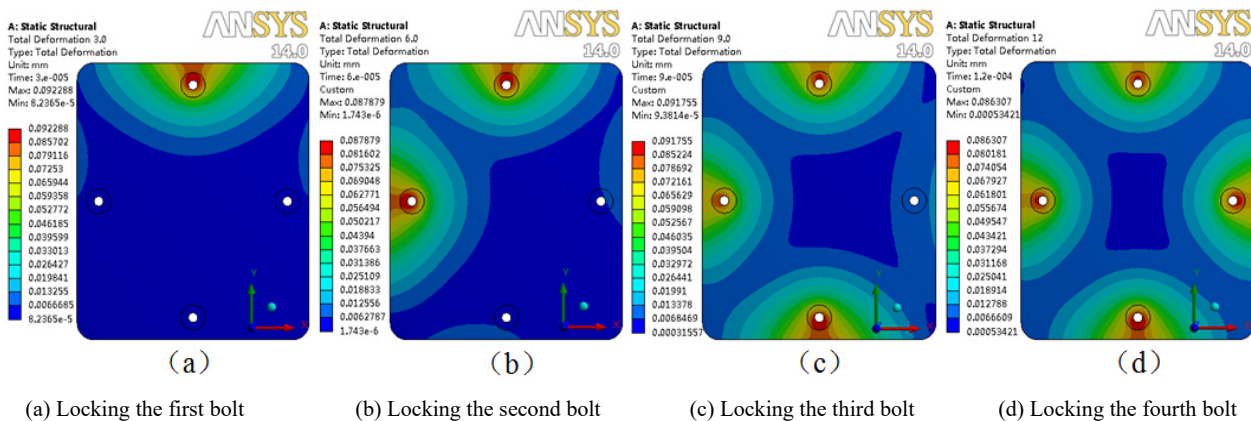
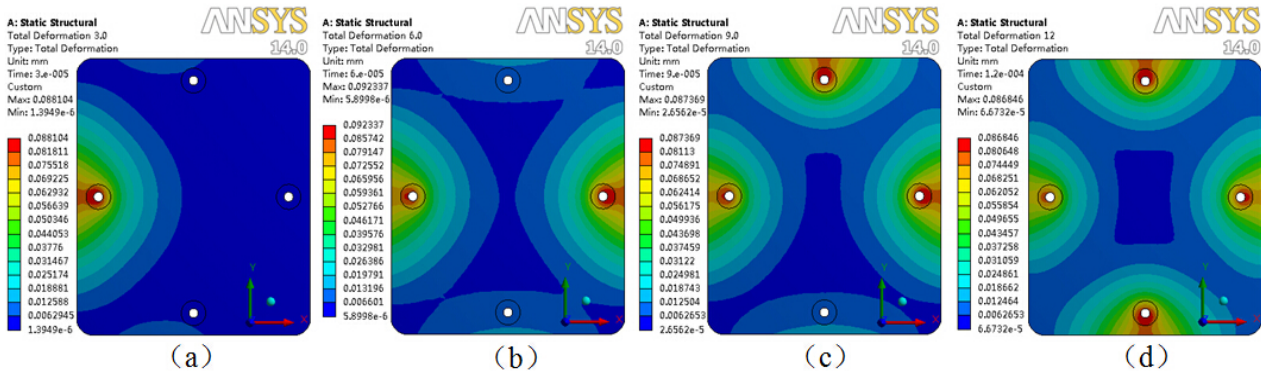
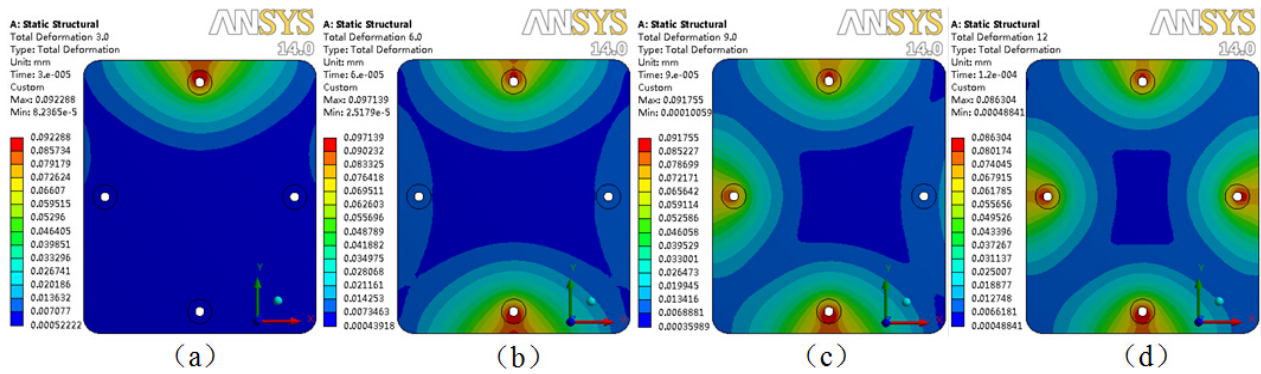

Fig. 15 The overall displacement contour of the bipolar plate at the counterclockwise locking (1-4-3-2)



(a) Locking the first bolt (b) Locking the second bolt (c) Locking the third bolt (d) Locking the fourth bolt

Fig. 16 The overall displacement contour of the bipolar plate at the transverse locking (4-2-1-3)



(a) Locking the first bolt (b) Locking the second bolt (c) Locking the third bolt (d) Locking the fourth bolt

Fig. 17 The overall displacement contour of the bipolar plate at the longitudinal locking (1-3-4-2)

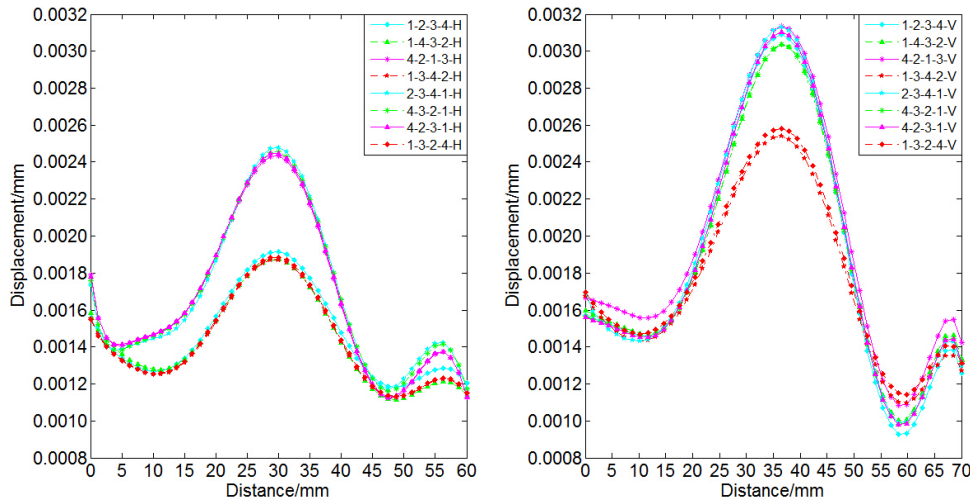

(a)The displacement of Z direction along H path (b)The displacement of Z direction along V path

Fig. 18 Deformation curves of bipolar plates along the H and V paths in the Z direction by eight kinds of locking sequence

VII. CONCLUSION

The assembly method of PEMFC stack will affect the performance of PEMFC directly. Based on the analysis of finite element simulation, this paper combines the theoretical

analysis with numerical simulation method, and with the three-cell stack of PEMFC as the research object, focuses on the analysis with the effects of loading method (such as the quantity and layout of bolts, bolt locking pressure and bolt

locking sequence etc.) on deformation of bipolar plate in PEMFC, and then get the optimum method of bolt locking. There are some conclusions as follows:

- 1) With three-cell stack of PEMFC, a given size of the bipolar plate in PEMFC is simulated and analyzed. The deformation of bipolar plate with six kinds of bolt layout in the same clamping pressure is simulated. According to the analysis of simulation data, the displacement deformation of the bipolar plate along the given paths in the Z direction is obtained. Comparing with these results, the conclusion can be achieved that when adopting the type II of four locking bolts to assemble the FC, the deformation of the bipolar plate is minimal and more uniform. That is, the optimal layout of locking bolts is the type II of four locking bolts;
- 2) Based on the optimal layout of the locking bolt, the analysis of finite element simulation is carried out for the optimal locking pressure of the PEMFC stack with a given size. According to the curves of the absolute displacement of the bipolar plate along the given three paths in the Z direction, and gradually reduced the locking pressure to a reasonable range. By the analysis, we inferred that the optimal locking pressure is near 4 MPa. According to the analysis of the polarization curve, the best performance of the PEMFC is obtained when the locking pressure is 3.8 MPa, that is, the optimal locking pressure of the locking bolt is 3.8 MPa;

According to the above conclusion of the optimal quantity and layout of the locking bolts, the analysis of finite element simulation is carried out by using the distribution of type II with four locking bolts compared with the results of the simulation with the clockwise locking, the counterclockwise locking, the lateral locking and the longitudinal locking. With the analysis of the deformation curve of the bipolar plate along the H and V path in the Z direction, it can be known that the displacement deformation with two locking sequences contained in longitudinal locking along the H path and V path in the Z direction is small and relatively smooth. That is, the two locking sequences which are included in the eight kinds of bolt locking sequences can get the best effect. So, for the PEMFC stack in this paper, the method of longitudinal locking can be used to obtain the best displacement deformation of the bipolar plate.

ACKNOWLEDGMENT

The authors would like to thank the National Science Foundation of China (Grant Number: 51575413) for funding this study.

REFERENCES

- [1] T. Fukutsuka, T. Yamaguchi, S. Miyano, Y. Matsuo, Y. Sugie, Z. Ogumi, "Carbon-coated stainless steel as pemfc bipolar plate material," *Journal of power sources*, vol. 174, no.1, pp. 199-205, 2007.
- [2] K. Feng, Y. Shen, D. Liu, P. K. Chu, X. Cai, "Ni-Cr co-implanted 316L stainless steel as bipolar plate in polymer electrolyte membrane fuel cells," *International journal of hydrogen energy*, vol.35, no. 2, pp. 690-700, 2010.
- [3] P. Lin, P. Zhou, C. W. Wu, "A high efficient assembly technique for large pemfc stacks part I. Theory," *Journal of power sources*, vol.194, no. 1, pp. 381-390, 2009.
- [4] C. Carral, N. Charvin, H. Trouvé, P.mélé, "An experimental analysis of pemfc stack assembly using strain gage sensors," *International journal of hydrogen energy*, vol. 39, no.9, pp. 4493 -4501, 2014.
- [5] S. Lee, C. Hsu, C. Huang, "Analyses of the fuel cell stack assembly pressure," *Journal of power sources*, vol.145, no. 2, pp. 353-361, 2005.
- [6] D. Qiu, P. Yi, I. Peng, X. Lai, "Assembly design of proton exchange membrane fuel cell stack with stamped metallic bipolar plates," *International journal of hydrogen energy*, vol. 40, no. 35, pp. 11559 -11568, 2015.
- [7] D. H. Ahmed, H. J. Sung, J. Bae, "Effect of gdl permeability on water and thermal management in pemfcs-ii. Clamping force," *International journal of hydrogen energy*, vol.33, no. 14, pp. 3786 -3800, 2008.
- [8] P. Zhou, C. W. Wu, G. J. Ma, "Influence of clamping force on the performance of pemfcs," *Journal of power sources*, vol.163, no. 2, pp. 874-881, 2007.
- [9] A. Bazylak, D. Sinton, Z. S. Liu, N. Djilali, "Effect of compression on liquid water transport and microstructure of pemfc gas diffusion layers," *Journal of power sources*, vol.163, no. 2, pp. 784-792, 2007.
- [10] C. Wen, Y. Lin, C. Lu, "Experimental study of clamping effects on the performances of a single proton exchange membrane fuel cell and a 10-cell stack," *Journal of power sources*, vol.192, no. 2, pp. 475-485, 2009.
- [11] I. Gatto, F. Urbani, G. Giacoppo, O. Barbera, E. Passalacqua, "Influence of the bolt torque on pemfc performance with different gasket materials," *International journal of hydrogen energy*, vol. 36, no. 20, pp. 13043 -13050, 2011.
- [12] S. Yim, B. Kim, Y. Sohn, Y. Yoon, G. Park, W. Lee, C. Kim, Y. C. Kim, "The influence of stack clamping pressure on the performance of pem fuel cell stack," *Current applied physics*, vol. 10, no. 2, pp. s59-s61, 2010.
- [13] P. Chippar, K. O, K. Kang, H. Ju, "A numerical investigation of the effects of gdl compression and intrusion in polymer electrolyte fuel cells (pemfcs)," *International journal of hydrogen energy*, vol. 37, no. 7, pp. 6326-6338, 2012.
- [14] V. Radhakrishnan, P. Haridoss, "Effect of cyclic compression on structure and properties of a gas diffusion layer used in pem fuel cells," *International journal of hydrogen energy*, vol. 35, no. 20, pp. 11107 -11118, 2010.
- [15] C. Carral, P. Mélé, "A numerical analysis of pemfc stack assembly through a 3d finite element model," *International journal of hydrogen energy*, vol.39, no. 9, pp. 4516-4530, 2014.
- [16] X. Lai, D.A. Liu, I. Peng, J. Ni, "A mechanical-electrical finite element method model for predicting contact resistance between bipolar plate and gas diffusion layer in pem fuel cells," *Journal of power sources*, vol. 182, no. 1, pp. 153-159, 2008.
- [17] Chi-Hui Chien, Yao-Lun Hu, Ting-Hsuan Su, Hsuan-Ting Liu, Chung-Ting Wang, Ping-Feng Yang, Ying-xu lu, "Effects of bolt pre-loading variations on performance of gdl in a bolted pemfc by 3-d fem analysis," *Energy*, vol.113, pp. 1174-1187, 2016.
- [18] Jason Millichamp, Thomas J. Mason, tobias P. Neville, Natarajan rajalakshmi, Rhodri Jervis, Paul r. Shearing, Daniel j.l. Brett, "Mechanisms and effects of mechanical compression and dimensional change in polymer electrolyte fuel cells-a review," *Journal of power sources*, vol.284, pp. 305-320, 2015.