

Three Dimensional Dynamic Analysis of Water Storage Tanks Considering FSI Using FEM

S. Mahdi S. Kolbadi, Ramezan Ali Alvand, Afrasiab Mirzaei

Abstract—In this study, to investigate and analyze the seismic behavior of concrete in open rectangular water storage tanks in two-dimensional and three-dimensional spaces, the Finite Element Method has been used. Through this method, dynamic responses can be investigated together in fluid storage system. Soil behavior has been simulated using tanks boundary conditions in linear form. In this research, in addition to flexibility of wall, the effects of fluid-structure interaction on seismic response of tanks have been investigated to account for the effects of flexible foundation in linear boundary conditions form, and a dynamic response of rectangular tanks in two-dimensional and three-dimensional spaces using finite element method has been provided. The boundary conditions of both rigid and flexible walls in two-dimensional finite element method have been considered to investigate the effect of wall flexibility on seismic response of fluid and storage system. Furthermore, three-dimensional model of fluid-structure interaction issue together with wall flexibility has been analyzed under the three components of earthquake. The obtained results show that two-dimensional model is also accurately near to the results of three-dimension as well as flexibility of foundation leads to absorb received energy and relative reduction of responses.

Keywords—Dynamic behavior, water storage tank, fluid-structure interaction, flexible wall.

I. INTRODUCTION

DYNAMIC interaction between fluid and structure is one of the most important issues in many of engineering problems. These issues and problems include different systems such as submerged and off-shore structures, bio-mechanical systems, aircraft, suspension bridges and storage tank. This interaction can significantly change the seismic features in the structure and finally it ends to the periodic and transient response. Therefore, it is suggested that the various systems with fluid-structure interaction (FSI) should be modeled. One of the most important structures has been developed during the recent decades is fluid storage tank. These structures can widely be used in water supply facilities, oil and gas industry and nuclear power plants for storing all kinds of fluids or liquids materials such as oil, liquefied natural gas (LNG), chemical liquids and waste with different forms.

Fluid tanks are subjected to a wide range of seismic hazards and interact with other parts of environment. Heavy damages have been reported due to the frequent and strong earthquakes

S.Mahdi. S.Kolbadi is M.Sc. in Civil Engineering from K.N.Toosi University of Technology, Tehran, Iran (corresponding author, e-mail: Mahdi_kolbadi@sina.kntu.ac.ir).

Ramezan Ali. Alvand and Afrasiab Mirzaei are M.Sc. in Civil Engineering from Loghman Hakim, Agh Ghala, Iran (e-mail: ramezanalialvand@gmail.com, afrasiab.mirzaei@gmail.com).

[2], [3], [5], [8], [9].

The achieved progresses in prediction of computational simulations have become a help for engineers to predict the possible damages and design. In the past few decades, the tendency in designing these systems has effectively been led to high increase in creating the mechanical models to predict the impact of FSI in fluid tank behavior. From the numerical view, the simulation of these systems can be done based on the use of the frequency domain or according to the models of domain. The first way is more suitable for design applied programs, while the next way is more realistic to predict the tank interaction seismic behavior and fluid under recorded earthquake.

At the present time, many of the current design codes such as ACI 350.6 by considering the boundary conditions of rigid wall are used to calculate the hydrodynamic pressure. The effects of tanks' body flexibility on its dynamic responses should be investigated. Furthermore, rectangular fluid tanks are typically being analyzed using a two-dimensional model that is placed on rigid foundation. Such hypotheses may be unreal and more research is needed [16]. The aim of this study is to obtain better understanding of real behavior of rectangular concrete tanks under seismic loading.

A. Fluid Reservoir Analysis Methods

Seismic analysis of concrete rectangular tanks should be started with simple methods at any time and in the emergency and necessary situations should be reached to a more advanced analysis. In some cases, this analysis may provide significant preliminary parameters that are important for structural response [4].

B. Simplified Method

Simplified methods are used for preliminary estimates of tensions and shear forces with regards to seismic loading. Traditional seismic coefficient is a method that is mainly used for analyzing rigid hydraulic structures or almost rigid. In this method the inertial forces in structures and added mass in water are displayed with regards to seismic shaking by static forces applied at the gravity center of systems. Inertial forces are simply calculated from the results of structural mass or water load added mass with an appropriate seismic coefficient in accordance with design codes [16].

C. Response Spectrum Analysis Method

The maximum of linear elastic response in concrete liquid tanks can be met by using the response spectrum in a perfect location status. This method is suitable for design, but it can also be used to analyze the liquid tanks that are subjected to

ground motions that create linear elastic response. In response to spectrum analysis, the maximum displacement, tensions and shear forces are estimated at first mode then the combination for all considerable modes would be calculated. Specified responses with respect to each component in earth movement have been combined using the sum of the squares (SRSS) or by complete quadratic combination (CQC) method. SRSS combination method is suitable if the vibration modes of it are well separated [2].

D. Time-History Analysis

Time-history analysis has been done to prevent many of limitations in respond spectrum method as well as to describe time-dependent respond in structure and a better display of foundation-structure interaction effects and FSI. Earthquake input for time-history analysis is usually in form of acceleration of time-history that it accurately determines many of earthquake aspects such as duration of time, number of cycles, pulses with high-energy and determination of pulse sequencing. Time-history analysis is the only proper way to estimate damages in structures [15].

E. Literature Review

The seismic performance of storage tanks has special importance that is greater than the value of tank and its contents. If we are not aware of storage of water, the uncontrollable conflagration after a powerful earthquake will cause damages more than the earthquake itself, a case that

happened in a great earthquake of San Francisco in 1906. After occurrence of a destructive earthquake, providing safe drinking water is also an extremely important issue to prevent the outbreak of diseases. Consequently, water storage tank must remain functional after earthquakes. Failure of tanks containing petroleum products is highly flammable that causes to expand uncontrollable fires.

Concrete storage tanks are also subjected to significant damages. Many concrete storage tanks are damaged in Chile earthquake in 1960 and Beijing earthquake in 2001 [15]. Also, according to Sung report from the earthquake of Kobe, severe damages have been happened for underground concrete rectangular tanks [10].

One of the oldest studies, reported by Haroun and Tayel, is for analytical and experimental investigation of developed hydrodynamic pressure in rectangular tanks when they are subjected to horizontal motion [5]. Then, Rashed and Iwan provided the designed curves based on Hasner model to estimate bending and torsion resulting from hydrodynamic pressure for both cylindrical and rectangular tanks [9].

The first computer program used for analyzing FSI issue has been reported by Westergaard in 1938 [14]. Finite element method along with modified shell theory has been used to predict tensions and shift of places in fluid-filled cylindrical container that the ratio of its height to diameter is smaller than one. In this study elastic wall interaction in tank and its fluid will be discussed (Fig. 1).

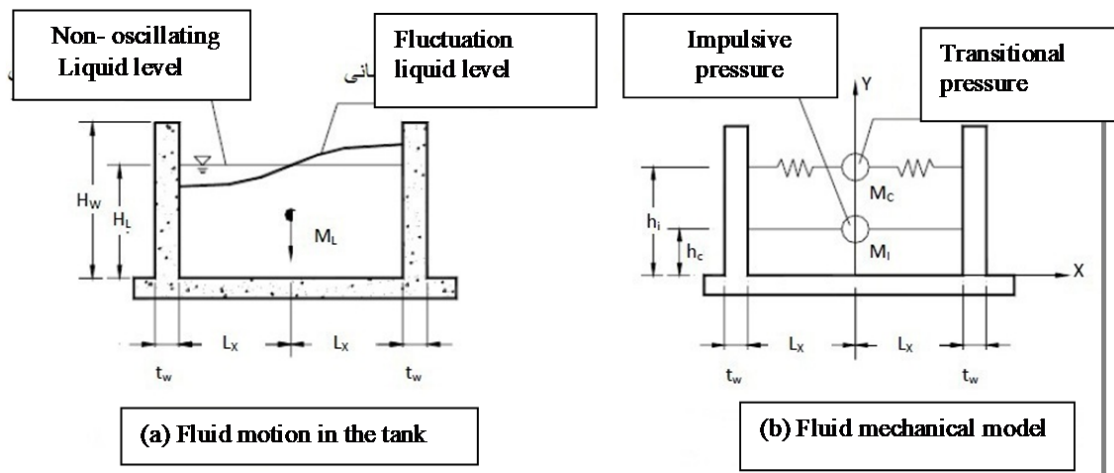

Fig. 1 Hasner model

Young studied and investigated the effects of wall flexibility on pressure distribution in fluid and relevant forces in tank structure through an analytical method using one degree of freedom system with different modes of vibrations [15]. And also, Veletos and Tang developed the flexible attached storage linear models and they found that pressure distribution had been similar in thermal state of rigid and flexible tanks [12]. Also, they discovered that the value of this pressure is highly depended on the flexibility of wall. It was found that the hydrodynamic pressure in a flexible tank can

significantly be higher than corresponding rigid tank with regards to the impact of flexible structure interaction and existing liquid.

Tait investigated and analyzed the impact of flexibility of the tank walls and hydrodynamic pressure acting on the wall. As well as, experimental studies have been done to determine the dynamic characteristics of rectangular tanks [11].

Kianoush analyzed fluid storage tanks that were subjected to the vertical motion of earth under both rigid and flexible states. It has been cleared that soil-structure interaction causes

to reduce the hydrodynamic impacts [6].

Harun and Abolezdain has done a parametric research about various effective factors in seismic interaction of cylindrical tank and soil under both horizontal and vertical stimulations by using idealization of compression parameters on the foundation [5].

Mirzabozorg et al. provided a modified method to analyze impulsive and thermal components in respond to liquid storage tanks. They found that thermal components are not sensitive in respond to flexibilities of tanks walls and supportive soils and they can be calculated with regards to rigidity of tank wall and supportive soils [8].

Rashed et al. developed analytical solution methods and provided full flexible rectangular tanks response. Their method is simple and appropriate for pragmatic aims, but flexibility of wall is not completely considered [9]. McVerry et al. have done studies on dynamic response of rectangular tanks. They used boundary element method (BEM) to obtain hydrodynamic pressure distribution and finite element method (FEM) for analyzing rigid wall [7].

Maqami and Kyanooosh studied seismic behavior of rectangular liquid reservoirs in two-dimensional space. In this study, two different models of finite element with depth and shallow reservoirs shapes that are placed on rigid base under the influence of vertical and horizontal movements of the earth were studied. The effects of FSI on dynamic response of fluid reservoirs as well as flexibility of wall were considered and analyzed [4]. The results have shown that flexibility of wall and fluid damping properties have important effect on seismic behavior of liquid tanks. Usually, the impact of vertical component of acceleration is not as important as horizontal component on dynamic response of liquid storage tanks.

II. PROCEDURES AND METHODS

A. Water-Structure Interaction

The equation governing on fluids behaviors (non-viscous) or the Helmholtz equation (1) includes:

$$\frac{1}{c^2} \cdot \frac{\partial^2 P}{\partial t^2} - \nabla^2 P = 0 \tag{1}$$

where P is pressure and C is velocity of the wave in fluid. Structural environment is governed by (2):

$$\sigma_{i,jj}(u) + \rho_s \ddot{u}_i = 0 \tag{2}$$

where $\sigma_{i,jj}$ is stress, \ddot{u}_i is acceleration and ρ_s is density of structure. In fluid and structure interface, fluid pressure is transmitted to structure and structure shift affects the fluid:

$$\{n\} \cdot \{\nabla P\} = -\rho \{n\} \frac{\partial^2 \{u\}}{\partial t^2} \tag{3}$$

where $\{n\}$ is the normal vector at the interface between fluid and structure. Finally, (4)-(6) are developed to implement the FSI interaction in common boundary of reservoir and dam body:

$$\begin{bmatrix} [M_e^s] & [0] \\ [M_e^{fsi}] & [M_e^p] \end{bmatrix} \cdot \begin{Bmatrix} \{\ddot{u}_e\} \\ \{\ddot{p}_e\} \end{Bmatrix} + \begin{bmatrix} [K_e^s] & [K_e^{fsi}] \\ [0] & [K_e^p] \end{bmatrix} \cdot \begin{Bmatrix} \{u_e\} \\ \{p_e\} \end{Bmatrix} = \begin{Bmatrix} \{F_e\} \\ \{0\} \end{Bmatrix} \tag{4}$$

in which:

$$[M_e^{fsi}] = \rho \cdot [R_e]^T \tag{5}$$

$$[K_e^{fsi}] = -\rho \cdot [R_e] \tag{6}$$

in which $[M_e^s]$, $[K_e^s]$, $[M_e^p]$ and $[K_e^p]$ respectively are matrixes of mass and fluid-structure stiffness and $[R_e]$ is water-structure matrix and is calculated from:

$$\rho \cdot [R_e] = \rho \int_s \{V\} \{n\}^T \{N\}^T \cdot dS \tag{7}$$

The Fluid29 is the fluid elements that are developed in ANSYS software based on (4). The performance of this element in fluid hydrodynamic pressure modeling is controllable [1].

B. Soil-Structure Interaction

Rashed provided a short investigation about general methods used in interaction modeling between soil system and foundation and structure [9]. There are two common and prevalent methods for analyzing seismic behavior of structures includes soil-structure interaction (SSI):

- 1) Half elastic space theory based on previous research of Sung [10].
- 2) Compressor parameter method by Westergard [14].

III. ANALYSIS OF THE RESULTS

The first step in dynamic analysis of a correct modeling system is real system. In mathematics modeling, the equation of motion is formulated and then it can be solved by using a proper method. In previous chapter, the equation of fluid motion has been formulated. Here, structural equation of motion is achieved and the corresponding finite element equation as well as the range of fluid is provided.

A. Finite Element Modeling

In a system with Multi-Degree-Of-Freedom (MDOF), in order to define its motion at any point of time, it is necessary to know the amount of displacement in more than one point. A MDF system with “n” degrees of freedom that is accelerated in y-direction is shown in Fig. 2.

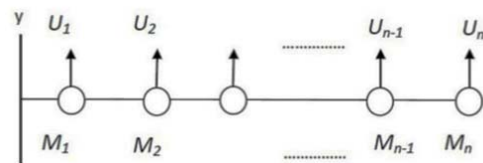

Fig. 2 A MDF system with DOF in y-direction

In a MDOF system, a system is separated into its degree of freedom (DOF). The numbers of freedom degrees is depended on the numbers of elements and freedom degree for each

element. Iso-parametric solid elements are usually used in liquid tanks. These kinds of elements are also used for two-dimensional issues in form of flat strain elements or flat tension.

Schematic configuration of a rectangular concrete tank that is more common in design codes is shown in Fig. 4. In this study, two configurations of different models related to shallow and depth tanks have been analyzed in both two and three-dimensional spaces. These tanks had also been used in some previous researches done by Kyanoosh and Chen, Sung and Kyanoosh and Chopra et al. [6], [10], [2]. Dimensions and

properties of shallow and deep tanks are as follows:

TABLE I
GEOMETRICAL AND MATERIAL PROPERTIES OF SHALLOW TANK

Pwkg/m ³	Ptkg/m ³	EGpa	V	Lx (m)	Lz (m)	Hw (m)	Ht (m)	Tw
2300	1000	26.44	0.17	15	30	6.0	5.5	0.6

TABLE II
GEOMETRICAL AND MATERIAL PROPERTIES OF DEEP TANK

Pwkg/m ³	Ptkg/m ³	EGpa	V	Lx (m)	Lz (m)	Hw (m)	Ht (m)	Tw
2300	1000	20.77	0.17	9.8	28	12.3	11.2	1.2

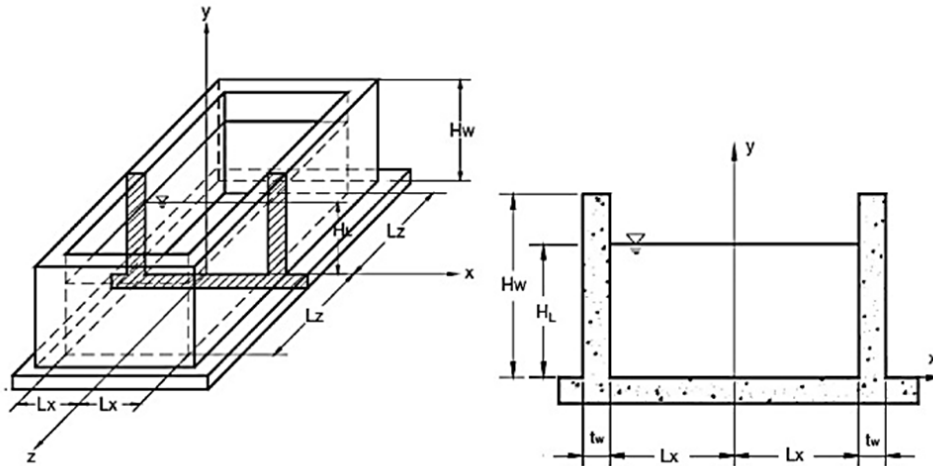

Fig. 3 A schematic of configuration of rectangular fluid reservoir

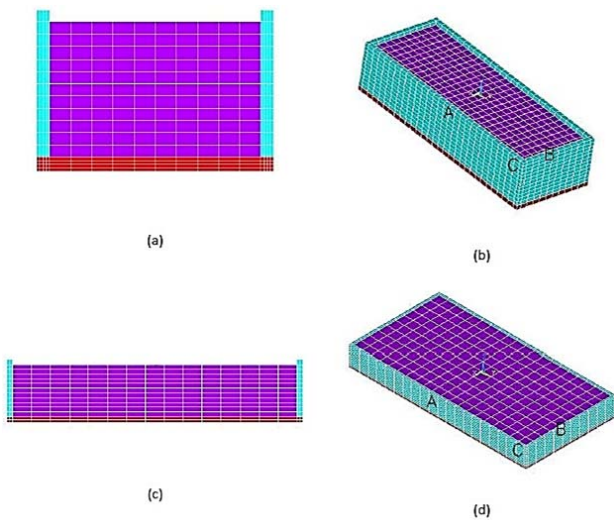

Fig. 4 Rectangular tank finite element model: (a) two-dimensional deep tank model (b) three-dimensional deep tank model (c) two-dimensional shallow tank model (d) three-dimensional shallow tank model

A one meter beam of reservoir in middle of longer dimension has been modeled for simulation of two-dimensional behavior of system. In the current design code, it

is generally assumed that reservoir is placed on rigid foundation base and the impacts of SSI is indirectly considered by using coefficients of position of Fa and Fv in accordance with ACI 350 [16]. It is also assumed that tank is controlled in the base and the effects of uplift pressure have not been considered.

Configurations of FE model for both shallow and deep tanks are shown in Figs. 4 A, B and C. Two-dimensional model includes 182 solid elements and 110 liquid elements for configuration of shallow tank and 149 solid elements and 165 liquid elements for configuration of deep tank. Longitudinal, transverse and vertical components recorded for El Centro earthquake (1940), are used as an initial excitations of reservoir system and liquid. These components are scaled in such a way that maximum acceleration of earth in longitudinal direction is 0.4 g, as is shown in Fig. 5.

Two model of concrete rectangular liquid tank are shown in Fig. 4, are essentially used for analyzing sample in time domain. In order to investigate the effect of three-dimensional geometry on dynamic behavior of liquid tanks, both responses of two and three-dimensional tank were obtained. Cross section has been taken parallel to the short side walls for two-dimensional FE models. It should be noted that longitudinal and transverse components of the earthquake that is perpendicular to the higher and lower tank wall, have simultaneously been applied in three-dimensional modeling

and are called horizontal excitation. In addition, both rigid boundary and flexible conditions have been applied for analyzing the effect of wall flexibility on seismic response of liquid tanks, including both impulsive and convective component.

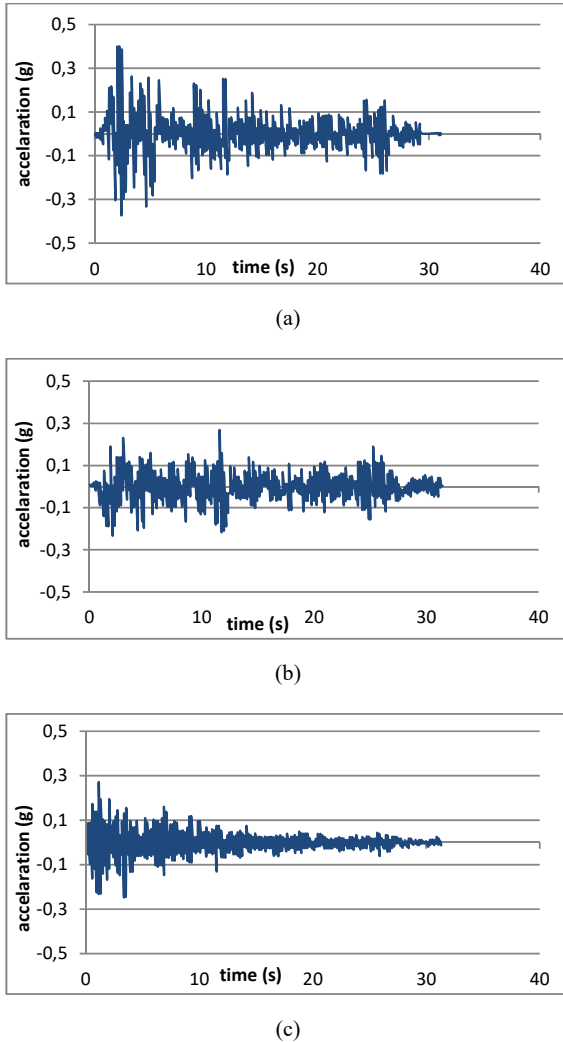

Fig. 5 Scaled components of El Centro earthquake in 1940: (a) longitudinal component (b) transverse component (c) vertical component

Finally, particular issues like SSI and the impact of earthquake frequency content will be considered by using appropriate boundary conditions and different earthquake records.

B. The Effect of Wall Flexibility on Dynamic Behavior of Liquid Tank Models

Two model of liquid rectangular concrete tank are essentially used for analyzing sample in two-dimensional space. Cross section is taken parallel to the short side walls for two-dimensional FE models which include both impulsive and convective responses. In order to investigate the flexibility

effect of wall on dynamic behavior of liquid tanks, both responses of flexible and rigid tanks have been achieved. Seismic analyses are done by using both horizontal and vertical components of ground acceleration and results will be compared with other related methods in the essays.

A comparison between FE, ACI code and analysis results has shown that the results of FE in terms of the amount of convection especially for shallow tank model are in agreement with amounts of ACI code. This is mainly due to the linear wave equation used in both methods. Nevertheless, some differences are found between impulsive expressions.

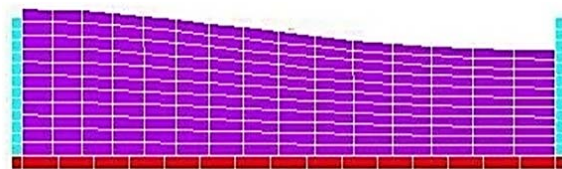

Fig. 6 The formation of the first main frequency from turbulence

C. The Response of Two-Dimensional Shallow Tank Model with Rigid Wall

When the ground accelerations are defined, time history analysis is done to calculate the response of structure in each of specified time steps in computer program. In this study, changes of impulsive and convective responses of structure with time are achieved to consider the time-dependent response characteristics of fluid-structure system. The related diagrams for base shear and base torsion are respectively shown in Figs. 7 and 8.

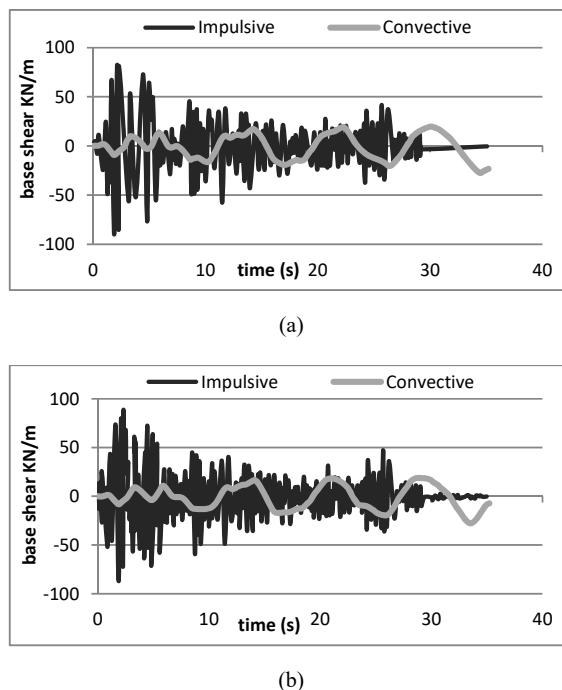
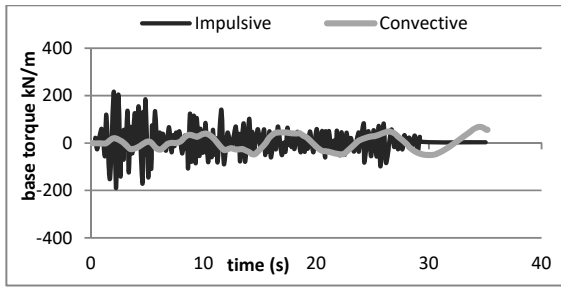
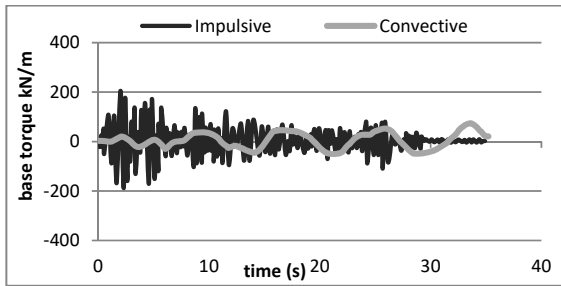

Fig. 7 Time history of base shear for shallow tank model with rigid side walls: (a) horizontal stimulation (b) horizontal and vertical stimulation



(a)



(b)

Fig. 8 Time history of base torsion for shallow tank model with rigid side walls: (a) horizontal stimulation (b) horizontal and vertical stimulation

Given to the combined effect of horizontal and vertical movements of the earth, the responses of base shear and impulsive base torque are reduced in a small amount by about 2 and 3%, while; the absolute maximum values of base shear and transient base torque for rigid shallow tank model and convective base torque are increased in a small amount sequent, 4 and 6%. It has been cleared that in this case, vertical acceleration of earthquake has little effect on seismic response.

D.The Response of Two-Dimensional Deep Tank Model with Rigid Wall

Figs. 9 and 10 show the structural response diagrams based on time history of base shear and base torque for rigid deep tank model. The absolute maximum amounts of base shear and base torque resulted from impulsive component, due to the horizontal stimulation, sequent are 328 kN/m and 1575 kNm/m. Given to the movement of freedom surface, the values of absolute maximum obtained from responses of base shear and convective base torque, respectively are 39 kN/m and 202 kNm/m, which occurred nearly 5 seconds after maximum impulsive responses. In this case, the values of absolute maximum of convective response are approximately 10% of related values with impulsive response. Nevertheless, this ratio is much higher in shallow reservoir model. As a result, the convection in shallow tanks is more important than deep tank.

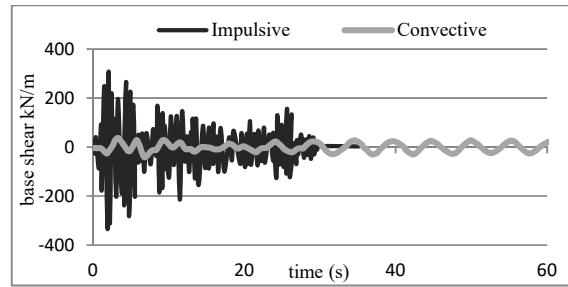

(a)

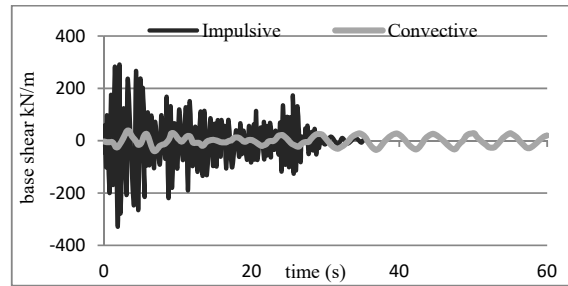

(b)

Fig. 9 Time history of base shear for deep tank model with rigid side walls: (a) horizontal stimulation (b) horizontal and vertical stimulation

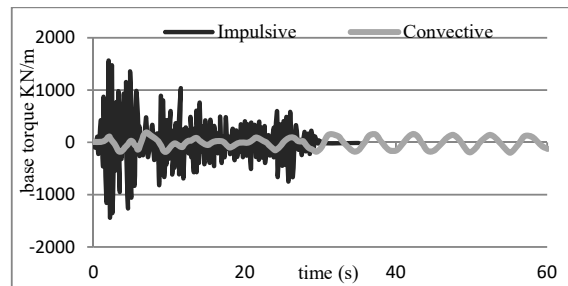

(a)

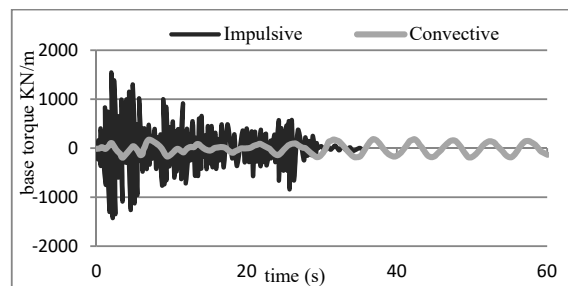

(b)

Fig. 10 Time history of base torque for deep tank model with rigid side walls: (a) horizontal stimulation (b) horizontal and vertical stimulation

Due to the effect of vertical movement of the earth, the impulsive response is reduced 1%, while convective response is approximately increased 4%, that it shows the same trend

with the trend observed in the shallow reservoir model. Furthermore, the ratio of the maximum height of the turbulence to fluid height ($\eta = \delta_{max}/HL$) is calculated for both shallow and deep tanks. Their corresponding values for shallow and deep tank models under horizontal stimulations respectively equal to 0.095 and 0.058. This shows that the impact of turbulence on fluid-tank system in shallow tank is more important than deep tank.

E. The Response of Two-Dimensional Shallow Tank Model with Flexible Wall

In order the effects of flexibility of tank wall on dynamic pressure distribution and dynamic respond of tank's structure to be concerned, a border condition of additional FE flexible wall has been analyzed in this study. Dynamic responses of shallow tank structure are provided in Fig. 11 in base shear and base torque form.

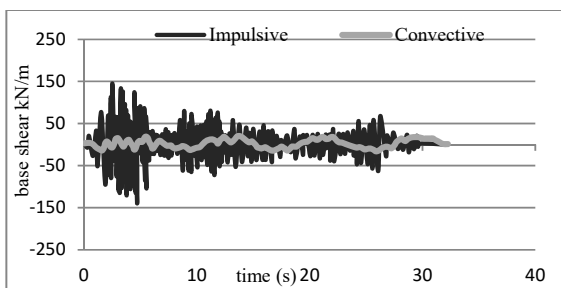

(a)

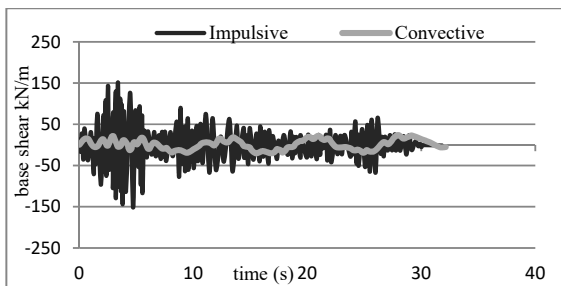

(b)

Fig. 11 Time history of base shear for shallow tank model with flexible side walls: (a) horizontal stimulation (b) horizontal and vertical stimulation

The absolute maximum of shear and torque respectively equal to 142 kN/m and 415 kNm/m. In comparison to results of rigid boundary conditions, the values of related maximum with base shear and impulsive base torques, because of flexibility of side walls, have significantly been increased by about 60 and 99%. Nevertheless, the effect of wall flexibility on convective response is fewer than its effect on impulsive responses, as presented in Table III.

Vertical component of earthquake has more effect on convective expression than impulsive expression. The maximum values of base shear and convective base torque have been increased about 9 and 13%, respectively. This

increase is nearly about 5% for impulsive expressions. Since the impulsive component is followed by total respond, it can be concluded that the effect of vertical acceleration on total response of liquid reservoir system is negligible.

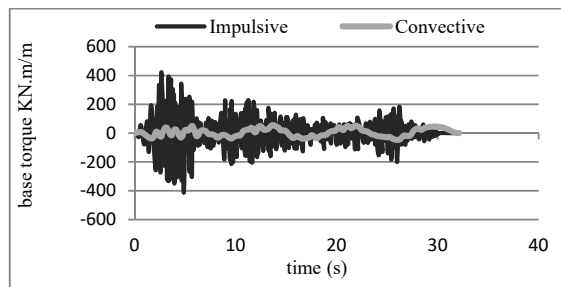

(a)

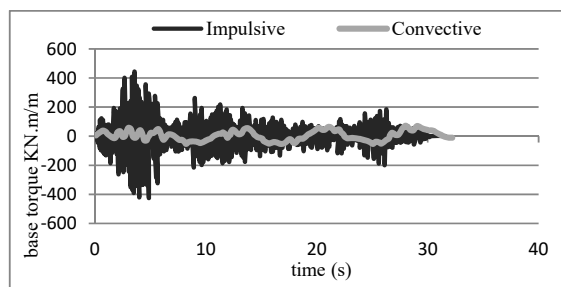

(b)

Fig. 12 Time history of base torque for shallow tank model with flexible side walls: (a) horizontal stimulation (b) horizontal and vertical stimulation

F. The Respond of Two-Dimensional Deep Tank Model with Flexible Wall

Fig. 13 shows the responses of structure in terms of time history of base shear and base torque for flexible deep tank model. Compared to rigid boundary conditions, the maximum absolute values of base shear and impulsive base torque resulting from horizontal component of earthquake have respectively been increased about 79 and 130% in amount of 588 kN/m and 3330 kN/m. It has been specified that the effect of flexibility on impulsive expressions in deep tank model is significant than shallow tank model.

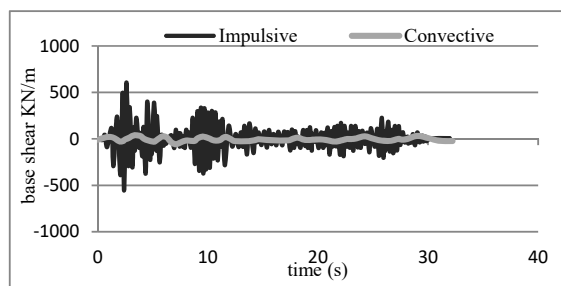

(a)

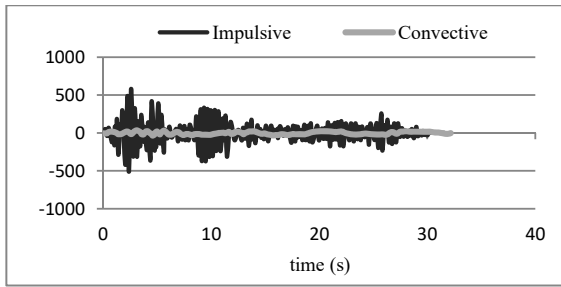

(b)

Fig. 13 Time history of base shear for shallow tank model with flexible side walls: (a) horizontal stimulation (b) horizontal and vertical stimulation

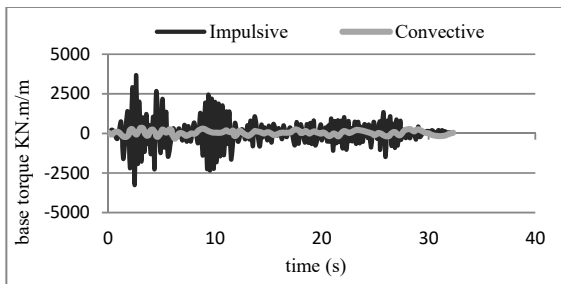

(a)

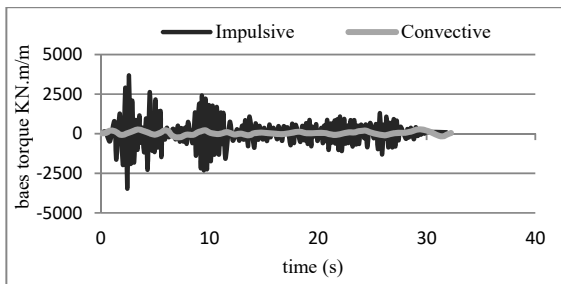

(b)

Fig. 14 Time history of base torque for shallow tank model with flexible side walls: (a) horizontal stimulation (b) horizontal and vertical stimulation

As shown in Figs. 13 and 14, convective expression may cause to increase or reduction of responses of structure. This phenomenon can be described as a phase difference between impulsive and convective responses that it depended on different parameters such as configuration of tank, earthquake frequency and border conditions of fluid and structure.

IV. DISCUSSION

In this study seismic convective and impulsive behavior of liquid reservoir models have been obtained, as it was previously discussed regarding to both rigid and flexible conditions and fluid damping properties. In analytical methods and approximation of the current outright mass, the absorbing boundary condition of impulsive wave and viscosity of the fluid are ignored. To verify the suggested FE method as well

as to consider the effect of fluid damping properties, two different statuses with zero and non-zero fluid damping ratios are used for rigid tank two-dimensional model and the obtained results are compared with analytical responses. These results have been provided in terms of impulsive hydrodynamic pressure on the tank's height.

According to the results, ignoring the damping of liquid, FE pressure distribution is in full agreement with the analytical results. For 5% damping ratio, impulsive pressure is reduced up to approximately 50% for both shallow and deep reservoirs model. This shows that fluid damping is an important parameter with regards to seismic behavior of liquid tanks. This fact has not directly been considered in current laws and standards that are based on combined mass models.

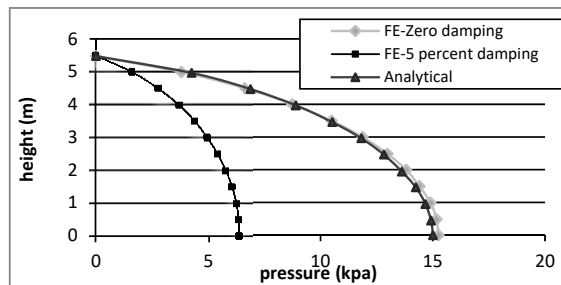

(a)

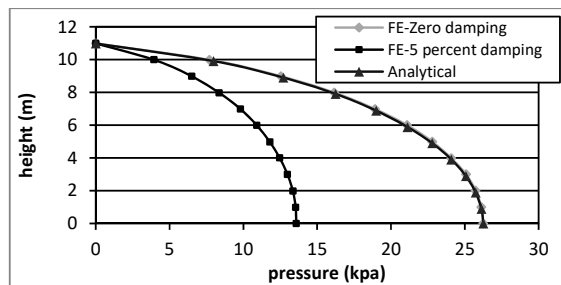

(b)

Fig. 15 Distribution of impulsive hydrodynamic pressure on the wall with rigid wall: (a) shallow tank (b) deep tank

Responses of base shear and base torque are very similar to the reported cases by Kianoush for shallow tank model under scaled components of El Centro earthquake with 0.4 g maximum acceleration [6].

A similar deep tank model was analyzed by Tait et al. using BEM-FEM under El Centro acceleration horizontal stimulation with 0.32 g maximum acceleration. The reported two-dimensional base shear response is nearly equal to the corresponding value in present study, but there is a significant difference about 50% among 3D responses [11]. Two-dimensional impulsive responses are also comparable with obtained cases by Yang's study, by using a chain method under horizontal component of El Centro earthquake with 0.32 g maximum acceleration for both shallow and deep tanks [15]. In their chain method, the flexibility of wall has been considered. Nevertheless, the impulsive behavior of tank is

only been considered and convective component is ignored. In their study, maximum of base shear and impulsive base torques for shallow tank model is equal to 78.7 kN/m and 241.8 kNm/m while maximum of impulsive base shear for deep tank model is equal to 338.1 kNm/m. These amounts are much lower than the proposed FE results.

TABLE III
TWO-DIMENSIONAL STRUCTURAL RESPONSES BASED ON HASNER METHOD
USED IN ACI 350.3-06 FOR BOUNDARY CONDITIONS OF RIGID WALL

	Base shear (kN/m)				Base torsion (kN.m/m)			
	ACI		FE		ACI		FE	
	V_i	V_c	V_i	V_c	M_i	M_c	M_i	M_c
Shallow tank	171	20	89	25	463	56	209	67
Deep tank	625	43	328	39	4063	281	1575	202

According to Hasner method for shallow tank model under horizontal stimulations, the base shear and impulsive base torques are equal to 171 kN/m and 463 kNm/m, while for deep tank model, the base shear and impulsive base torques are equal to 625 kN/m and 4063 kNm/m. These values are approximately 100% higher than the obtained values by using FE method for rigid tank models. Nevertheless, in terms of base shear and turbulence height of the rigid wall boundary conditions, FE convective response is in satisfactory agreement with the Hasner model. For example, convective base shear calculated by Hasner method for deep tank model under horizontal movement of earth is equal to 43 kN/m, which is only 10% greater than the value obtained by using FE method. For this case, turbulence height based on Hasner model is equal to 710 mm that is approximately 12% greater than the amount calculated by FE method. It is clear that the calculated maximum responses of structure in three-dimensional models for all cases, is greater than calculated values by spectrum analysis and two-dimensional models. As a result, three-dimensional geometry plays an important role in dynamic behavior of rectangular liquid tank and it magnifies the responses of structure. It should be mentioned that spectrum analysis method that is commonly used in design laws is based on a two-dimensional tank model and it ignores the effect of three-dimensional geometry. This effect is needed to be more analyzed in laws and standards of design.

Finally, the results of FE analysis in current method are compared with experimental results of seismic desk tests a three-dimensional rectangular tank model constructed from acrylic plates, that was done by Mcverry in order to confirm the accuracy of three-dimensional modeling of turbulence behavior [7].

In their study, the viscous damping ratio is about 5 percent from conducted initial test with an empty tank model. Six barometers, two dozen accelerometers and two water level gauge are placed to measure dynamic responses of tanks. Nevertheless, in the last part of the time history results a significant difference can be realized. These abnormalities can be justified as a result of increasing of energy dissipation during the test that causes to change the properties of fluid

damping.

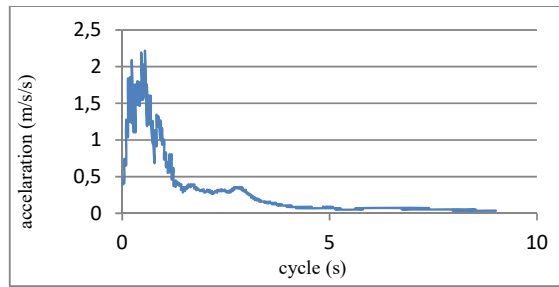

(a)

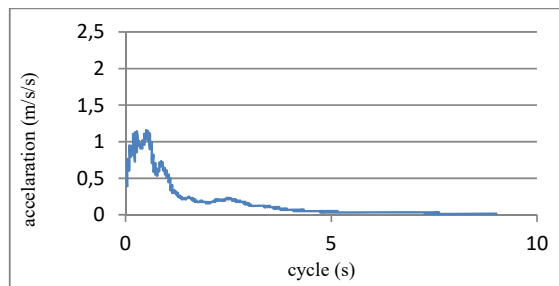

(b)

Fig. 16 Response spectrum of El Centro earthquake in 1940 in longitudinal direction: (a) 0.5% damping (convective) (b) 5% damping (impulsive)

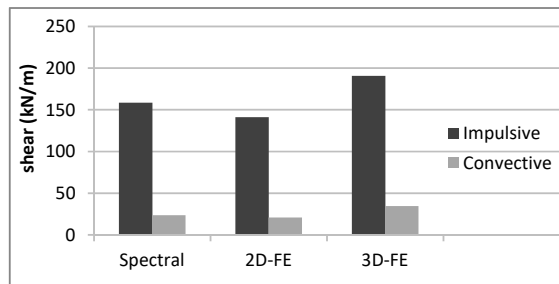

(a)

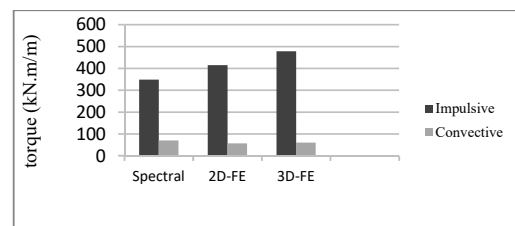

(b)

Fig. 17 Impulsive and convective structural responses: (a) base shear (shallow tank) (b) base torque (shallow tank)

V. CONCLUSION

In this part, dynamic behavior of rectangular fluid tanks partially filled under horizontal and vertical stimulations of the earth has been analyzed by using FEM in both two and three-

dimensional spaces. Fluid's turbulence has been modeled by using an appropriate boundary condition and damping effects due to the impulsive and convective components of stored liquid has been modeled by using railing method. In order to investigate the effect of geometry on response of liquid and structure system, two different configurations include shallow and deep tank models have been considered. In this chapter, the effect of flexibility of wall on total dynamic response of system has been analyzed by comparison the results between rigid and flexible two-dimensional models. In second part, in order to investigate the effect of three-dimensional geometry on dynamic behavior of liquid tanks, a comparison has been done between responses of two and three-dimensional tank model. In addition, the effect of vertical movement of the earth on seismic responses of liquid tank models has been discussed.

The results show that base shear and maximum impulsive base torque obtained from analysis of time history of considered system have been increased for flexibility of side walls that is a result of increasing dynamic pressure in middle of wall. Nevertheless, convective response is almost independent from flexibility changes of side walls and it seems that is related to geometric configurations of tank, earthquake properties and liquid features. A few changes have been seen in amounts of convective pressure compared to amount of impulsive pressure due to the flexibility of wall. Although, the current methods assume that numerical amount of convective pressure reached to zero in the bottom of the tank, the suggested FE method shows different results. Furthermore, maximum responses of impulsive and convective components do not occurred in the same phase and time. Consequently, convective expressions may cause to increase or to reduce the absolute maximum values of structural responses in terms of base shear and base torque. As well as, by applying vertical stimulation the convective response of system will be increased. Nevertheless, impulsive behavior is not significantly affected by it. This increase is more remarkable in deep reservoir model. This point is valid for both two-dimensional and three-dimensional reservoir model.

Although, convective responses of two-dimensional finite element are in satisfactory agreement with obtained corresponding responses using Hasner method for rigid tank model, seismic-impulsive response of liquid tanks, and accordance with the Hasner method that is currently used in current laws and standard, seems too conservative in terms of shear forces and torsion.

It is obvious that dynamic behavior of liquid concrete tanks are depended on wide range of parameters such as seismic properties of earthquake, tank dimensions and liquid-structure interaction that must be considered in future researches. This study shows that suggested FE method can be used in analyzing time history of rectangular liquid tanks. One of the main advantages of this method is to calculate the flexibility of wall, the effects of three-dimensional geometry, damping properties of liquid domain and to compute separately the impulsive and convective components. As well as, this

involves applying different damping ratios to different impulsive and convective components and attention to flexibility of wall that has an important role in seismic response. Nevertheless, this method is not able to stimulate accurately non-linear behavior of turbulence in liquid tanks.

REFERENCES

- [1] ANSYS Inc. ANSYS help manual Version 11.1, (2004). Global headquarters, Southpointe, 275 Technology drive, Canonsburg, PA 15317.
- [2] Chopra, A.K. (1995). Dynamics of structures. Prentice-Hall. Upper Saddle River, N.J.
- [3] Ghaemian, M. and Ghobarah, A. (1997). Nonlinear seismic response of concrete gravity dams with dam-reservoir interaction. *Journal of engineering structures*, 21(4): 306-315.
- [4] Ghaemmaghami, A.R. and Kianoush, M.R. (2009). Effect of wall flexibility on dynamic response of concrete rectangular tanks under horizontal and vertical ground motions. *ASCE Journal of Structural Engineering*, Accepted for publication.
- [5] Haroun, M.A., and Tayel, M.A. (1985). Response of tanks to vertical seismic excitations. *Earthquake Engineering and Structural Dynamics*, 13: 583-595.
- [6] Kianoush, M.R., and Chen, J.Z. (2006). Effect of vertical acceleration on response of concrete rectangular liquid storage tanks. *Engineering Structures*, 28(5): 704-715.
- [7] Mcverry, G.H., (1979). Frequency domain identifications of structural models from earthquake records. Report No. EERL 79-02, California Institute of Technology.
- [8] Mirzabozorg, H., Khaloo, A.R., and Ghaemian, M. (2003). Staggered solution scheme for three dimensional analysis of dam reservoir interaction. *Dam Engineering*, 14(3): 147-179.
- [9] Rashed, A.A., and Iwan W.D., (1984). Hydrodynamic pressure on short-length gravity dams. *ASCE Journal of Engineering Mechanics*, 110(9): 1264-1283.
- [10] Sung, T.Y., (1953). Vibrations in semi-infinite solids due to periodic surface loading. *ASTM STP*, 156: 35-68.
- [11] Tait, M.J., El Damatty, A.A., Isyumov N. and Siddique M.R., (2005). Numerical flow models to simulate tuned liquid dampers (TLD) with slat screens. *Journal of Fluids and Structures*, 20(8): 1007-1023.
- [12] Veletsos, A.S., and Tang, Y. (1986). Dynamics of vertically excited liquid storage tanks. *ASCE Journal of Structural Engineering*, 112(6): 1228-1246.
- [13] Veletsos, A.S., and Yang, J.Y. (1977). Earthquake response of liquid storage tanks-advances in civil engineering through mechanics. *ASCE Proceedings of the second engineering mechanics specially conference*, Raleigh, NC: 1-24.
- [14] Westergaard, H.M. (1938). Water pressure on dams during earthquakes. *Transaction, American society of civil engineers*, 98: 418-433.
- [15] Yang, J.Y. (1976). Dynamic behavior of fluid-tank systems. Ph.D. thesis, Department of Civil Engineering, Rice.
- [16] ACI 350, (2006). Code Requirements for Environmental Engineering Concrete Structures and Commentary, an ACI Standard, USA.