

Automated Buffer Box Assembly Cell Concept for the Canadian Used Fuel Packing Plant

Dimitrie Marinceu, Alan Murchison

Abstract—The Canadian Used Fuel Container (UFC) is a mid-size hemispherical headed copper coated steel container measuring 2.5 meters in length and 0.5 meters in diameter containing 48 used fuel bundles. The contained used fuel produces significant gamma radiation requiring automated assembly processes to complete the assembly. The design throughput of 2,500 UFCs per year places constraints on equipment and hot cell design for repeatability, speed of processing, robustness and recovery from upset conditions. After UFC assembly, the UFC is inserted into a Buffer Box (BB). The BB is made from adequately pre-shaped blocks (lower and upper block) and Highly Compacted Bentonite (HCB) material. The blocks are practically ‘sandwiching’ the UFC between them after assembly. This paper identifies one possible approach for the BB automatic assembly cell and processes. Automation of the BB assembly will have a significant positive impact on nuclear safety, quality, productivity, and reliability.

Keywords—Used fuel packing plant, automatic assembly cell, used fuel container, buffer box, deep geological repository.

I. INTRODUCTION

THE Nuclear Waste Management Organization (NWMO) is implementing Adaptive Phased Management (APM), the approach selected by the Government of Canada for the long-term management of Canada’s used nuclear fuel [1]. The goal of APM is the development of a Deep Geological Repository (DGR), constructed in a suitable rock formation in either sedimentary or crystalline rock. The repository design concept is based on a multiple-barrier system that incorporates engineered and natural barriers to contain and isolate used nuclear fuel (see Fig. 1). The implementation of APM is based on safety, technical excellence, and social acceptability. An objective of the APM Engineering Program is to develop preliminary designs and cost estimates for the DGR. This includes the design of robotic equipment to transfer and package used nuclear fuel at the UFPP surface facility at the DGR site.

As of July 2017, approximately 2.8 million used Canadian Deuterium Uranium (CANDU) fuel bundles were in storage at Canadian reactor sites. Used nuclear fuel is currently stored in wet bays or in dry storages located at the reactor sites. Used nuclear fuel will be delivered in suitable transportation casks to the DGR site, where it will be repacked into corrosion-resistant, long-lived containers, and then transferred

underground to be placed in the repository. The UFPP, which will be part of the DGR surface facilities (Fig. 1) [2], is designed to receive used nuclear fuel in the transportation casks and transfer it to the long-lived UFCs. The UFC is sealed, inspected, and placed into a Buffer Box (BB) for transport to the underground repository with the help of shielded carts. The UFPP is designed to process 120,000 CANDU used fuel bundles per year over its 40-year lifetime. This is high throughput for a nuclear facility. Nuclear fuel removed from a reactor core is highly radioactive and must be handled in environments that provide both shielding and containment. As such, areas designed for the handling of used fuel are normally not accessible to operators, and remote-controlled equipment is required for fuel-handling operations.

In the case of the UFPP, the fuel received at the plant will be packed under dry conditions into UFCs. Fuel handling operations including loading and sealing of the UFCs, BB assembly will be performed within a containment volume, which provides shielding for the safety of UFPP personnel.

Another requirement for the UFPP systems design is redundancy. Operators must be able to recover from upset conditions and continue the fuel packing operations using redundant equipment. Remote handling processes and equipment are required for this purpose. Historically, remote manipulators have been used in such environments. Provisions for recovery from upset conditions place unique design constraints for the plant processes automation [5].

A manipulator has similar features to those of a robot, but it is normally under the direct control of an operator, usually in the form of manual remote control.

II. RADIATION LEVELS IN THE UFPP BB ASSEMBLY CELL AND CONSEQUENCES

In [3], some aspects related to radiation level influence on the robotic or automated equipment used in the UFPP were mentioned.

Since the UFC has thinner walls than its predecessors, the radiation level in the cell can be relatively high (max. gamma of 543 mSv/h at 1 m from the UFC surface –in UFC radial direction [4]).

Special radiation protection measures are suggested to be taken in the cell. For example [3]:

- Replacing or elimination of plastic or rubber materials in the cell’s construction;
- Radiation-hardened electrical motors and encoders;
- Minimum IP67 qualification for all actuators;
- Motor and encoder redundancy;
- Manipulator motor override possibility;

Dimitrie Marinceu (Dr) is with the Nuclear Waste Management Organization, Toronto, ON, M4T2S3, Canada (phone: 647-259-3711, e-mail: dmarinceu@nwmo.ca).

Alan Murchison is with the Nuclear Waste Management Organization, Toronto, ON, M4T2S3, Canada (phone: 647-259-3713, e-mail: amurchison@nwmo.ca).

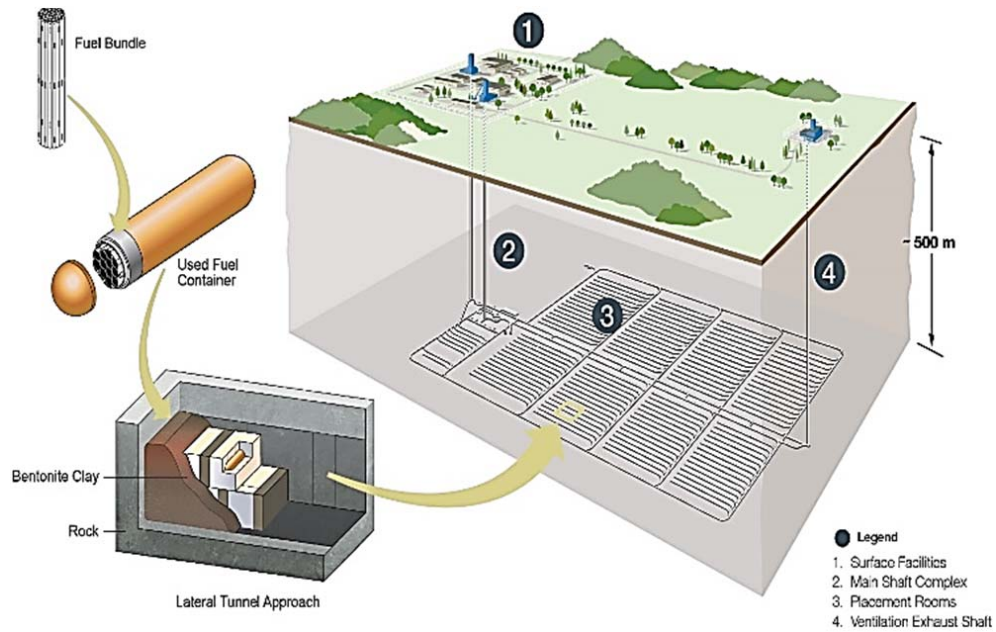

Fig. 1 APM Deep Geological Repository

- Manipulator-friendly fasteners and surfaces for the robot’s components, for recovery and maintenance;
- Simple assembly, disassembly and maintenance procedures that can be accomplished by remote manipulators;
- Main components and subassemblies sized to fit into UFPP low-level waste container for easy disposal;
- Accessible lift points for crane lifting;
- Radiation-resistant cables and hoses; and:
- Washable components for ease of decontamination.

Due to the radiological hazard, human presence in the cell is controlled and limited. Manipulators will be used for maintenance, repairs, recovery from upset conditions within the assembly cell.

III. SOME MAIN ACTORS IN THE BB ASSEMBLY CELL

For this concept, the following main items are intended to be used (their design is in different stages of evolution):

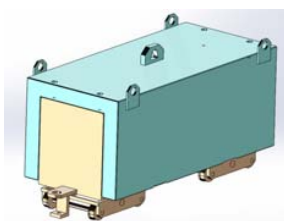

Fig. 2 BB Shielded Cart

- a) A cart on rails, which contains at entering the cell- the lower BB, and after assembly, the completed BB (with UFC inside) as shown in Fig. 2. The shielding can be removed before BB assembly, and reinstalled and secured after BB completion. Redundancy is provided.

- b) Automated Guided Vehicle (AGV) for the upper BB. It contains the upper BB already oriented for assembly (see Fig. 3).

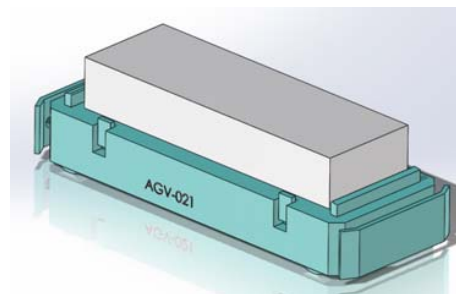

Fig. 3-AGV for Upper BB

- c) Shielded AGV for the UFC. Its shielding can be opened automatically, or via manipulators –for redundancy (see Figs. 4 and 5).

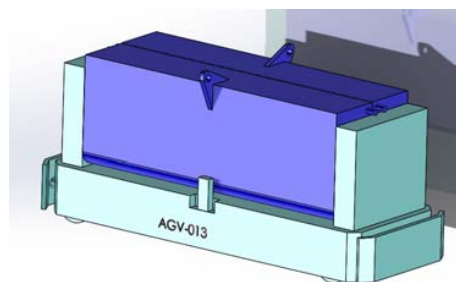

Fig. 4 AGV for UFC (closed)

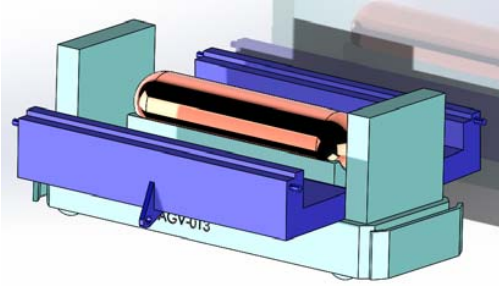

Fig. 5 AGV for UFC (open)

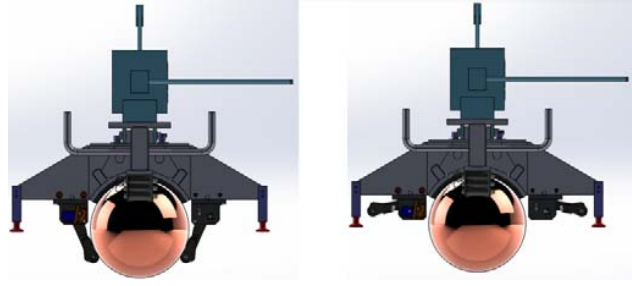

Fig. 7 UFC Vacuum Lifter –Safety Fingers Explanation

d) Vacuum UFC lifter, with retractable safety fingers (see Figs. 6 and 7). Fig. 7 explains the safety fingers operation mode.

e) Vacuum BB Lifter (see Fig. 8).

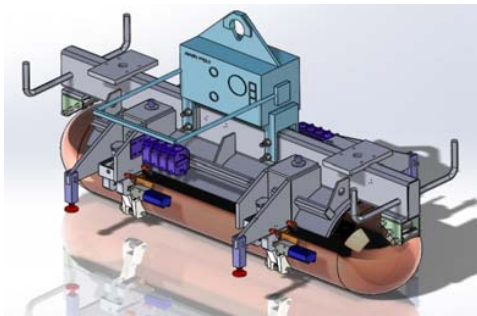

Fig. 6 Vacuum Lifter for UFC (safety fingers active)

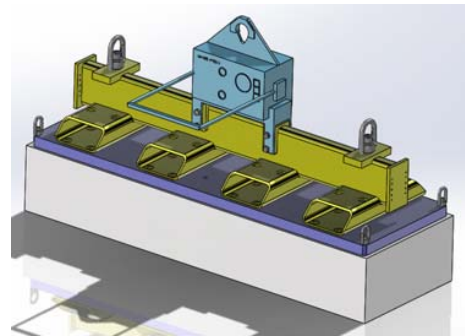

Fig. 8 Vacuum BB Lifter

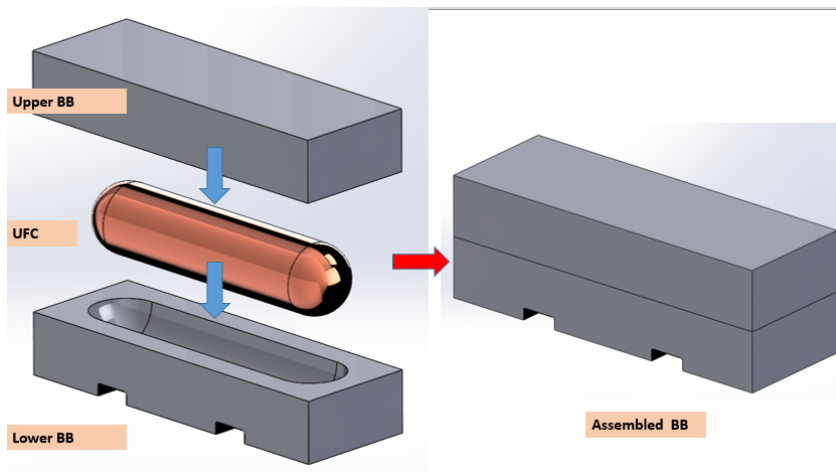

Fig. 9 Graphical Explanation of the BB Assembly

IV. BUFFER BOX ASSEMBLY BRIEF EXPLANATION

In the BB assembly cell, the following basic main operations shall be done:

- a) UFC insertion into the lower BB; and
- b) Upper BB installation over the UFC already contained in the lower BB.

Fig. 9 shows these essential operations for the BB assembly.

In order to achieve this simplicity for the BB assembly,

many researches and experiments were done, in order to have shaped HCB buffer boxes with consistent strength and geometry.

V. BB ASSEMBLY CELL LAYOUT

The cell layout is shown in Figs. 10-13.

The cell has two main compartments:

- a) A shielded main cell for operations (the cell is provided with gantries A and B)

b) A shielded smaller cell, for cart shielding temporary removal (the cell provided with gantry C) as shown in Fig. 10.

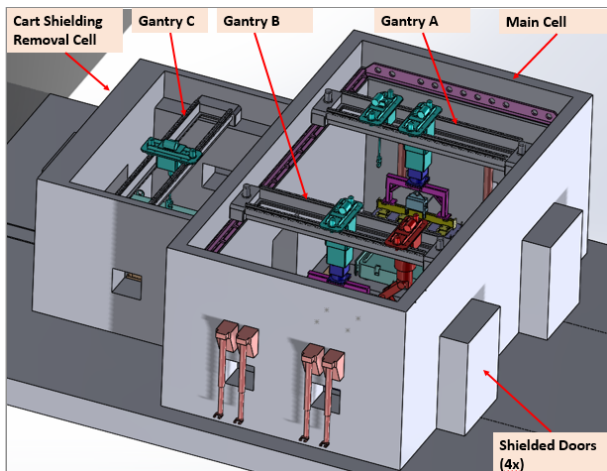

Fig. 10 ISO View of BB Assembly Cell

The gantry A is dedicated for upper BB vacuum lifting and some additional operational lifting.

The gantry B is dedicated for UFC vacuum lifting and for some possible disturbance handling –via the installed remotely operated mobile tele-manipulator (see Figs. 11 and 12).

The gantry C is dedicated for redundant cart shielding lifting. The cart shielding is normally lifted by a jack system (see Fig. 13).

The cart can be moved into the main cell via a cart push-pull system- provided with redundancy.

Operator presence in the cells is limited and permitted only if radiation shielding is completely assured.

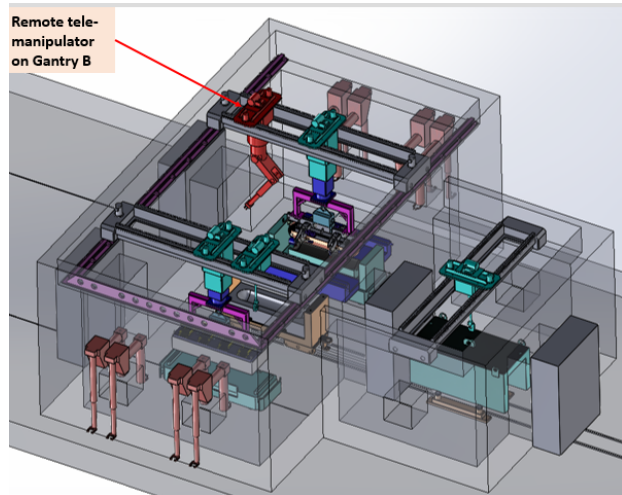

Fig. 11 ISO View 2 –BB Assembly Cell with Transparent Walls

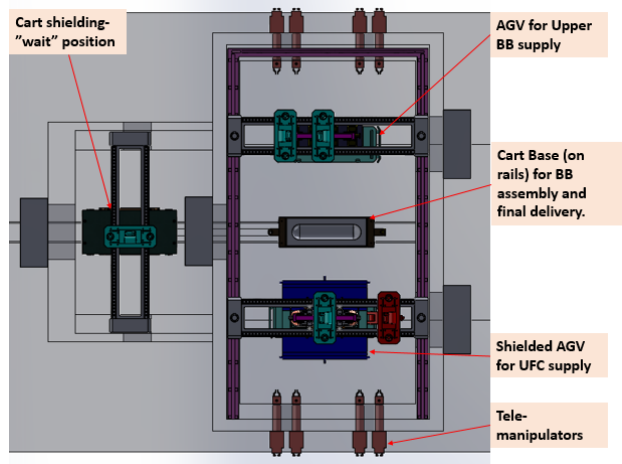

Fig. 12 Top View- BB Assembly Cell

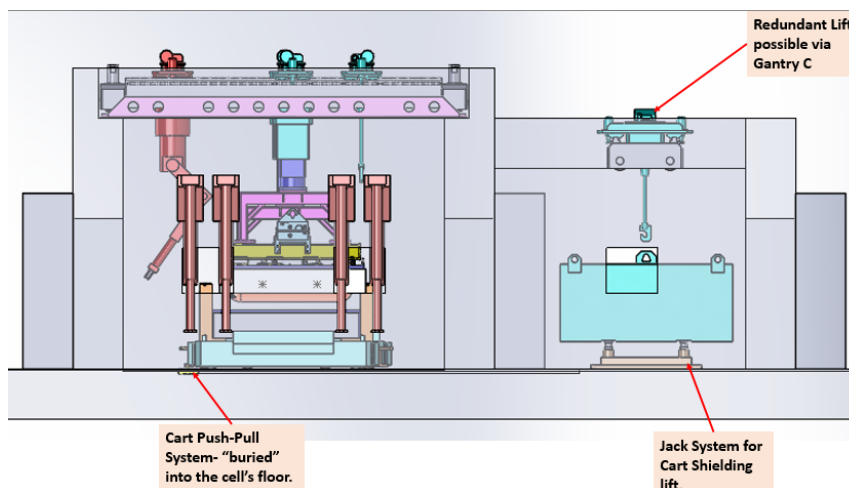

Fig. 13 Side View- BB Assembly Cell Transparent Walls

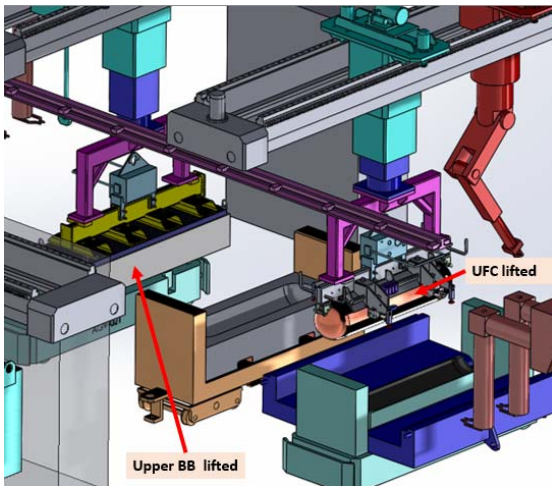

Fig. 14 Assembly Cell Detail View –Showing UFC and Upper BB Lifting (cell floor & walls are hidden)

VI. SUMMARY OF OPERATIONS IN THE BB ASSEMBLY CELL

The performed main operations for the BB assembly are:

- The shielded cart with the bottom BB already in, enters the shielding removal cell;
- The push pull mechanism is connected;
- The cart's shielding is lifted by jacks;
- The cart enters the main cell via push-pull mechanism, and is locked in assembly position;
- The AGV with the upper BB enters the main cell and is locked in position;
- The AGV with the UFC enters the main cell and is locked in position;
- All shielding doors are closed (no operators anymore in the cell);
- The AGV with the UFC opens its shielding;
- The UFC is picked up by the vacuum lifter from gantry B (safety fingers will be for 98% of time "on");
- The UFC is transported and inserted into the lower BB from the cart;
- The upper BB is picked up by the vacuum lifter from gantry A;
- The upper BB is transported and inserted over the UFC and lower BB;
- The shielding door between the shielding removal cell and the main cell is opened;
- The cart with the assembled BB leaves the main cell and enters the shielding removal cell;
- The shielding door between the shielding removal cell and the main cell is closed;
- The cart shielding is lowered over the cart with BB;
- The shielding is secured remotely;
- The shielding doors are open for eventual operator access, but not before making sure (via sensors) that all cells are radiation safe;
- The cart with shielding "on" and BB inside exits the shielding removal cell (with the destination DGR);
- The AGV for the UFC closes its shielding and exits the

main cell; and:

- The AGV for the upper BB exits the main cell.

Fig. 14 shows the UFC and the upper BB lifting. The cell's walls are hidden for clarity.

VII. CONCLUSIONS

In the BB Assembly Cell, incorporating appropriate shielding strategies, safe automatic work processes can be implemented. The automated equipment will be provided with special features [3]. Remote manipulators are incorporated in the design, to provide the required redundancy for recovery from process upsets. Simplified automation will provide a significant positive impact on nuclear safety, quality, productivity, and reliability.

REFERENCES

- [1] Nuclear Waste Management Organization. 2005. Choosing A Way Forward: The Future Management of Canada's Used Nuclear Fuel – Final Study. Issued by NWMO to the Minister of Natural Resources Canada in November 2005, Toronto, Canada.
- [2] SNC Lavalin "Deep Geological Repository Design Report, Crystalline Rock Environment", 0206-06-6100-REPT-0001, Toronto, Canada.
- [3] D. Marinceu, A. Murchison, C. Hatton – "Robots Usage into a Canadian Used Nuclear Fuel Plant", CARPI 2012, Zurich.
- [4] C. Medri, Internal document: "Scoping Estimates of UFC Shielding Thickness Requirements", APM-CALC-04330, NWMO, April 2012.
- [5] Z. G. Keszthelyi, D. Morikawa - "The CANDU 9 Fuel Transfer System", First Conference on CANDU Fuel Handling Systems", May 1996, Toronto.